

Industrial Applications of Radiation Technology and Radioisotopes

Pradip Mukherjee, Vinay Bhawe and Tarveen Karir

Board of Radiation & Isotope Technology (BRIT)

BARC-Vashi Complex,

Navi Mumbai 400703, India

Email: chief@britatom.gov.in

Preamble

'Isotopes' of an element are the atoms of the same element but with different number of neutrons in their nuclei. Though, the number of protons remain identical, the different neutron numbers in their nuclei affect the nuclear properties. Due to different combinations of neutrons and protons, some of the isotopes possess unstable nuclei. Usually, upto mass number 40, it is observed that proton/neutron (N/P) ratio remains as 1, and then slowly starts increasing. With increase in mass number, Coulombic repulsion due to protons increases and this leads to destabilization. Uranium is the last naturally occurring element and beyond $A=209$, there is no stable nuclide. Some isotopes have been artificially produced, either by bombarding the atoms with neutrons in a nuclear reactor, or with charged particles in an accelerator. Instability of a nuclide results in radioactive decay, also known as disintegration, (within the nuclei), and attain stability, resulting in the emission of particles and electromagnetic radiation, and hence they are named radioisotopes.

Radiations that are emitted by different radioisotopes can be used in a range of measurement systems for various applications, such as agriculture, cancer treatment, medical diagnosis, sterilization of medical products, radiation processing of spices, onion, etc., quality control in industries, non-destructive testing and processing of polymeric materials. The constant pursuit for new technologies in the atomic era has contributed meaningfully

towards the economic as well as societal benefits. India is among the very few early entrant nations in the world in the field of atomic sciences, possessing advanced facilities and knowledge for the production of a range of radioisotopes, radioisotopes-based medical and engineering products & associated equipment for value addition. This was due to the great visionary, Dr. Homi Jehangir Bhabha. Board of Radiation & Isotope Technology (BRIT) is the industrial unit of the Department of Atomic Energy (DAE) and is focused on bringing the benefits of the use of radioisotopes and radiation technology across the industry, healthcare, research and agricultural sectors of the society and serve the nation.

Introduction

The search of new tools and developing new techniques has been the reason behind advancement of mankind. Discoveries, such as radioactivity and X-rays were new tools for applications in industry. The first controlled nuclear fission chain reaction had been demonstrated by Enrico Fermi on December 02, 1942. This can be considered as the beginning of using the nuclear fission reaction to produce energy in a nuclear reactor. As a spinoff of the nuclear reactors, commercial use of radioisotopes became viable by enabling production of artificial radioisotopes.

The last few decades have witnessed use of radiation technology for peaceful development and social benefits. Radioisotopes and radiation technologies support most nuclear applications and contribute in many ways to healthcare, food safety and industrial development worldwide. Radioisotopes and radiation technologies also provide economically viable strategies for sterilization of medical products, cancer treatment, disease diagnosis therapy, waste-water treatment, gamma scanning for industrial radiography and tomography, tracer techniques, food preservation, development of high-yielding crop seeds and other similar areas.

The programme of the Department of Atomic Energy, right from the early stage, gave a lot of importance to this aspect and, as a result of that, significant advancement has taken place in the areas of radioisotope applications and radiation technology in the fields of medicine, industry, agriculture and research. The pioneering R&D work in BARC has helped to attain a high degree of self-reliance in the development of a variety of radioisotope related products and services, which has laid a firm foundation for utilization of radioisotope techniques and radiation technology in the country. In order to focus this activity in a more concrete way and for commercial utilization of some of the results of R&D, the Board of Radiation & Isotope Technology (BRIT) was engraved out of Bhabha Atomic Research Centre, as an independent industrial constituent unit of Department of Atomic Energy, on March 01, 1989.

In this chapter, an attempt is made to highlight the sources of radioisotopes and some of the important industrial applications of radioisotopes, including the infrastructures built at BRIT, over three and half decades, to cater to the customers with the related products, services and equipment.

Production Sources of Radioisotopes

Nuclear reactors are the primary source for large-scale production of neutron-rich radioisotopes by utilizing available excess neutrons produced during nuclear fission reaction. Few important neutron-rich radioisotopes are separated from fission products obtained from the spent fuel. Proton rich radioisotopes are produced by using particle accelerators. Cyclotrons are used in several countries, including India, for production of certain medical radioisotopes, e.g., ^{201}Tl , ^{18}F , ^{67}Ga , ^{68}Ge , etc.

In India, radiation and isotope programme took a concrete shape after the commissioning of APSARA reactor at Trombay in August 1956, under the Isotope Programme of BARC. The availability of APSARA reactor made India one of the very few countries at that time to produce radioisotopes locally, as well as nurture the development of their applications. The programme expanded in volume, when in 1963, the CIRUS reactor attained its rated capacity of 40 MWt, augmenting the production capability. The field of radiation technology was also rapidly growing through 1970's and BARC kept pace with most of the relevant developments in radiochemical, radiation sources, radiation processing using gamma sources, radiography cameras, radiopharmaceuticals, etc. A major increase in the production capacity of radioisotopes was observed when the 100 MWt reactor, Dhruva, had attained criticality in 1985. Dhruva is one of the large research reactors in the world and caters to the production of a wide spectrum of radioisotopes for use in medicine, industry, agriculture and research. All these reactors are located at Bhabha Atomic Research Centre (BARC), Trombay, and have ably supported the domestic production capabilities for radioisotope-based products and associated technologies and services to end-users. APSARA (U) launch, in recent years, is another supplementary source. Cobalt-60, an isotope that is used for several industrial and medical applications, including radiation processing, is produced in the power reactors operated by Nuclear Power Corporation of India Ltd. (NPCIL) and recovery *cum* processing facility (RAPPCOF) of BRIT is located at RAPS, Rawatbhata, Rajasthan. DAE/BRIT, India, is one of the very few sources in the world having the large-scale ^{60}Co production – supply capacity and technology capabilities.

The facilities, need to be well-equipped with hot-cells for handling and processing large quantities of radioactivity. BRIT operates processing facilities for radioisotopes. The hot-cell facilities at the Radiological laboratories and at the High Intensity Radiation Utilization Project (HIRUP) were established at BARC, Trombay, during 1973-74; and at the Rajasthan Atomic Power Plant Cobalt-60 Facility at Kota, Rajasthan (RAPPCOF) in the year 1975. The facility at RAPPCOF is augmented with the growing demand for the radioisotopes. These are used for processing the irradiated Cobalt-60 (from the Nuclear Power Plant) and for fabrication of the radiation sources. These processing facilities are as per the designs approved by regulatory agencies. Recently, ^{137}Cs radioisotope has also become commercially available, after successfully processing the spent fuel, isolating it from other fission products and formulating a safe glass vitrification technique.

Production of radioisotopes is challenging in terms of preparing them with the appropriate specific activity and radionuclide purity, while conforming to the specifications, for varied applications for which they are used. For example, the low specific activity (~ 60 Ci/g) Cobalt-60 would suffice for radiation processing applications, whereas very high specific activity (>250 Ci/g), is needed for teletherapy applications. In order to achieve high specific activity radionuclides, the irradiation conditions need to be appropriately adjusted, e.g., high flux reactors, irradiation position in suitable reactors, etc.

Ionizing Radiation, Radioisotope Sources and Radiation Technology for Industry

Ionising radiation are defined as radiation with adequate energy which can ionise/excite atoms in the interacting matter. This includes both electromagnetic radiation such as γ -rays and X-rays, and energetic particles such as α - and β -particles, and neutrons, which although may not be directly ionising, but are capable to produce secondary ionising radiation. Ionising radiation is often named after the origin of the radiation. *Nuclear radiation* may be defined as the radiation emitted by an unstable nucleus in an element, a *radioisotope*, which disintegrates to become stable.

The use of radioisotopes and radiation technology in industrial applications spans over a wide range. There are three different basic modes of applications of radioisotopes, based on the varied properties of radiation. The first category depends on the fact that the radiation affects the material, as in the case of radiation processing (Physical or chemical changes are induced in the target material by deposition of radiation energy). This property is used in radiation therapy of cancer, sterilization of medical products, food irradiation and in cross-linking of polymers. Second category is the applications of radioisotopes which utilizes the effects of radiation on materials leading to assessment of qualitative and quantitative properties of materials, as in the case of non-destructive testing, which is based on attenuation of radiation (mainly due to its absorption and scattering. The extent of attenuation depends on the composition and geometry of the object as well as energy and type of radiation). It ensures good quality industrial products, while bringing down the cost of manufacture. A third category of applications is in industrial, hydrological or biological systems, which is based on the tracer principle. and is known as radiotracer applications (Ease of detection of radioisotopes in extremely small quantities makes them useful as tracers for investigation of biological, industrial and environmental processes). Keeping in mind the ALARA (As Low As Reasonably Achievable) principle, which basically involves a risk-benefit analysis to achieve low radiation dose level, for the particular application, the following radiation source properties could be considered:

- (a) Category or physical form
- (b) Radiation type
- (c) Energy and spectral purity
- (d) Intensity
- (e) Half-life
- (f) Chemical form and compatibility with process stream (tracers)
- (g) Availability, classification and cost

Radioisotope source may be used as sealed source, where the radioisotope remains permanently within an encapsulated form and makes no direct contact with the process material, and/or as open source, where it is not encapsulated and is used for various applications in industry and healthcare.

Industrial Applications of Sealed Sources

Radioactive sealed sources have been used for several years for a wide range of applications in a variety of shapes, sizes and radioactivity levels. In Industry, they are widely used for non-destructive testing (NDT), radiation processing, 'on-line' process control systems, 'on-line' elemental analysis, smoke detection, etc. In medicine, they are commonly used in teletherapy and brachytherapy for the treatment of malignant diseases, and for bone density measurements.

In research, a variety of sources are used, for different applications most commonly, for elemental analysis (i.e., X-ray and neutron activation analysis) and material structure studies. Radionuclides commonly used for industrial sealed sources are ^{60}Co , ^{63}Ni , ^{90}Sr , ^{137}Cs , ^{147}Pm , ^{169}Yb , ^{170}Tm , ^{192}Ir , ^{241}Am and others. The demand and scale of industrial applications of sealed sources, such as ^{60}Co seems to be the highest, whereas, the demand for ^{137}Cs is mainly for its use in blood irradiators and hence stable, and the need for ^{192}Ir sealed source is expected to increase in the coming years.

Sealed source assembly are radioactive materials that are encapsulated, usually in stainless steel capsules or pencils, and makes no physical contact directly, either with the plant or the process material. These sealed sources emit ionizing radiation only through the capsule wall which is directed at object, and by analyzing the modified radiation pattern, either in transmitted or in scattered beam, it is possible to draw conclusions about the internals of the test sample. For high energy γ -emitters, such as ^{137}Cs , ^{192}Ir and ^{60}Co , the capsule can be usually made using appropriately thick stainless steel, as the γ -radiation can still exit the capsule without significant absorption. Radionuclide based instruments or equipment, such as radiography cameras, gamma chamber and blood irradiators, have been extensively used in industry. Radiation technology equipment based on ionizing radiation emitting radionuclides offer following advantages:

- Radiation being penetrating, the measurements are made without direct physical contact of the source with the material being measured
- On-line, non-destructive measurements can be done on moving material
- The source is stable and little maintenance is required
- Substantial cost-saving

For industrial use, various sealed radiation sources supplied by BRIT:

- **Iridium-192:** ^{192}Ir , [Chemical form: Ir, half-life: 74.3 days γ/MeV – 0.31; 0.47 & 0.60 and main $E\beta/\text{MeV}$ 0.54; 0.67], is a useful radioisotope for use in radiography techniques, mainly for the examination of a variety of industrial products. BRIT uses high specific activity ^{192}Ir for radiography cameras as most of the radiography cameras have the capacity of loading upto 120-150 Ci.
- **Cobalt-60:** Highly penetrating gamma rays from radioactive ^{60}Co source [Chemical form: Co, half-life: 5.27 years, $E\gamma/\text{MeV}$ – 1.33 and 1.17 and main $E\beta/\text{MeV}$ 0.31], is another important radioisotope for gamma radiography for non-destructive examination in industries. The radioisotope in sealed source form (with varied specific activities) is also useful for low-dose laboratory irradiators, nucleonic gauges, radiation processing plants for irradiation of food and medical products, and teletherapy machines.
- **Cesium-137:** [Chemical form: CsCl, half-life: 30 years, $E\gamma/\text{MeV}$ – 0.66; and main $E\beta/\text{MeV}$ - 0.51], obtained from the high level liquid waste (HLLW) obtained after reprocessing of spent nuclear fuel and vitrified in glass pencils (at BARC). The vitrified glass pencils are encapsulated inside the SS tubes and welded from both sides to form ^{137}Cs sealed sources which are successfully used in low-dose application for blood irradiators supplied by BRIT.

A. Radioisotopes (as Sealed Sources) in Non-Destructive Testing (NDT)

I. Industrial Gamma Radiography

Use of isotope radiography for NDT implies that the technique is to be used for detecting, locating, characterising and sizing of defects in industrial systems. Such equipment is designed and fabricated to meet the requirement of relevant industry codes and standards. The discovery of the ability of radiation to penetrate matter and form images on photographic plates, opened up great potential in both medical as well as industrial fields worldwide. Industrial radiography for non-destructive testing of welds, castings, pipelines and components, has grown into a major activity during the years.

Utilisation of radioisotopes for industrial application was one of the early verticals in the Indian nuclear programme. Use of radiography technique for testing of flaws in welds and castings had been started in India, way back in 1957, during the construction of the CIRUS reactor. Radiography uses the radiation attenuation principle and estimation of transmitted radiation to detect flaws in the material. With the establishment of many high-flux nuclear reactors, a variety of isotopes are now available. Most commonly used sealed sources for radiography are ^{192}Ir and ^{60}Co . However, depending on the requirements, radioisotopes such as ^{137}Cs and ^{241}Am may be used. Linear accelerators and betatrons, which are capable of providing high energy and high intensity X-ray beams are also used for inspecting thick materials (upto 500 mm steel equivalent) in short exposure times. Advantages of use of isotope sources for radiography testing over X-ray machines, are the ease of portability, no requirement of electric power on site and the possibility of use of tiny isotope sources, in otherwise, inaccessible areas of industrial system.

The importance of the technology was realized and its indigenous development was started. Fabrication of radiography sources was initiated only after the successful production of Ir-192 and ^{60}Co radioisotopes, first in APSARA reactor, and subsequently, on a larger scale in CIRUS reactor. Parallely, radiography cameras using Ir-192 (most common) and ^{60}Co (for high density, thick objects) were developed in 1960s and made available to the industry. A lot of evolution has taken place in this field since then and the first indigenous remotely operated camera model, ROLI-1, has become the workhorse for industry. These cameras cover an inspection range of 10 to 70 mm of steel. As the use of this technology grew, it was ensured that the cameras also kept

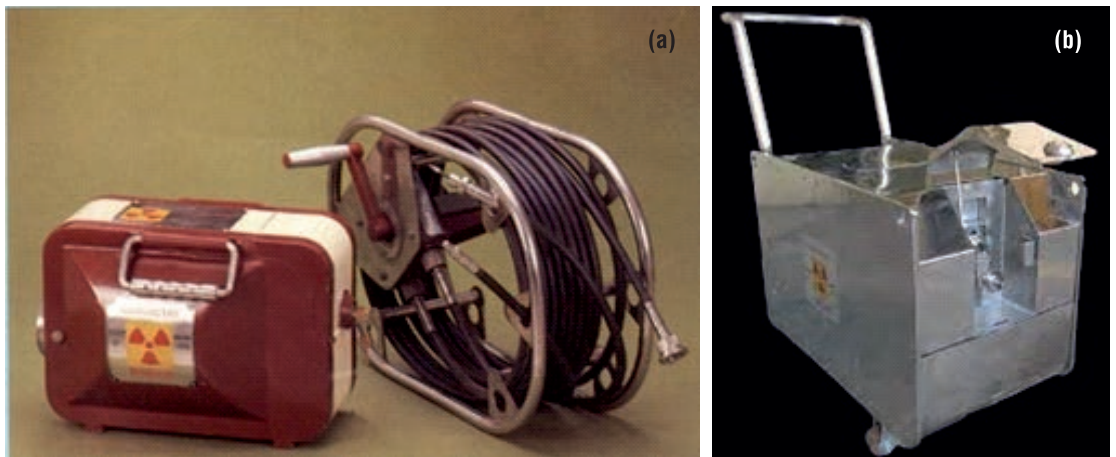

Fig. 1: Radiography devices supplied by BRIT: (a) ROLI-2 and (b) COCAM-120

improving. Launch of improved versions and completely indigenous gamma radiography exposure cameras, ROLI-2, with higher capacity, and more recently during 2021, the launch of COCAM-120, with Cobalt-60 sources, hence, improving the inspection range to 40 to 200 mm has brought BRIT to newer heights for its service to industries. Various types of radiography cameras supplied by BRIT are shown in Table 1. The supply of radiation sources for these cameras as well the imported cameras has also been maintained to the satisfaction of industry. It must be noted that radiography is the most preferred technique for non-destructive testing of all welded joints and castings. Use of 2500 radiography cameras in India demonstrates its use for quality control parameter to every conceivable industry. DAE is in the forefront for the development of radiography cameras for Non-Destructive Testing (NDT).

Table1: Details of Radiography Cameras offered by BRIT

| Specification | ROLI-2 | ROLI-3 | COCAM-120 |
|-----------------------------------|---|---|---|
| Isotope | Iridium - 192 | Iridium - 192 | Cobalt-60 |
| Half life | 74 days | 74 days | 5.27 years |
| Maximum capacity | 2.4 TBq. (65 Curies) | 0.74 TBq. (20 Curies) | 4.4 TBq. (120 Curies) |
| Inspection range | 10 mm to 70 mm steel or equivalent | 10 mm to 25 mm steel or equivalent | 40 mm to 200 mm steel or equivalent |
| Shielding material | Lead & heavy alloy | Lead & heavy alloy | Lead, heavy alloy & depleted Uranium |
| Camera operation | Remotely operated (Teleflex cable drive) | Remotely operated (Teleflex cable drive) | Remotely operated (Teleflex cable drive) |
| Maximum operating distance | 8 meters from the camera | 8 meters from the camera | 14 meters from the camera |
| Front guide tubes (2 Nos.) | 3 meters and 1 meter long (one each) | 3 meters and 1 meter long (one each) | 3 meters long |
| Overall dimensions | 375 mm long, 250 mm wide, and 275 mm height | 530 mm long, 370 mm wide, and 181 mm height | 375 mm long, 250 mm wide, and 275 mm height |
| Package | Type B (U) | Type A | Type B (U) |
| Weight | 38 kg (approx.) | 25 kg (approx.) | 316 kg (approx.) |

Recently launched COCAM-120, the Cobalt-based camera with hybrid shielding, has become a boon for the heavy engineering industry where welding of large thick plates is frequently used. Servicing, maintenance and source replenishment of these cameras is also carried out by BRIT, on a regular basis.

At present, ^{192}Ir and ^{60}Co radiography sources are fabricated in the RLG hot cells of BRIT inside the BARC campus. The present demand is 1200 sources/y. The growth in demand for radiography sources has a high correlation to the growth rate in infrastructural industry and a steady demand is expected over the next 25 years.

II. Industrial Computed Tomography (ICT)

Taking cue from medical tomography, such as, magnetic resonance imaging (MRI) and ultrasound, a similar technique has been developed for non-destructive testing of engineering and industrial specimens. An experimental prototype computer tomographic system (CITIS) had been set up at Isotope Division, BARC, using a 7 Ci (260 GBq) source of ^{137}Cs and a NaI (TI) scintillation detector. This system provided a unique cross-sectional image of the internal structure of test objects. The method involves collection of transmission data of the penetrating radiation through an object at different planes and subsequent reconstruction of a 3-D image using the two-dimensional planar profiles of the effective linear attenuation coefficients at designated points. The computed tomography imaging system consists of a gamma ray sealed source, a collimated detector assembly, a precisely controlled mechanical manipulator and a data acquisition system along with a PC. This prototype unit is capable of scanning specimens of small diameters (upto 100 mm) and of varying densities. The system has been upgraded with an X-ray source and an array of cadmium tungstate detectors. Industrial Computed Tomography system is expected to be useful for NDT of a number of precision components for cross-sectional examination (3-Dimensional) of various objects like reactor fuel assemblies and solid propellants in rocket motors. Computed tomography using neutron source is gaining importance for material characterization. Unlike X-rays and gamma rays, neutron attenuation is generally higher for low atomic number elements and vice versa. This property makes neutron CT inspection more advantageous in certain cases where conventional X- or gamma ray techniques have limitations.

Industrial Electron Linac: Electron accelerators from 500 keV to 10 MeV energy are employed for surface irradiation, food preservation, medical sterilization, cargo scanning and other industrial products. BARC has indigenously developed cargo scanners for inspecting and identifying goods in transportation systems by employing high power electron beam accelerators. Cargo scanners are required at different locations in the country for checking incoming and outgoing cargo. Because high energy X-rays are required to penetrate the cargo, an electron linear accelerator is used as the X-ray source. Linac-based cargo-scanning systems have three main components – the X-ray source, the detector array and the conveyor. In these systems, the accelerated electron beam is made incident on a tungsten/tantalum target to produce X rays, which are then used for scanning purpose. A 9 MeV linac cargo-scanning system has been set up at ECIL, Hyderabad, and a 6 MeV compact linac cargo scanner has been set up at Trombay, Mumbai. BARC has also demonstrated the use of electron beam irradiator for waste water treatment by DC accelerator and medical sterilization/food irradiation using electron beam LINAC.

III. Gamma-Ray Scanning

Distillation columns, extraction, stripper and related systems are critical components in petroleum refineries, gas processing installations and chemical plants. Malfunctioning of any of these industrial columns can lead to fire hazards and atmospheric pollution, in addition to resulting in huge revenue losses. Many problems can develop during the operational life of these systems, which may lead to mechanical damage to their internals, or problem may arise in the process itself. In conventional trouble shooting tests, it will be essential to shut down the plant before any inspection is undertaken, which will add on to production losses.

For process diagnostics of distillation columns, interface measurements are frequently carried out by γ -ray scanning. Gamma-ray scanning, using a radiation sealed source, is a non-disruptive and on-line inspection technique, which is used to diagnose process malfunctions or assessment of internal damage within industrial distillation process columns in petroleum refineries and chemical plants.

In practice, a collimated sealed radioactive source and detector are positioned in the horizontal plane, either across the diameter (in tray type column) or across the different equi-length chords (in packed bed columns). Both, the source and detector are then moved synchronously along the length of the column and radiation intensity is recorded at desired elevations. Analysis of the data with reference to the internal loading and hardware configuration of the columns gives valuable information about the column. 'Signature scans' obtained at normal working or at pre-commissioning trials could be used for comparison and to derive useful information of the internal configuration of the column.

Gamma scanning technique is rapid, versatile, accurate and have wide applications in trouble shooting, debottlenecking, predictive maintenance and for design optimization of industrial columns.

In India, gamma scanning technique was initiated in 1995, under MoU with the Engineers India Ltd [EIL]. Isotope Application Services (IAS) was started by BRIT in the Year 2007 on commercial basis. Presently, IAS, BRIT, offers required gamma scanning services to industries for on-line troubleshooting and process optimization of industrial process columns. Over 180 columns of different types including tray and packed beds upto 10 m diameters have been investigated, resulting in savings of several hundred crore of rupees to Indian industry. About 30 major petroleum, petrochemical and chemical process industries have benefitted from the gamma scanning technology.

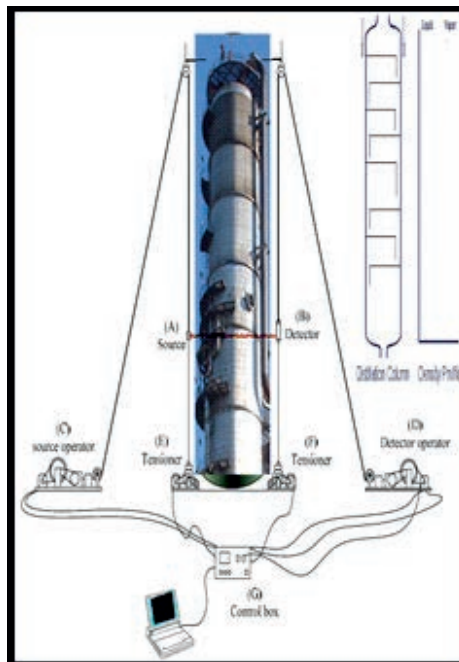

Fig. 2: Gamma-ray scanning process

IV. Nucleonic Control Gauges

Chemical industries, refineries, oil platforms, mining and mineral industries make extensive use of sealed source radioisotope-based gauges and have found radiometric density and liquid level gauges applicable to solve many of their problems. These gauges are based on the principle that radiation transmission through or scattering from a material as a function of its properties, i.e., when γ -rays travel through matter they are attenuated to an extent that depends upon the density and composition of the matter and the distance the rays travel in it. During the manufacturing process, it is possible to measure and monitor thickness of sheet materials, such as films and sheets of metals and plastics, by proper selection of γ -rays of the correct energy. Radioisotope-based gauges, such as thickness gauges, level gauges, density gauges and moisture gauges are put in for practical purposes such as monitoring during the manufacture process, quality control checks and inspection. These gauges can improve process efficiency, assume an important role in quality control and thus yield large savings through avoidance of several types of losses during production.

The level of liquids in closed or large tanks can be conveniently measured and controlled using radioisotope gauges kept external to the tanks. Basically, a γ -ray sealed source (such as ^{60}Co or ^{137}Cs) and a miniature radiation detector are inserted simultaneously down adjacent tubes in the bundle, and the radiation transmitted through the tube walls is recorded. When carrying out this procedure for each pair of tubes, a comprehensive picture of the position and degree of the corrosion over the entire bundle can be recorded. The technique has an advantage of being rapid compared with other inspection methods and is capable of high accuracy. The scanning of heat exchanger bundles, performed using radioisotope gauge, is often incorporated into many plant shutdowns, so that the extent of corrosion can be observed.

Chemical companies use radioactive density gauges for routine, continuous measurements process materials such as hot brine, sulfuric acid, milk of lime and organic compounds. In most of these instances, the reasons for installing a radioactive density gauge have been that it is more precise, accurate, less time consuming, less susceptible to human error, or much safer than the conventional methods. Density gauges have also been used effectively in aiding the control of certain processes, such as, during polymerization of butadiene and styrene, it is important to know the density of the product in order to measure the degree of polymerization. Density gauges, in such cases, would provide the direct means of controlling the process.

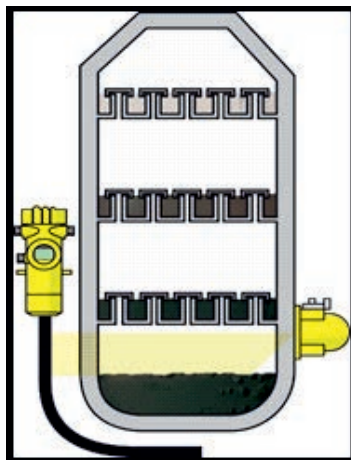

Fig. 3: Radiation-based level measurement by Nucleonic Gauge

Similarly, radioactive density gauges have been used by the rubber industry to measure and control the density of foamed latex. Typical products gauged include rubber-coated tyre fabric, rubber floor covering, pressure-sensitive rubber adhesive tape and rubber sheeting. In these cases, the radioactive thickness gauge has replaced magnetic capacitance, radio-frequency, and air-operated gauges. The advantages are those common to most radioactive thickness gauge applications including closer tolerances, continuous operation, being independent of operating temperature and humidity, as well as independent of composition and hardness of the product. Rubber companies using such gauges have reported savings attributable to more efficient use of materials, less scrap production and reduced labor requirements.

B. Radioisotopes (as Sealed Irradiator Sources) for Radiation Processing

Some of the most promising areas for application of sealed radioactive sources are sterilization of medical products, food preservation, hygeinization of sewage sludge, etc. Radiation processing essentially is an application based on the principle of radiation chemistry. High-energy ionizing radiations have unique ability to produce reactive, short-lived ionic and free radical species at any temperature and in any phase – solid, liquid or gas, in a variety of material. These reactive species induce many chemical reactions. This property of ionizing radiation has been beneficially used for various industrial processes such as modifying the polymerization processes. The ability of radiation to destroy micro organisms by reacting with DNA molecules of growing cells is effectively harnessed for several radiation processing applications, such as, sterilization of medical products, disinfestation of food and food products and treatment of sewage sludge.

Radiation processing involves controlled application of energy from ionizing radiations. This can be either radioisotope based or particle accelerator-based. Gamma rays and X-rays are radiations with short wavelength of the electromagnetic spectrum. Gamma rays are emitted by radioisotopes such as cobalt-60 and caesium-137, while electrons and X-rays are generated by machines using electricity. Gamma rays can penetrate deep into food materials and bring about desired effects.

Table 2: Sources (with their energy) used for radiation processing.

| Source | Type of radiation | Energy (MeV) |
|----------------------|-------------------|---------------|
| Cobalt -60 | Gamma rays | 1.17 and 1.33 |
| Cesium -137 | Gamma rays | 0.66 |
| Electron beam | Electron s | Up to 10 MeV |
| X-rays | X-rays | Up to 5 MeV |

I. Radiation Sterilization of Medical Products and Food Irradiation

Sterilization of medical products by ionising radiation is an economically viable alternative to conventional sterilization methods, such as, dry/wet heat or treatment with ethylene oxide (EtO). Unlike the conventional heat energy, which is mainly deposited in the translational, rotational and vibrational modes of the absorbing molecules, these high-energy radiations mainly interact with the orbital electrons and excites absorbing molecules to higher excited

states, which results in formation of highly reactive ions or radicals. EtO is also a surface sterilant, and, is not effective for killing entrapped or deep-seated micro organisms. Products sterilized by this method will also contain residual EtO and its reaction products. The major advantage of radiation sterilization, mainly using Cobalt-60 (~1 MCi capacity), is that heat resistant and bulky materials can also be effectively sterilised by the penetrating radiation. This technique is mainly a cold process. It is used for disposable medical devices made from heat-sensitive plastics. A dose of 25 kGy is delivered to the products to be sterilized in sealed packages to achieve sterilization. The gamma rays penetrate through these sealed packages and destroy micro-organisms.

The ISOMED plant at Trombay, set up in 1974, under a UNDP project, for sterilization of medical products, gave a very early lead to BARC (and BRIT) in building expertise in operations of gamma radiation plants. This facility houses 1 MCi ^{60}Co source, and which over the years, has gained tremendous popularity and acceptance in society, mainly due to its simplicity and reliability. It has provided ample services to Indian pharma industry (large corporates, small and medium companies, entrepreneurs and researchers) and been the forerunner to a few other plants, which came up subsequently in Delhi (Shriram Institute of Industrial Research, still in operation) and Bangalore (adjoining a cancer hospital - KMIO); now decommissioned.

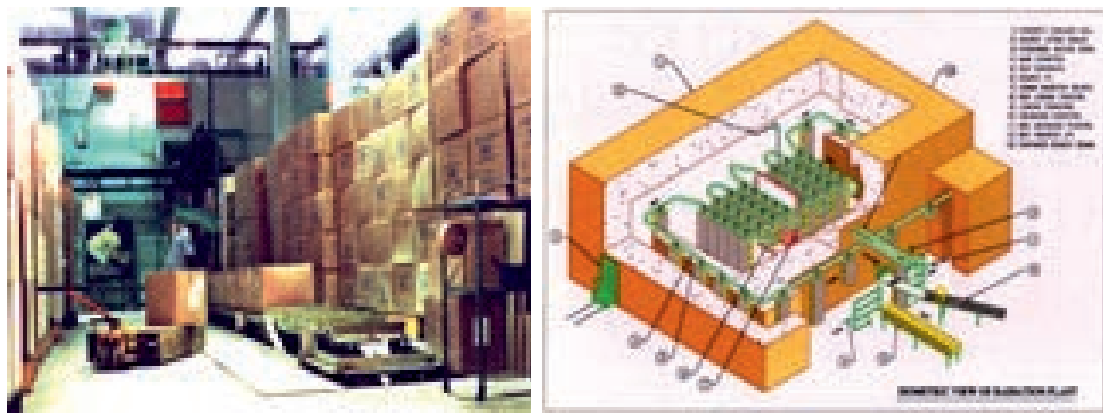

Fig. 4: ISOMED Facility (BRIT) for Sterilization of Medical Products

The first approval for radiation treatment of food products was accorded in 1994, by the Government of India. DAE has since then set up two industrial scale technology demonstration irradiation plants. One gamma radiation plant indigenously designed and built by BRIT in the Year 2000 (1 MCi ^{60}Co capacity) is in commercial use since its inception at Vashi Complex for radiation disinfestation of spices and several other food-products (30 ton per day) requiring medium to high radiation doses (upto 14 kGy). Similarly, another demonstration of gamma irradiation plant for applying low dose irradiation (capacity 10 ton per hour), to prevent sprouting in onions (and potatoes), was also indigenously built and commissioned by BARC in Lasalgaon, near Nashik, in the Year 2002. This plant was upgraded for processing of mangoes for export to USA in 2007. Ever since then, it is being used for phytosanitary treatment of (Alphonso) mangoes.



Fig. 5: Radiation Processing Plant (RPP) at BRIT, Vashi Complex

Utilising the technological support rendered by DAE, through BRIT, there are over 26 gamma radiation-based food processing units (0.5 to 1 MCi capacity) operating in private sector (in most cases handling both food and medical products). Another 7 units are under construction. DAE Units' developed indigenous plant designs and technologies developed by DAE units are being made available on technology transfer (low cost, non-exclusive) basis. Life-time supplies of ^{60}Co sources for these plants are envisaged to be made available by BRIT.

Electron accelerators, also called electron beam (EB) machines, form the alternate technology to gamma plants for radiation processing technology. They can provide variable energy from a few 100 keV up to 10 MeV and also variable dose rate to exactly match the requirement of product(s) to be (radiation) treated. Use in both electron mode and X-ray mode is possible, the latter involving high-Z target system (e.g., Ta) to enable availing of Bremsstrahlung radiation (continuous energy X-rays) and help overcoming penetration limitation of electron radiation. All EB system require stable and reliable high-quality electrical power supply. They do not have limitation of source strength aspect of radioisotope (c.a., ^{60}Co) or issues of high-intensity RI source movement/transport.

RRCAT of DAE has an active programme related to indigenous EB system development and utilization. A system has been installed in Indore agro-market area, which is the first large-capacity indigenous electron accelerator-based radiation processing facility for food and agro-products.

Presently, irradiation sources are being supplied by BRIT for industrial and laboratory irradiators. ^{59}Co is loaded in nine 220 MWe reactors of NPCIL. It is proposed to load ^{59}Co in the 700 MWe reactors as well. Another facility is being set up at Kota for the handling of absorber rods of 700 MWe reactors. The activity generated is sufficient for present and future requirements.

The facilities available are one pool, two hot cells for recovery of ^{60}Co and two hot cells for fabrication at RAPPCOF, Kota. Another facility at HIRUP, BARC is being used for the fabrication of sealed sources. A new hot cell facility is started, namely, IFRT at BRIT for carrying out these jobs.

II. Sludge Hygeinization

Water-borne community wastes, which are composed of drain water, and consists of human waste discharged from domestic premises, industrial wastes, etc. is cumulatively known the sewage sludge wastewater. It is composed of nearly 99.9% water and 0.1% pollutants, by weight. Even if the wastewater contains only a very small part of pollutants, these may endanger public health as well as the environment. Many disease-causing pathogens in sewage sludges, such as, viruses (e.g., polio virus), parasites (worm eggs, e.g., taenia), and bacteria (e.g., salmonellas), in addition to organic and inorganic matter can enter from almost anywhere in the community. These pathogens often originate from people and animals that are infected with, or, are carriers of a disease. For economic considerations, recycling of wastewater, which has high percentage of organic matter, nutrients and trace elements, stands important, but only after proper treatment. World over, many studies have proven effective utilization of ionizing radiation for environmental remediation, especially hygeinization of sewage sludge. Treatment of sludge is very important before being released for use as manure.

Radiation technology is a promising alternative, because it has high efficacy to inactivate pathogens; is effective to oxidize organic pollutants, eliminate odor, etc. This, in turn, will facilitate the down-stream process of sludge treatment and disposal. Radiation dose of $\sim 8\text{-}10$ kGy is found to reduce the pathogen concentration in dry sewage sludge. Gamma rays penetrate well in water and sludges; the half value thickness of the gamma rays of ^{60}Co (1.3 MeV) is about 28 cm in water and not less than 25 cm in normal liquid sludges. Penetration of gamma rays assures irradiation effect in the total quantity of sludge. ^{137}Cs (as CsCl) can also be used as gamma source for this purpose. Radiation energy of this source is 0.66 MeV, with a half value thickness of 24 cm in water. As CsCl is water-soluble, it is regarded as less safe in case of the source leakages or accidents. Thus, ^{137}Cs is not widely used as sealed radioactive source in gamma irradiation plants that require high activity. Use of radiation technology has shown advantages over conventional methods of aerobic and anaerobic digestion, which do not reduce the pathogen concentration to safe levels. Due to reduction of microbial load, the hygienized sludge can be inoculated along with the useful bacteria, to result in value-added biofertilizer. Both, ^{60}Co gamma sources and electron accelerators can be used for irradiation of sewage sludge. Gamma sources have better penetration allowing thicker layers of sludge to be irradiated, although they are less powerful and take longer irradiation time than electron sources. Sludge Hygeinization Research Irradiator (SHRI) Facility of DAE located at Baroda, Gujarat, uses ~ 150 kCi ^{60}Co source for treatment of sewage.

III. Treatment of Flue Gases

Municipal and industrial activities lead to environment degradation. Flue gas is the gas released to the atmosphere via a flue, which is a pipe or channel for conveying exhaust gases from a fireplace, oven, furnace, boiler or steam generator. High concentrations of pollutants like Sulphur dioxide, oxides of Nitrogen and particulate matter from the emission of flue gas, which is released from coal or oil-fired boilers in power stations and engineering industries, result in environment degradation. There are conventional and emerging techniques to remove toxic components from the gas effluents, i.e., chemical and radiation techniques. Among conventional methods, a combined technology of selective catalytic reduction of NO_x by Ammonia and

neutralization of SO_2 by $\text{Ca}(\text{OH})_2$ is most frequently used. Radiation techniques, using electron beam technology and/or gamma ray irradiation, generally using ^{60}Co , to convert the gaseous pollutants into useful fertilizer constituents like ammonium sulphate and ammonium nitrate, are also being used. Flue gas from a boiler is passed through a mechanical filter and saturated with water vapour before admission into an irradiation chamber. In presence of radiation and Ammonia, gaseous oxides get converted to their salts. A radiation dose of $\sim 10\text{-}20$ kGy is required for this purpose.

C. Teletherapy Sources of ^{60}Co

Radioisotopes and radiation technology have provided tools for cancer treatment. Teletherapy involves use of radioactive material, such as ^{60}Co sealed source, for production of an external beam of gamma rays for treatment at a distance from the radioactive source ('tele', meaning "at a distance"). Cobalt teletherapy units are used for delivering strong dose of gamma radiation to the affected parts of the body. For tumour treatment by teletherapy, only the collimated beam of ionizing radiation emanating from the radioactive sealed source is directed towards the tumour, where the ^{60}Co source is placed in the shielded housing. The patient remains stationary, and the area of treatment is at the centre of the orbit of the source head, while the source head can be moved and fixed in any desired position. The radiation source commonly used is ^{60}Co , because of the desired nuclear characteristics, like, high specific activity, high radiation output per curie and long half-life.



Fig. 6: ^{60}Co Teletherapy Unit

BARC had taken up initiative to indigenously develop cobalt-based teletherapy systems, which resulted in the launch of 'Bhabhatron', in 2007. The technology was later transferred to a private company in Bangalore. Over 40 Units are in operation, in India and abroad. BRIT supplies cobalt teletherapy sources to a large number of Cancer hospitals in the country. In near future, BRIT is also going to launch, the indigenously made HDR Brachytherapy unit, 'KARKNIDHAN' with ^{192}Ir source.

Earlier teletherapy sources were fabricated and supplied to users in India using imported ^{60}Co . About 200 kCi teletherapy sources are now prepared using indigenous ^{60}Co , to meet average 12-15 replenishment source needs per year. At present 15-20 sources per year are supplied. Also, over the years, BRIT has obtained export orders of ^{60}Co .

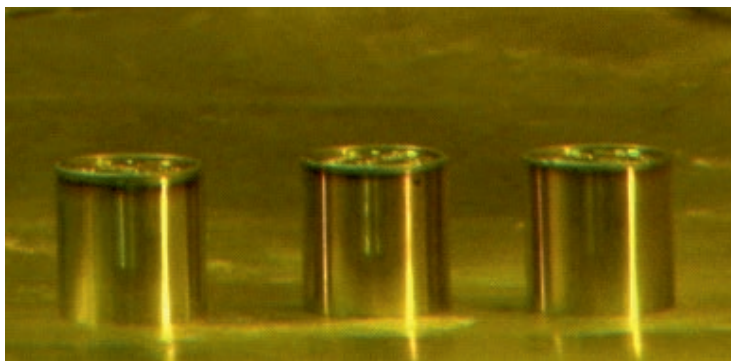

Fig. 7: ^{60}Co Sealed Sources (CTS) for Teletherapy Machines

Import of ^{60}Co teletherapy sources (CTS) is not required and BRIT supplies > 250 kCi high specific activity CTS, thanks to NPCIL's NPPs which are operating at consistently higher capacity factor. Also, storage capacity at RAPP COF has been increased and BRIT can meet the growing demands.

D. Laboratory Research Irradiators & Blood Irradiators

The laboratory research Irradiator, called gamma chamber (GC), is one of the engineering equipments supplied by BRIT. It contains ^{60}Co source and an irradiation chamber of a few litres capacity. It has been instrumental in supporting radiation research studies including food preservation, phytosanitary support for trade or shelf-life extension, polymer/composite development, treating seeds for preparing crop mutants, etc. Since 1990s, BRIT has developed and supplied gamma chambers (e.g., GC-5000 of 14 kCi ^{60}Co , 5 L chamber volume) to facilitate such applications in India and abroad.



Fig. 8: Low Dose Irradiator

Low dose rate gamma chamber unit of ^{60}Co has also been used for blood irradiation (BI), for ensuring safety of transfusion to immuno-compromised patients. More recently BI units containing BARC-developed vitrified ^{137}Cs source have been developed and supplied. Use of ^{137}Cs (half-life: 30 y) obviates the need for source replenishment required in the case of ^{60}Co -based BI units.

E. Industrial Radiotracer Techniques

Minute quantities of radioactive substances can be precisely measured and this is exploited in collecting all the information about spatial and temporal distribution of the tracer in a system. Achieving high degree of specificity and sensitivity are two major factors common to most tracer applications. The radioactive material sent as a tracer can be "traced" by using radiation detection instruments, even though it may be chemically and physically identical with the other material in the process.

Because radioisotope tracers can be used *in-situ*, its capability for detection of blockages, leakages or seepage, estimation of mean residence time, residence time distribution, flow rate, mixing/blending time evaluation, etc., can be very useful to industries. Mechanism and kinetics of chemical reactions, important phenomenon like catalysis, adsorption and absorption, chemical exchange, solvent extraction and polymerization, etc. can all be studied in detail, using radiotracers. Industries which presently employ tracers, include coal, oil, natural gas, petrochemical, cement, glass, rubber, building materials, ore-processing, paper and pulp, iron and steel, and automotive industries.

Object to be studied is labeled with radiotracers prior to the experiment and either by following the trace movement, changes in concentration or distribution between phases, measurements/studies such as material conditions, flow rate measurements, wear rate studies, residence time distribution (RTD), leak detection in buried pipelines & high pressure heat exchanger systems, diffusion rates, etc. may be studied. Gaseous/liquid radiotracers are used for these studies and selection of suitable tracer for a particular study needs careful evaluations of material parameters, reaction mechanisms and kinetics. Tracer studies are also widely used in physical and chemical research. ^{82}Br ($t_{1/2} = 36$ h), ^{46}Sc ($t_{1/2} = 84$ d), ^{24}Na ($t_{1/2} = 15$ h), ^{41}Ar ($t_{1/2} = 110$ min) and ^{203}Hg ($t_{1/2} = 46.6$ d) are extensively employed as industrial tracers.

I. Leak Detection, Detection of Blockage in Buried Pipelines & Maintenance

The tracer method is particularly useful for buried pipelines since alternatives such as radiometry are possible for the over ground pipelines.

Free flow of materials in pipelines and other industrial systems are obstructed due to blockages, which may occur due to variety of reasons, such as, involuntary introduction of foreign materials during construction and because of scaling on walls during operation. Leakages may occur in the pipelines due to corrosion or faults in the joints. These defects can lead to operation of plant at much lower efficiency causing substantial economic losses. Radioactive tracer technique offers elegant approaches for easy detection and location of blockages and leakages.

- Leak detection in buried pipelines and movement or location of specific objects in underground pipeline

The leakage in long and buried pipelines or those in industrial plants can be monitored with a suitable short-lived isotope like ^{82}Br ($t_{1/2} = 36$ h). The radiotracer is injected into the pipeline and the velocity of fluid flow is measured in different section of the pipeline by monitoring the time

taken by radiotracer to pass different points along with pipelines. The drop-in velocity in any particular section is indicative of blockage in the pipeline.

Alternately, the pipeline is filled with the radiotracer solution, which is pressurized so that a small quantity of radiotracer leaks into the soil at the point of leak. Subsequently the pipeline is flushed with water and a portable radiation monitor, when moved along the entire length of the pipeline, identifies the point of leak. Even minute leaks spotted by this method, results in huge savings and manpower. Likewise, any leaks in dams and reservoirs, may also be detected.

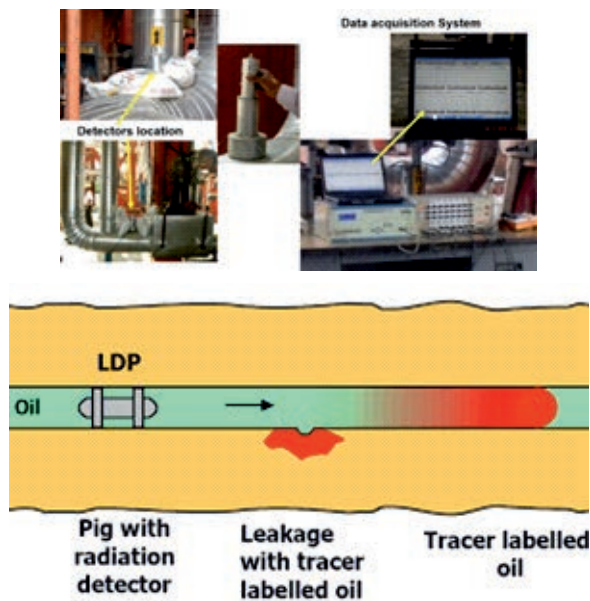

Fig. 9: Leak Detection using Radiotracers

Radionuclides are also used to determine the movement or location of a specific object, such as cleaning tool or scrapper in an underground pipeline. The radioisotope is used as a sealed source attached to the object to be traced. As the object moves through the pipeline, its movement can be traced on the surface by scanning the ground with an appropriate radiation detection instrument. This application is extremely useful in tracing the uncharted course of a pipeline system or in locating an obstruction in the pipeline, thus avoiding huge expenditure that would be otherwise required to excavate the entire line.

- **Leak detection in high-pressure heat exchanger systems**

In an industrial heat exchanger system, two process fluids flow in opposite direction through the two independent sub-systems exchanging the heat. There are multiple heat exchangers in the system and many times, there is significant pressure difference between the two sub-systems. For high pressure systems, there are no tapping points and hence it is not possible to identify the leaky heat exchanger with conventional methods if there is a leakage.

In such cases, radiotracers can be very effectively used for identification of leaky heat exchanger. A radiotracer with compatible physicochemical properties and suitable radioactivity is injected into the high-pressure side and the low-pressure side is monitored for presence of leaked radiotracer. The leaky heat exchanger is identified unambiguously.

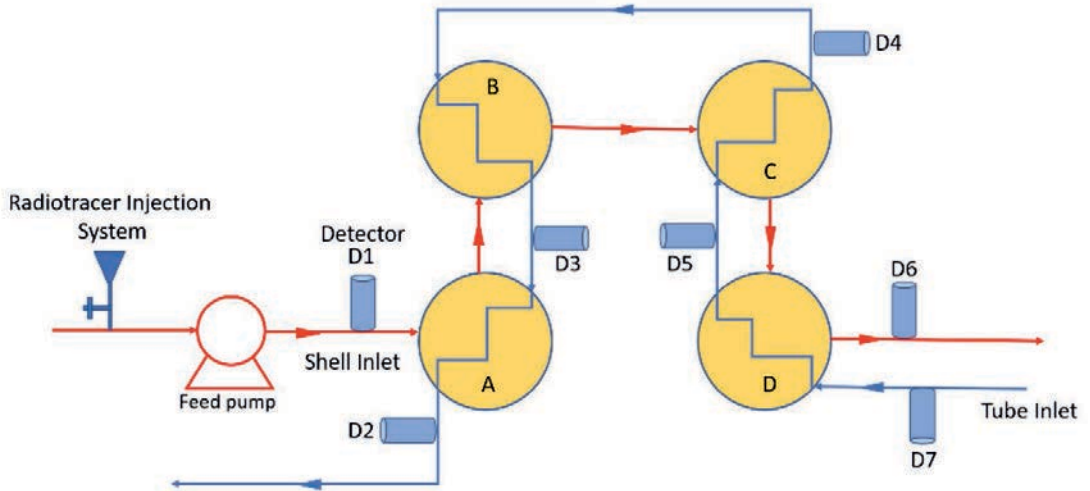

Fig.10: Experimental set-up for Identification of Leaky Heat Exchanger

II. Process Investigation Parameters

A major application of radiotracers is the residence time investigations to determine limits for chemical plant optimizations, modeling and automation. Continuously operating industrial systems are designed to have certain fixed pattern of flow parameters. Deviations from the optimum flow parameters affect the quality and efficiency of process. The deviation may be due to either malfunction or due to efficiency of the process. Hence, estimation of residence retention distribution (RTD) is one of the important parameters that can provide information on the characteristics of the reactor, such as the flow pattern that occurs, diagnose possible system malfunctions, such as presence of dead or foul volume, bypassing, leakage, blockage, channeling, and back-mixing, and to help estimate the quality of mixing. The RTD, which depends on flow hydrodynamics and reactor geometry, influences the chemical reactor performance by affecting reaction properties, use conversion and yield. The RTD can be measured by evaluating the concentration of a tracer, usually a short-lived radiotracer like ^{82}Br in a suitable chemical form, which is added as a stimulus at the system inlet. At the outlet, the detector connected to a data acquisition system is placed to record the data. The mean residence time (MRT) of the reactor could be estimated from the time taken between the two measurements. From the MRT and by knowing other parameters of the reactor, the effective volume of reactor can be determined. Difference in effective volume and standard geometric volume will give the information about the functioning of the reactor.

Tracer experiments would indicate the deviations from optimum conditions, once the optimum performance of the plant has been attained. The reasons for malfunctions, such as, undesirable by-pass streams or obstruction of vessels and pipes can be determined and remedied. Necessity for a plant shutdown can be assessed and vital information for required repairs may be obtained prior to shut down.

III. Flow Rate Measurements

A common tracer application is to provide flow rate information introducing radionuclide directly into the moving material, generally a liquid. This originated with the petroleum industry, and was designed to mark the interface between two different petroleum products being pumped through a pipeline that may handle as many as twenty different products in sequence. A small amount of radionuclide is introduced at a pumping station, just before a new product is pumped into the line. Radiation detectors located along the pipeline indicate when the radionuclide, and hence the interface between the two products, passes. This technique is reliable, even though the switching station may be several hundred miles away from the pumping station, where the radionuclide is injected. It is also faster, more accurate and less costly than alternative techniques.

IV. Mixing

One of the main applications of radiotracers in chemical and cement industries is measurement of homogeneous mixing efficiency. In order to obtain a predetermined degree of homogeneity, mixing involves blending of two or more miscible fluids. Process industries use stirred tanks to accomplish many different operations, including the blending of miscible liquids into a single liquid phase, suspension of solids, promotion of heat and mass transfer, gas-liquid and liquid-liquid mass transfer, crystallization and chemical reactions. When a mechanically stirred vessel is used, numerous purposes must be fulfilled. Using radiotracers, some of these objectives, including the homogenisation of single or multiple phases at a specific temperature and concentration of components, which can be affected by the physical properties of fluids that are being mixed, can be studied.

Mixing is a critical phase in many processes, which may consume a lot of time and energy and make use of costly equipment. Radiotracer applications are ideally suited to determine optimum time needed for adequate mixing of components in process vessels. For example, insertion of radionuclide in melting furnaces makes it possible to check the influence of mixing and of turbulence on the speed with which homogeneity is achieved. In order to estimate the extent of mixing, isotopes are introduced into the molten metal and simultaneous readings are taken at frequent intervals at all the furnace openings. The metal is then poured into identical moulds to form samples, and the degree of homogeneity can be ascertained.

V. Wear and Corrosion

The oldest industrial application of radioisotopes predates World War II, when a patent was issued covering the use of radioactive isotopes for measuring friction wear. At that time, the tracer material was plated onto the surface of the object to be tested. Wear was then calculated on the basis of amount of radioactivity worn off the plated surface or on the amount of radioactivity transferred to the surface against which the test specimen was worn. Subsequently, tracer techniques for measuring wear have expanded greatly.

Since early sixties, BARC, DAE, has made pioneering contribution towards the development and promotion of radiotracer technology in India and Asia Pacific region for trouble-shooting and process optimization in industry. BARC has so far carried out more than 500 field-scale radiotracer investigations to benefit the Indian industry, be it steel and oil industries, petroleum refineries or chemical industries.

Role of BRIT in providing Isotope Application Services to Industries

Isotope Application Services (IAS) of BRIT, DAE, involve sealed source and radiotracer application in various process industries, especially in petroleum refineries, to pinpoint the cause

of malfunctions in plant equipment such as distillation columns, cyclones, heat exchangers, pipelines, tanks, separators, etc. These applications are very helpful to take decisions regarding shutdown and maintenance, which reduces plant downtime. It provides great economic benefits to the industries as well as BRIT to earn revenue.

BRIT started Isotope Application Services (IAS) in 2007 on commercial basis. However, research activities related to industrial application of sealed sources and radiotracer are carried out by BARC. Being the most popular activity among industries, gamma scanning was the main focus. For the first time in India, manual scanning of columns was replaced by fully automatic gamma scanning machine, which enhances the performance drastically. Around 180 columns have been scanned at various refineries of India. As per the demand, radiotracer applications, radiometry, pipe scanning and other relevant jobs were added to the profile.

BRIT primarily deals with the gamma scanning of process columns, identification of leaky heat exchangers, radiometry of radiation shielding objects and pipe scanning. Indigenously developed fully automatic gamma scanner and compact multi-channel data acquisition system is being used for column scanning and radiotracer studies, respectively. In-house development of organic ^{99}Mo as radiotracer provided higher accuracy, faster service delivery and safer handling. As the environmental safety norms have become stringent, radiotracer studies for fly-ash disposal into the open mine voids have been carried out for thermal power plants since last few years. Tritium injection for oil field analysis has been done and future injections are also planned.

Isotope application techniques are getting more popular now a days in India. Due to increasing demand and to meet customer requirements in the competitive market, it is intended to continue R&D for machineries and equipment development based on cutting edge technology. These developments will improve the quality of services provided to the clients so that they can

Table 3: Examples of benefits resulted to Indian Industry with Radiotracer Applications

| Application | Savings / Benefits |
|--|--|
| Gamma scanning of industrial process columns | <ul style="list-style-type: none"> - ~ Rs 6 crore for a typical small gamma scanning columns - Shutdown time reduced - Pinpointing of the problem area |
| Leak location in underground pipelines | <ul style="list-style-type: none"> - ~ Rs.18 crore for a typical 50 km long petroleum product pipeline - No need to dig open the suspected section of the pipeline - Pin pointing the leak location |
| Blockage location in underground pipelines | <ul style="list-style-type: none"> - Rs. 80 lakhs for a typical 50 km long pipeline - Reduced down time of the pipeline - Accuracy in locating |
| Studies for dead volume estimation in chemical reactors 3 m diameter reactor | <ul style="list-style-type: none"> - Rs. 105 crore per year - Reduction in shut-down period |
| Mercury inventory in caustic soda cells | <ul style="list-style-type: none"> - Rs. 75 lakhs/ month for a plant having about 50 electrolytic cells. - No plant shutdown is required - Handling of mercury for inventory is completely avoided. |

take critical decisions with more confidence. More value-added services such as previous reports access, on-site interpretations, offering signature scanning, etc. will be provided. It is also planned to launch new marketing campaigns like use of social media to reach and spread awareness among target clients. It is intended to penetrate other chemical industries, heavy engineering units, thermal power plants and oil & gas sector in apart from petroleum refineries.

Important applications of tracer technology, resulting in vast economic benefits are summarized in Table 2.

Conclusion

Evaluation and identification of use of radioisotopes and radiation technology in medical, industrial and research sector is a rapidly growing requirement. Techniques involving radioisotopes and radiation technology have been widely applied in various fields of industry. This is possible because of the properties of radioisotopes, i.e., it can selectively label certain process media and represent their movements and/or pathways, or the ability to reveal much of the inner details while its transmission and attenuation or its ability to deposit radiation energy at the desired location inside the exposed matter to reveal physical, chemical and biological changes.

Applications of radioisotopes and radiation technology in medicine, industry, food, agriculture and research, constitute some of the important beneficial effects of peaceful uses of atomic energy. Development of appropriate techniques and technologies for production and applications of radioisotopes is an ongoing process. Unlike many other advanced technologies, isotope applications have a low gestation period. A technology developed in the laboratory is often successfully applied in field within very short time period. This makes the isotope technology one of the highly visible peaceful uses of nuclear research. The Indian industry has been one of the early beneficiaries of indigenous isotope techniques and processes. Concerted efforts at the Bhabha Atomic Research Centre (BARC) and the Board of Radiation & Isotope Technology (BRIT) are helping in production of sources of radiation and spreading the applications of radioisotopes for Industrial processing, non-destructive testing, trouble shooting in processing plants and for designing and commissioning of new plants, followed by deployment of such technologies. Department of Atomic Energy (DAE) is constantly trying to reach the production as well as user agencies for wider deployment of such technologies, so as to provide larger benefits to society.

References

1. Indian Association of Nuclear Chemists and Allied Scientists (IANCAS) Publications <https://www.iancas.org.in>
2. Industrial Applications of Radioisotopes and Radiation <http://docplayer.net/42486286-Industrial-applications-of-radioisotopes-and-radiation.html>
3. Board of Radiation & Isotope Technology (BRIT) <https://www.britatom.gov.in>
4. Bhabha Atomic Research Centre (BARC) <https://www.barc.gov.in>