

**GOVERNMENT OF INDIA
BHABHA ATOMIC RESEARCH CENTRE
Nuclear Recycle Group
Technology Development Division**



भारता परमाणु अनुसंधान केंद्र
BHABHA ATOMIC RESEARCH CENTRE

Ref: TDD/DSS/APR22/OPA/38012

Date: 20 /04 /2022

Notice Inviting Tender (Minor Fabrication)

Sealed quotations are invited for and on behalf of the President of India by Head, Technology Development Division for the following work from the contractors having adequate similar experience, staff with valid PVC, meeting the vendor evaluation criteria and who have similar experience with different units of DAE, Government Organizations, Public Sector Undertakings, reputed public/private organizations etc.

Description of work	Duration
Fabrication, trials, testing & supply of Glove Bags & high containment crimping tool kit.	2 Calendar month

The due date of <u>receipt of sealed quotation</u> :-	<u>05/05/2022 up to 15:00 hrs</u>
The sealed quotation will be opened on:-	<u>Next working Day of due date.</u>

1. **Vendor Evaluation Criteria:-**

The vendor shall give following **undertaking along with the bids. Else the offer is likely to be rejected.**

Undertaking: The vendor shall give undertaking stating that he has understood the entire scope of work and he will complete the entire work as per BOQ in time as per the completion period of the work order.

2. BARC reserves right to reject any or all tenders/applications without assigning any reason thereof.
3. **Validity of offer must be minimum 3 months.**
4. **COVID related guidelines applicable to the contractor for the site works at BARC as published on BARC website or as issued by Engineer in Charge shall be scrupulously followed during the execution of work.**
5. The work shall be completed within **02 Calendar months** from the date of issue of the work order.
6. Any deviation from specification shall be clearly mentioned in your offer.
7. The quotation shall be printed only on letter head and GST number as well as any other prevailing Tax Registration Number registered with local, state/Central authority, PAN Number of the firm, Service Tax Registration Number etc should be mentioned on it.
8. Quotations that are received in computer generated form are to be construed as **invalid and will be rejected.**
9. **It may please be noted that BARC has been declared as R&D organization and concessional rate of GST is applicable. Necessary exemption certificate will be made available to successful vendor.**
10. Income tax at prevailing rate at the time of execution of work and applicable surcharge on Income Tax as applicable & education cess on IT & SC as applicable will be deducted from the bill. **Tax as applicable on GST will also be deducted from bill.**
11. Similarly claims raised by the firms are also to be in Printed Invoice formats consisting of the above Registration Numbers.
12. It is necessary to mention Taxes Registration Numbers clearly in the quotation, without which the offers will not be considered.
13. The enquiries should be sent only by **Speed post/Registered Post** through Indian Postal Service and should be addressed to:

Devendra Sandhanshive, Scientific Officer-G

Room No. 315, CDCFT Building, Near WIP,
Technology Development Division, Nuclear Recycle Group
Bhabha Atomic Research Centre, Trombay, Mumbai-400085

14. **The following information should be written on the sealed offer:**
Our Enquiry no., Subject, Due Date & Sender's full address.
15. **The bids sent by any other mode (e.g. manual, courier etc) shall be rejected without assigning any reasons as per terms and conditions of Accounts, BARC.**
16. **Only those Vendors quoting for all the works mentioned as per the enclosed BOQ will only be considered. Part offer will be rejected.**
17. **Offers will be evaluated on overall cost basis hence it is mandatory for bidder to consider entire work and quote accordingly.**
18. **The Payment will be made as per Government procedure after the job is completed satisfactorily** in all respects and has been approved by the officer supervising the job. Payment shall be made only on satisfactory completion of work, removal of debris/waste arising out of the work carried out from site and on production of bill in duplicate, advance stamped receipt, guarantee / warranty certificates, stores receiving voucher duly signed by ASO (if applicable), No Demand Certificate from Security. In general after submission of all the papers mentioned in work order, it takes about few weeks period for releasing the payment.

Devendra Sandhanshive
SO/G, TDD,
NRG, BARC
Ph. no. 022-25591279
022-25595507 (TDD office)

Technical Specification

1. **Title:-** Fabrication, trials, testing & supply of Glove Bags & high containment crimping tool kit as per following technical specification and bill of quantity.
2. **Scope of Work:-**
 - 2.1 Fabrication, trials, testing & supply of Glove Bags as per scope drawing. (Qty:- 15 Nos)
 - 2.2 Fabrication & supply of ambidextrous short hand Gloves made of natural rubber raw material or other suitable material. Thickness of glove should be 0.6 mm. Each glove shall have 4-5mm thick O ring sealed at open end of the glove. (Qty:- 20 Pairs)
 - 2.3 Fabrication and supply of high containment crimping tool kit. (Qty:- 1 Set)
Tool kit consists of following:-
 - Special purpose crimping tool gun suitable for installing a pair of PVC crimps on glove bags containment. (Qty: - 1 No.).
 - Special purpose Cutter tool for cutting glove bags for creating two separate containments. The cutting shall be done through a narrow gap between the pair of PVC crimps installed on the glove bag. (Qty: - 1 No.)

Note:-The cut/separated Glove bag installed with PVC crimp should qualify containment criteria of less than level 5 of Occupational Exposure Band (OEB) i.e. less than $1 \mu\text{gm}/\text{m}^3$ Occupational Exposure Limit.

 - 2.4 Supply of high containment PVC crimps (Qty: - 100 No.) qualifying for containment criteria of less than level 5 of Occupational Exposure Band (OEB) i.e. less than $1 \mu\text{gm}/\text{m}^3$ Occupational Exposure Limit (OEL). **Necessary certificate that the crimps are meeting this OEB/OEL criteria shall be provided.**
3. **Trials, Testing & Inspection :-**

Following testing, trials and inspection will be carried out.

 - ✓ **Handling Trials in one sample Glove bag:** - Initially the firm should fabricate one trial glove bag as per scope drawing. Then the bag will be installed on a temporary set up at the vendor's work shop and handling trials will be carried out. Suitable modifications shall be done in the design of glove bag till satisfactory performance is achieved. Then remaining glove bags shall be taken up for fabrication after approval of engineer in charge.
 - ✓ Visual inspection of all the glove bags will be carried out the purchaser.
 - ✓ **Pressure Testing of 2 sample glove bags for leak tightness checking:** - Pressure Testing of Glove bags shall be done at 3-5mm of Water column to identify leaking areas if any. Acceptance criterion for Pressure Testing is that the containment should hold 3mm of Water Column (positive pressure) for 15 min. Leak testing shall be witnessed by purchaser.
 - ✓ The firm should demonstrate trials of crimping tool gun & cutter to the purchaser.
4. **Packing, Transportation & Delivery :-** - After satisfactory inspection and trials at supplier workshop, all the items shall be supplied to WMZ store BARC, Trombay after written consent of Engineer in Charge. Supplier should take due care for packing of the components in order to avoid damage during transportation & handling.
5. **Guarantee:-** The supplier shall guarantee that the goods supplied by him are new, of required quality and in full accordance with the requirements of the specifications and drawings. The supplier shall provide the warrantee that the goods are free from defects in design, material and workmanship. The warrantee shall cover for a period of twelve (12) months from the date of handing over the items to the purchaser. If within this warrantee period, the goods or any part thereof are found defective because of workmanship or materials, the supplier shall at his own expense, repair or replace the parts. The guarantee period for the replaced parts or repaired works shall be twelve (12) months after repair or replacement.

Annexure-A-Bill of Quantities

Title of Work: - Fabrication, trials, testing & supply of Glove Bags and high containment crimping tool kit.

Sr. No	Description of Work	Unit	Qty.	Rate Rs.	Amount Rs.
1	Fabrication, trials, testing & supply of Glove Bags as per scope drawing.	15 Nos.			
2	Fabrication & supply of ambidextrous short hand Gloves made of Natural rubber raw material or other suitable material. Thickness of glove should be 0.6 mm. Each glove shall have 4-5mm thick O ring sealed at open end of the glove.	20 pairs			
3	Fabrication and supply of high containment crimping tool kit. Tool kit consist of following:- ✓ Special purpose crimping tool gun suitable for installing a pair of PVC crimps on glove bags containment. (Qty 1 No). ✓ Special purpose Cutter tool for cutting glove bags for creating two separate containments. The cutting shall be done through a narrow gap between the pair of PVC crimps installed on the glove bag. (Qty 1 No) Note:- The cut/separated Glove bag installed with PVC crimp should qualify containment criteria of less than level 5 of Occupational Exposure Band (OEB) i.e. less than 1 $\mu\text{gm}/\text{m}^3$ Occupational Exposure Limit.	1 set			
4	Supply of high containment PVC crimps qualifying for containment criteria of less than level 5 of Occupational Exposure Band (OEB) i.e. less than 1 $\mu\text{gm}/\text{m}^3$ Occupational Exposure Limit.	100 Nos.			
5	Basic Total Cost in Rupees				
6	Concessional GST at 5%. <u>Note:-Necessary GST exemption certificate will be made available to successful vendor.</u>				
7	Grand Total Cost (In words:- Rupees _____)				

Signature & Seal of the Firm

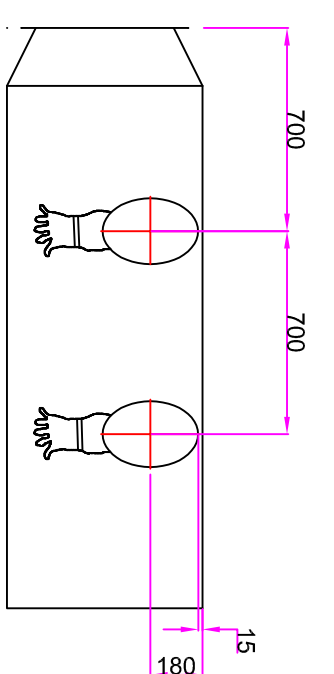
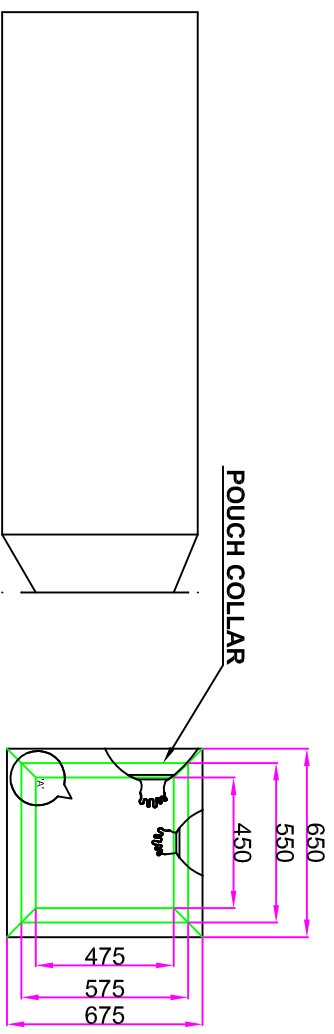
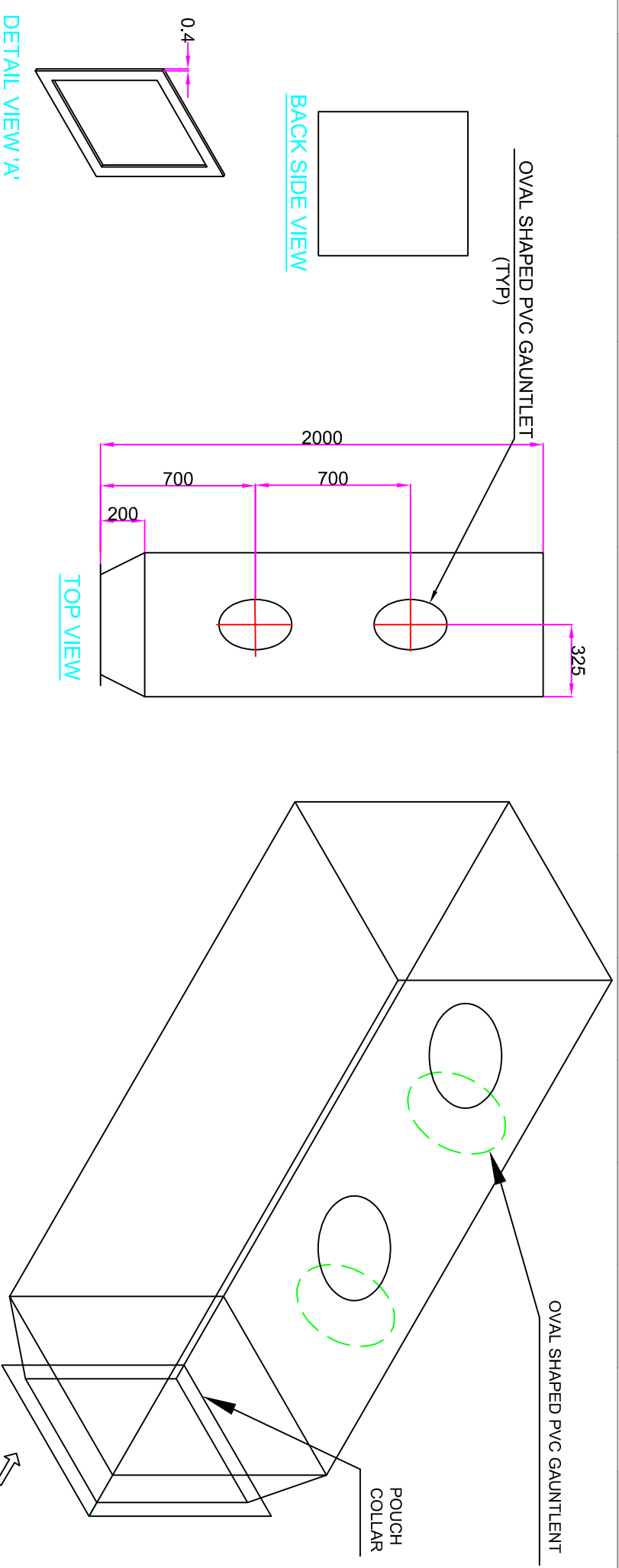

MATL: FLEXIBLE PVC, 0.4 MM THK

GOVERNMENT OF INDIA
BHABHA ATOMIC RESEARCH CENTRE
 TECHNOLOGY DEVELOPMENT DIVISION

TITLE :- GLOVE TENT

PROJECTION		DRG. NO.	SCALE
DRAWN		APP'D	NOT TO SCALE
DRG. CHD.			
DESIGN			
DESIGN CHD.			
		PROJECT	

NOTE:- ALL DIMENSIONS ARE IN MM.