

**Government of India
Bhabha Atomic Research Centre
Laser & Plasma Technology Division**

Trombay
Mumbai - 400 085.

REF: BTDG/ATLAF/BD/2021/23975

Date: 14/12/2021

Notice Inviting Tenders

To : All parties
Sub : Fabrication of Atomic beam generator

DUE DATE: 24/12/2021

Dear Sirs,

1. Quotations are invited for the minor fabrication job as per the enclosed specifications. Taxes and excise duties shall be quoted separately. PAN number and GST number of the party must be mentioned in the quotation.
2. The quotations must reach Head, Laser & Plasma Technology Division by the due date as above and must be sent in a sealed envelope *superscribed with the above reference number and due date given above*. Quotations must be sent by registered/speed post through Indian postal services.
3. The address on the envelope should read
Attn. Dr B Dikshit: Fabrication of Atomic beam generator
To
The Head,
Laser & Plasma Technology Division.
Modular Lab., BARC, Mumbai - 400 085.
4. The bidder shall get the job approved by our engineer and complete the work order within 3 months from the date of issue of work order.
5. Head, Laser & Plasma Technology Division, BARC reserves the right to accept or reject any or all quotations without assigning any reason.

Yours faithfully.

B. Dikshit
24/12/2021

Dr B Dikshit
SO/H, L&PTD

Dr. B. DIKSHIT
Scientific Officer (H)
Head, RIS Engineering Section
ATLAF, BTDG
BARC, Mumbai - 400 085.

Encl: Detailed Technical Specification (Annexure-1)

Copy to:

- 1) BARC site (Hall-6)
- 2) SIRD (for uploading in BARC website)
- 3) V S Bhavan notice board

General Specifications

1.0 Free issue materials :- No free issue materials

2.0 Quality surveillance, inspection and inspection report

2.1 All work covered by the specification shall be subject to quality surveillance by the purchaser or his authorized representative for which purpose the fabricator shall allow access at all reasonable time during manufacture to

2.1.1 The premises in which the work is being carried out.

2.1.2 The drawing and/or tooling involved.

2.1.3 Gauge instruments, etc. required for inspecting the work.

2.2 Inspection and tests shall be carried out by the fabricator as per the requirements detailed in the drawings and these specifications.

2.3 Components found unsatisfactory as to workmanship or material shall be removed by fabricator and replaced by components, which are satisfactory.

3.0 Delivery

The bidder shall deliver the finished components after approval by our engineer within 3 months from the date the purchase order is issued to bidder.

4.0 Subcontract

4.1 The fabricator shall not sub-contract any or all the work without written consent from the purchaser, The Fabricator shall be responsible to the purchaser for all work of the sub-contractor of the fabricator, if allowed by the purchaser.

5.0 Tax

5.1 H form will be issued if necessary.

Income Tax @ 2% will be deducted from your bill for an amount > Rs. 20,000/.

Guarantee certificate/warranty certificate may be forwarded along with the bills.

Payment: Payment shall be made only on satisfactory completion of work and on production of bill, advance stamped receipt and guarantee / warranty certificate.

Annexure-1

Fabrication of Atomic beam generator

SI No.	Specification	Material	Quantity
1	Fabrication and supply of Atomic beam generator having following components - a) Crucible for evaporation as per drawing No: BTDG/112021/1 b) Collimator for atomic beam as per drawing No: BTDG/112021/2	Tantalum (purity of 99.9% or more)	1 No.

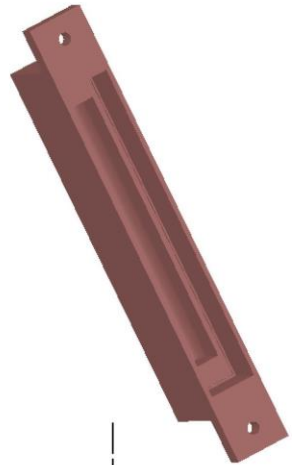
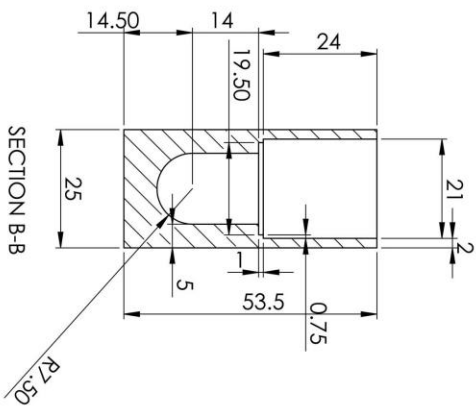
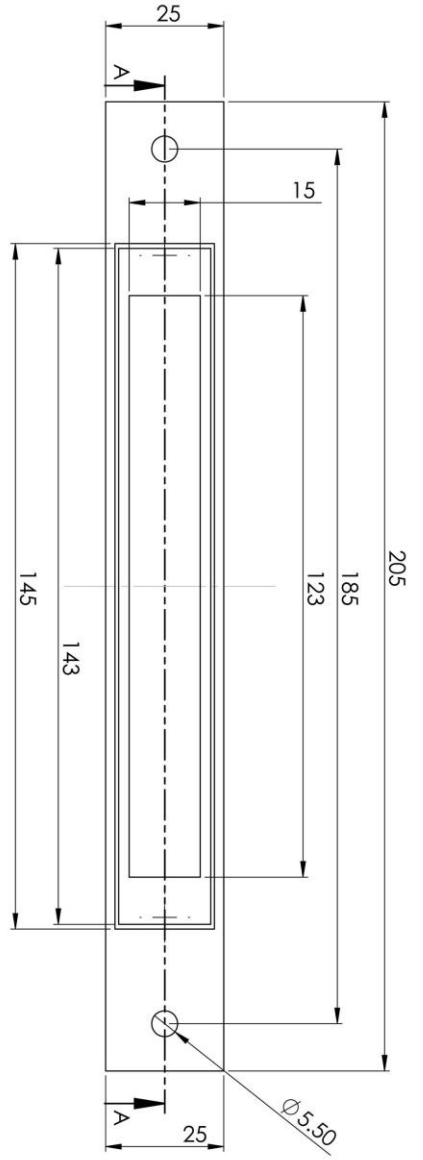
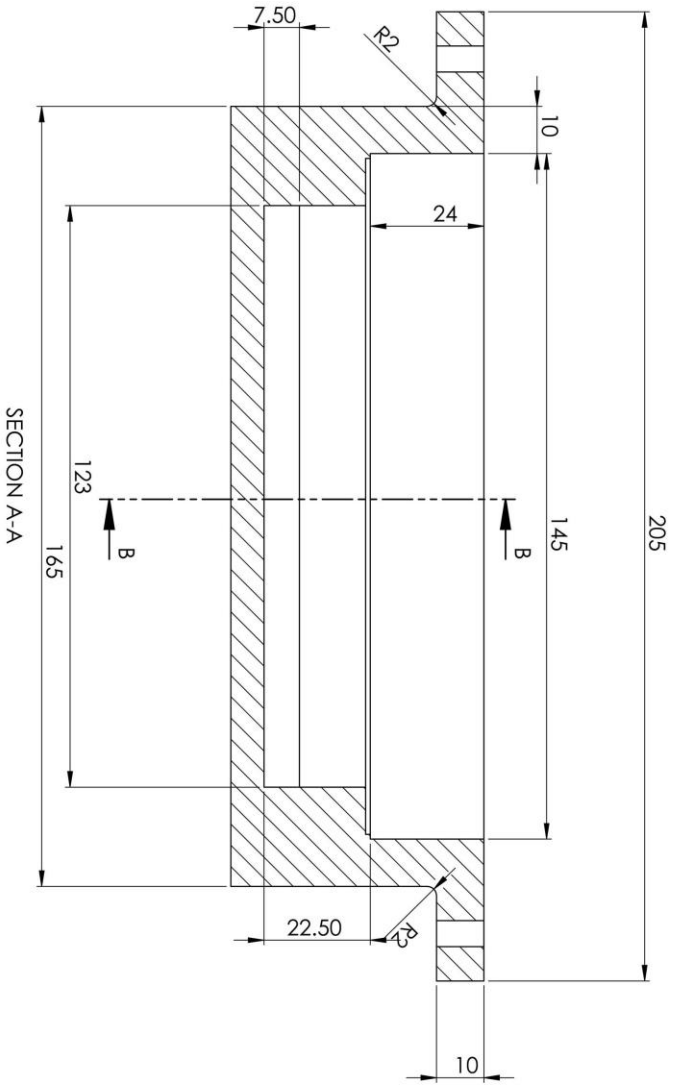

Name: Crucible
 DRWG. NO.- BTDG/112021/1

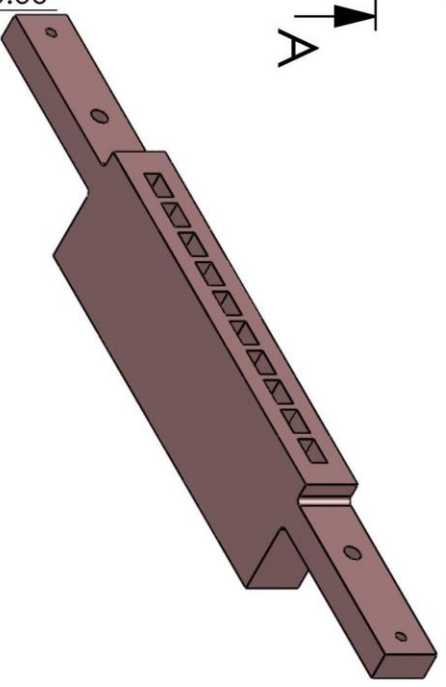
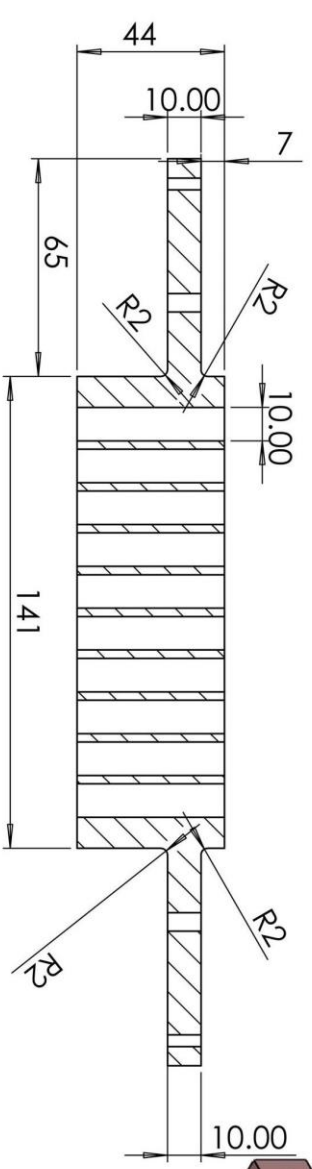
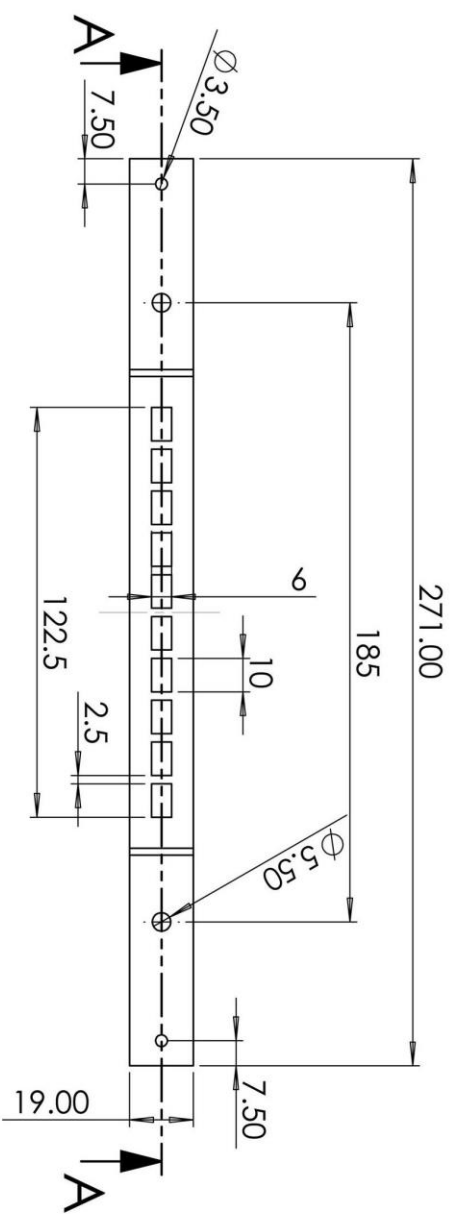

NAME- COLLIMATOR
 Drawng. NO.-BTDG/112021/2

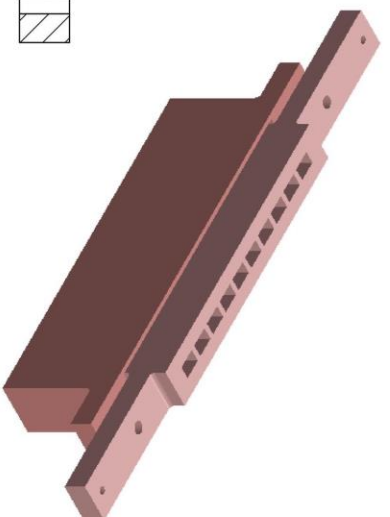
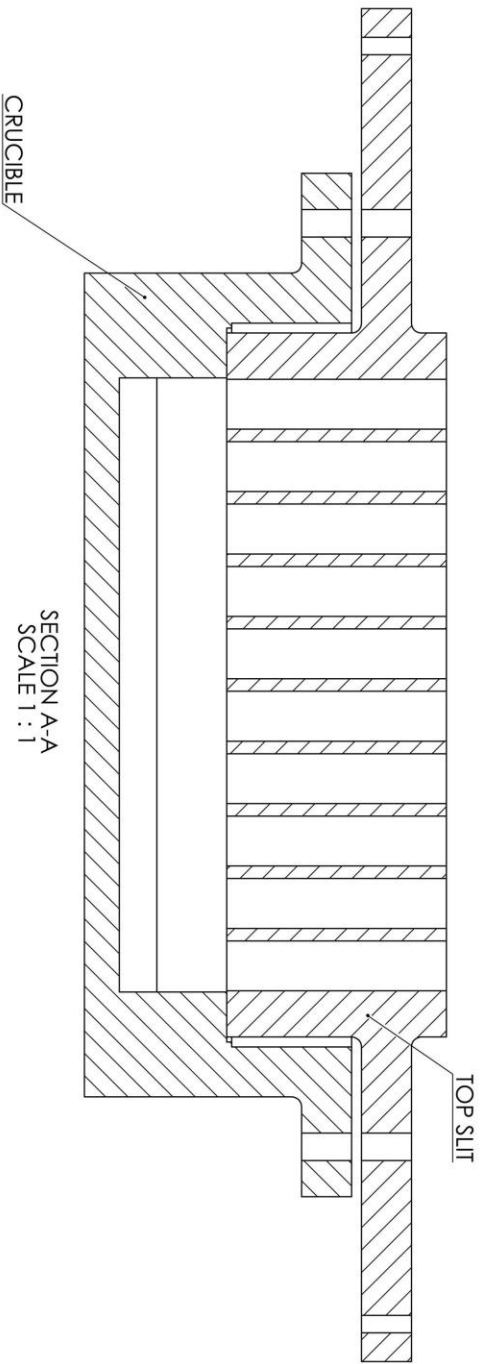
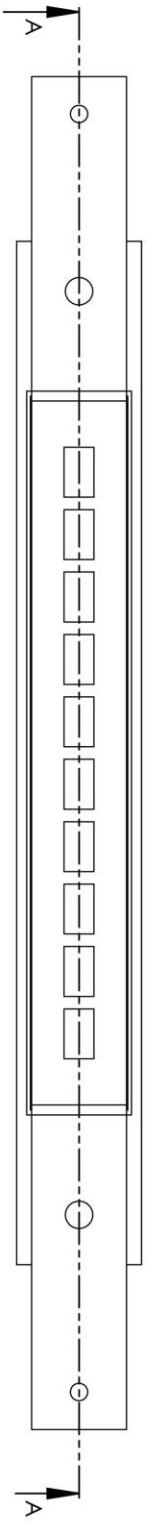

Crucible Assembly