

Government of India  
Bhabha Atomic Research Center  
Energetics & Electromagnetics Division

Reference: BARCV/PP&EMD/2021-22/R&D-44/WO/SM/57

Date: 15/11/2021

Name of Party:

**SUB: Fabrication and supply of EM-Shapers as per attached drawing. (Details of specifications and drawing attached)**

Dear Sir,

1. Quotations are invited for the minor fabrication job, as per the enclosed sketches
2. Bidder shall quotes for fabrication of these components with materials.
3. Taxes shall be quoted separately.
4. The quotation must reach the Head, Pulsed Power & Electromagnetics Division by date **23/11/2021;04:00pm** and must be sent in a sealed, printed envelope superscripted with reference number and the due date given above.
5. The address of the envelop should read –

Head  
Pulsed Power and Electromagnetics Division (PP&EMD)  
PEB-1, Gandivanipalem,  
Dossuru Panchayat, Atchutapuram Mandal,  
Bhabha Atomic Research Centre (BARC),  
Visakhapatnam-531011  
(Attention: Dr. Archana Sharma/Shobhna Mishra)  
Contact No. 0891-2832022(O)

1. The fabrication work shall be subjected to inspection by our Engineer. The finished component shall not be dispatched prior to approval of our engineer at bidders premises. Necessary inspection facilities should be provided to our engineer during fabrication at bidders premises.
2. The bidder shall deliver the finished components after approval by our engineer within 4/6 weeks from the date of firm work order issued to the bidder. The finished components along with left over material shall be delivered by the bidder at the address mention in point no. 5.
3. Head, PP&EMD reserves the rights to accept/ reject any or all quotations without assigning any reasons.
4. Delivery charges if any, must be clearly mentioned within the offer.
5. Quotation must also indicate the validity of offer starting from the due date.
6. Drawing / sketches must be returned along with the offer.
7. Quotation is to be in printed letter-head / quotation format only. Quotation received in computer-generated forms will be considered as invalid and rejected.
8. Quotation should consists of Sales Tax registration number (Registered with local ST / CST authority), GSTIN No., PAN number of the firm, services tax registration number etc.
9. Claim preferred by the firms are also to be in printed INVOICE format consisting of the above registration numbers.
10. No Free issue material will be given.

  
15-11-2021  
डॉ. (श्रीमती) अर्चना शर्मा / ARCHANA SHARMA  
निदेशक / Director  
किरणपुंज प्रौद्योगिकी विकास वर्ग  
Beam Technology Development Group  
भारत सरकार / Government of India,  
भा.प.अ. केंद्र / B. A. R.C.  
पॉम्बे, मुंबई / Trombay, Mumbai - 400 085.

(Dr. Archana Sharma)  
GD, BTDG  
Head, PP&EMD  
BARC, Visakhapatnam - 531011

**Reference:** BARCV/PP&EMD/2021-22/R&D-44/WO/SM/57

**Specification:** *Fabrication and supply of EM-Shapers as per attached drawing and specifications.*

**Quantity:** 80 No.s

**Description:**

- 1) Material: Copper-ETP

**NOTE:**

**The following points must be taken care of, or else item will not be accepted.**

- 1) The item should be fabricated as per drawing attached (Annexure-I).
- 2) **Electrical Discharge Machining (EDM)** process is to be used for the 0.5 mm slit cutting along the shaper for 70 mm, as indicated in the drawing. The items have to be delivered within 5 weeks at the user's site, i.e **Pulsed Power & Electromagnetics Division (PP&EMD), Bhabha Atomic Research Centre (BARC), Visakhapatnam- 531011.**
- 3) Tolerance on drawing dimensions allowed is  $\pm 1\%$  except for slit. Slit being a critical dimension,  $\pm 100$  micron tolerance is allowed. Any fault or deviation in item from detailed drawing will not be accepted. In case found, the party must take the items from user's site to its place and provide a fresh piece against the faulty piece.
- 4) Party must first supply 01 No. of the fabricated item and ensure the dimensional compatibility of the item to our existing system at BARC (V)-Atchutapuram. If compatibility is achieved party can then fabricate the rest no.s and supply the same within the delivery period as will be mentioned within work order. Minor modifications must be incorporated by the party without extra cost. At time of supply of items party has to confirm compatibility check on existing system of all the pieces at BARC(V) site, in case any defect found in any piece party must replace the defective piece with a new one.
- 5) The items have to be supplied at **PEB-1, Pulsed Power & Electromagnetics Division (PP&EMD), Bhabha Atomic Research Centre (BARC) , Gandivanipallem village, Dossuru Panchayat, Atchutapuram Mandal, Visakhapatnam- 531011** ensuring proper packaging before dispatch.

2

1

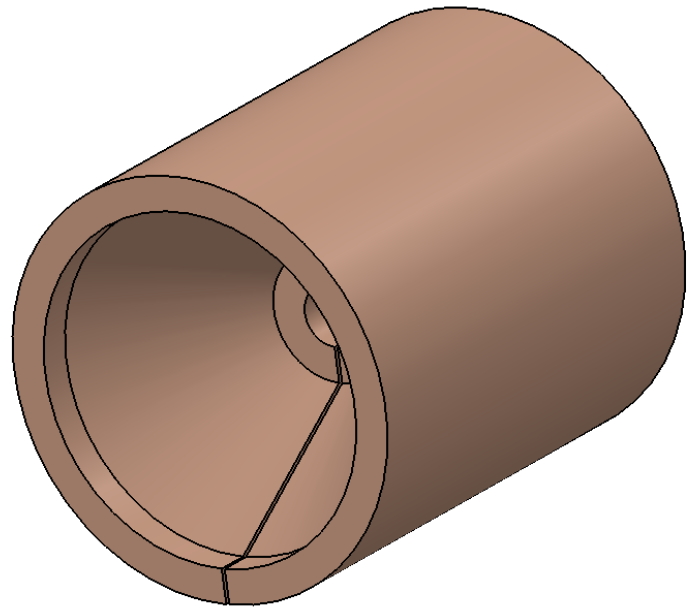
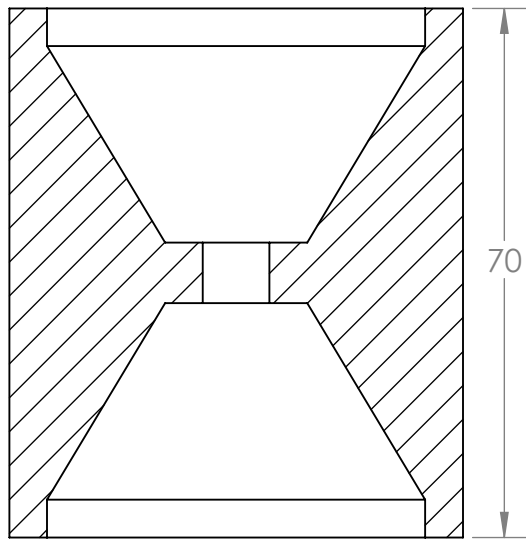
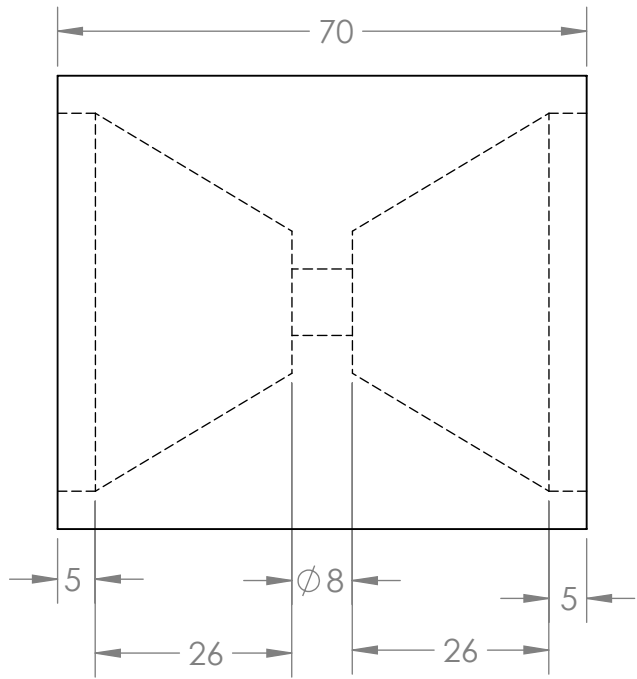
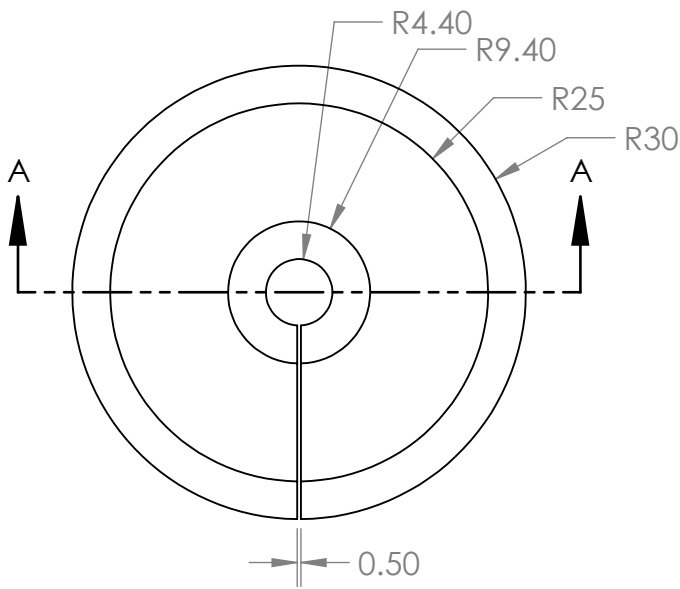

SECTION A-A  
SCALE 1 : 1

All dimensions in mm

**PROPRIETARY AND CONFIDENTIAL**  
THE INFORMATION CONTAINED IN THIS DRAWING IS THE SOLE PROPERTY OF <COMPANY NAME >. ANY REPRODUCTION IN PART OR AS A WHOLE WITHOUT THE WRITTEN PERMISSION OF <COMPANY NAME> IS PROHIBITED.

			DIMENSIONS ARE IN INCHES TOLERANCES: FRACTIONAL ± ANGULAR: MACH ± BEND ± TWO PLACE DECIMAL ± THREE PLACE DECIMAL ±	NAME	DATE
			MATERIAL	DRAWN	
			FINISH	CHECKED	
NEXT ASSY	USED ON			ENG APPR.	
				MFG APPR.	
				Q.A.	
				COMMENTS:	
APPLICATION			DO NOT SCALE DRAWING		

**Item : SHAPER**  
**Material: Copper**

SIZE <b>A</b>	DWG. NO. shaper	REV.
SCALE:1:2	WEIGHT:	SHEET 1 OF 1

2

1

B

B

A

A