

Government of India
Bhabha Atomic Research Centre
Electromagnetic Application & Instrumentation Division

Ref : EmA&ID/RKB/2021/

Date: 12 -11-2021

Sub: Fabrication of Special Purpose Precision Rack Assembly for indigenous SIMS- along with all accessories affixed properly as per the attached drawing & specifications

Dear Sir/Madam,

1. Quotations are invited for the above said confirming to scope, drawings and technical specifications listed in the **Annexure A1**
2. Bidder shall quote for deliverables as per technical specifications.
3. Free Issue material is not involved. .
4. Taxes and Excise Duties shall be quoted separately. Form AF / H whichever is applicable shall be provided, if required.
5. **The quotation must reach The Head, Electromagnetic Application & Instrumentation Division by 26/11/2021(Noon) and must be sent in a sealed envelope super scribed with the reference number & the due date given above. Courier are not allowed in BARC premises, the quotation shall be sent by speed post/registered post.**
6. The address on the envelop should read:

The Head,
Electromagnetic Application & Instrumentation Division
Physics Group
BARC, Trombay,
Mumbai - 400 085.
(Kind Attn: R.K.BHATIA, SO/G, AMSS/EmA&ID)
7. The bidder shall complete the job within 16 weeks from the date of firm work order issued to the bidder. The finished components shall be delivered by the bidder at **EmA&ID, BARC, Trombay, Mumbai - 400 085.**
8. Head, EmA&ID reserves the rights to accept / reject any or all quotations without assigning any reason.
9. Delivery charges if any must be clearly mentioned in the offer. Quotation must also indicate the validity of offer. Quotation must also indicate the GST no and PAN no of the party.
10. Drawings / Sketches must be returned along with the offer.
11. The quotation has to be signed by authorized person with company seal.
12. Payment will be made only after satisfactory completion of work on production of bill, delivery challan and advance stamped receipt.

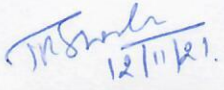
R.K.BHATIA
SO/G, AMSS/EmA&ID
BARC

Annexure A1

Ref : **EmA&ID/RKB/2021/ P-13901**

Date: **12 -11-2021**

Fabrication of Special Purpose Precision Rack Assembly for indigenous SIMS- along with all accessories affixed properly as per following specifications and drawings.

S.No.	Item particulars	Qty.
01.	Special Purpose Precision Rack Assembly as per drawing No. SIMS/2021-01 and other details given below the table. Accessories: a. Card Frames as per details given in Annexure A2 b. MAGNET MOUNTING Stainless Steel 304 made TROLLEY as per Drawing no. MT-3090-03/04/18 and other details given in Annexure A3	1 set

Item: Special purpose Precision Rack Assembly with dimensions and other technical details as per Drawing no. **SIMS-2021/01**

The top plate with cut put as per drawing (Ground finish)

Frame: 40 mm heavy duty square tubes with reinforcement (Powder coated MS)

IS 13871: Powder Coatings color (off white panels with navy blue frame paint)

The space under the table will be made compatible for placing 19" Standard Anodized Aluminum Card frames of different sizes as per our drawing and specifications along with its mounting accessories including vertical slotted members and horizontal support angles.

Specification of card frames is given separately in Annexure A2

Blank panels - Panels are of 14 SWG (2.0mm) Anodized aluminum

SUPRT ANGLS, HVY DTY 475mmD

Rapid assembly and easy accessibility

Side Panels and rear panels of Rack are provided with "Half Shears" or lowers with ventilation slots with hinge/lock arrangement allows the panel to open

Card frames used will be S20 2U/3U/4UAND 5U84T/465 mm (Extra depth)

Cable duct required: STD 2 Inch high quality Plastic with closing caps.

Electrical Earthling required: nickel plated copper bus bars with both horizontal & vertical fittings with tapped holes for connection (2 inch pitch)

Powder coated 6 mm plate may affixed on bottom for mounting transformers.

IS 13871: Powder Coatings colour (off white panels with navy blue frame paint)

Table top: 8 mm thick S.S 304 with ground finish less than 0.8 microns RMS (surface grinding is a must)

Level finish: accuracy up to 10 microns horizontal plane. (Including Flatness)

Vibration isolator: should be affixed with the bottom part of Jacks (also square cushion rubber sheet should be provided separately)

Heavy duty S.S Jacks: 6 nos. (Load carrying capacity of each wheel should be 1/2 ton (500 Kg or above)

Heavy duty wheels: 4 nos. Load carrying capacity of each wheel should be 1/2 ton (500) or more

Power input: PDU 19" Octagonal Socket 6 x 5/15 Amp with 16 Amp MCB and Indicator with 3mtr Cable and 3 Pin Plug provided on inside the table (2 sets on each column)

Load testing: deflection test should be carried out for 2 Ton Concentrated load at Centre of the Rack Table (Deflection at centre should be within the allowable limit)

R.K. Bhatia
12/11/21

R.K.BHATIA
SO/G, AMSS/EmA&ID
BARC

Annexure A2

Card Frames

Item Description:

19" Standard Anodized Aluminum Card frames of different sizes along with its mounting accessories as per the following specifications & quantities given below.

General specifications & Material and Finish & features.

Side Panels are of 14 SWG (2.0mm) aluminum. The two front profiles (82-42XX) have a 3.00mm extension. Rear profiles (82-44XX) are suitable for direct mounting of Motherboards without necessity of Insulation Spacers Front & Rear Panels are made of 2.5mm thick aluminium sheets Top and Bottom Covers can be supplied with a natural anodized finish.

Rapid assembly and easy accessibility

Side Panels are provided with "Half Shears"

Top and bottom covers - plain or with ventilation slots.

Front & Rear panels - Screw-on type or hinged to open either downwards or sideways

The hinge arrangement allows the panel to open

180 degree and remain clear of the adjacent profile.

Additional specifications;

The material used for card frame should be highest standard ie.:- 1S Grade and Alu Extrusion of E18 Grade with chemical composition of Alu 99%.

The anodizing process should follow 11 tank procedure.

(Dimensional details and quantity required are given below)

Card frame with following specification

1. S20 2U/84T/465 mmD (extra depth)

Front Panel, Rear Panel blank, Base Plate/2mm thick Intermediate Profile (pair) PNL, S20
FRNT HNG-DW 2U/84T/2.5mm (1Nos.)PNL, S20 REAR SCR-ON 2U/84T/2.5mm (1Nos.)
HANDLE PULLOUT 2U UNIVERSAL NATURAL (PAIR) T/B COVERS
84T/465/0.9mm SLT/ANZD (PAIR) BARS for C-Frame Support (PAIR) Length: 285 mm

Qty: 3 nos.

2. S20 3U/84T/465 mmD (extra depth)

Front Panel, Rear Panel blank, Base Plate/2mm thick Intermediate Profile (pair) PNL, S20
FRNT HNG-DW 3U/84T/2.5mm (1Nos.)PNL, S20 REAR SCR-ON 2U/84T/2.5mm (1Nos.)
HANDLE PULLOUT 2U UNIVERSAL NATURAL (PAIR) T/B COVERS
84T/465/0.9mm SLT/ANZD (PAIR) BARS for C-Frame Support (PAIR) Length: 285 mm

Qty: 5 nos.

3. S20 3U/84T/400 mmD (normal depth)

Front Panel, Rear Panel blank, Base Plate/2mm thick Intermediate Profile (pair) PNL, S20 FRNT HNG-DW 3U/84T/2.5mm (1Nos.)PNL, S20 REAR SCR-ON 2U/84T/2.5mm (1Nos.) HANDLE PULLOUT 2U UNIVERSAL NATURAL (PAIR) T/B COVERS 84T/400/0.9mm SLT/ANZD (PAIR) BARS for C-Frame Support (PAIR) Length: 285 mm

Qty: 2 nos.

4. S20 4U/84T/465 mmD (extra depth)

Front Panel, Rear Panel blank, Base Plate/2mm thick Intermediate Profile (pair) PNL, S20 FRNT HNG-DW 3U/84T/2.5mm (1Nos.)PNL, S20 REAR SCR-ON 2U/84T/2.5mm (1Nos.) HANDLE PULLOUT 2U UNIVERSAL NATURAL (PAIR) T/B COVERS 84T/400/0.9mm SLT/ANZD (PAIR) BARS for C-Frame Support (PAIR) Length: 285 mm

Qty: 2 nos.

5. S20 5U/84T/465 mmD (extra depth)

Front Panel, Rear Panel blank, Base Plate/2mm thick Intermediate Profile (pair) PNL, S20 FRNT HNG-DW 3U/84T/2.5mm (1Nos.)PNL, S20 REAR SCR-ON 2U/84T/2.5mm (1Nos.) HANDLE PULLOUT 2U UNIVERSAL NATURAL (PAIR) T/B COVERS 84T/400/0.9mm SLT/ANZD (PAIR) BARS for C-Frame Support (PAIR) Length: 285 mm

Qty: 2 nos.

Note (1)

Maximum number of card frames will be fixed and remaining will be provided separately to be used for spare unit arrangements.

Note (2) this will be supplied with following accessories.

a)HRDWRE,FRNT PNL,SQR,PKT OF 20 – 10nos. b) EARTH CONTINUITY KIT, SPLIT – 10nos. c) EARTH CONTINUITY KIT, SPLIT – 5 nos. d) PDU 19” Octagonal Socket 6 x 5/15 Amp with 16 Amp MCB and Indicator with 3mtr Cable and 3 Pin Plug (fixed on rack)-5 nos. e) SUPRT ANGLS,HVY DTY 475mmD- 20 nos. f) AL BLANK PANEL, 19" - Al 10 SWG, 1U, 2U, 3U, 4U, 5U (3 nos. each) g) along with fixed cable trays and covers of plastic.

Note(3) :- The Scope of this item will also include the proper assembly and proper fitting of the same in the respective Table/Rack with proper fittings along with provision for safe tracking of the electrical cables with necessary earthing.

R.K. Bhatia
12/11/21
R.K.BHATIA
SO/G, AMSS/EmA&ID
BARC

Annexure A3

MAGNET MOUNTING Stainless Steel 304 made TROLLEY as per following drawings and other technical details.

Qty: 1 set

Reference drawing: MT-3090-03/04/18

Technical specifications:

Material: S.S 304 (Chemical composition and Ultrasonic Test should be conducted. Test certificate should be produced at the time of delivery)

Load testing: deflection test should be carried out for 1.5 Ton uniformly distributed load at Centre of the Trolley (Bending at centre should be within the limit as per IS standards)

Other specifications:

1. The magnet mounting top plate size of the Trolley Assembly 450 mm x 500 mm with 20 mm thick. This should be ground finish. (Flatness is 50 microns)
2. Plates for trolley (top & bottom) is 450 mm x 550 mm with 12 mm thick. (Flatness is 100 microns).
3. High quality precision heavy duty Radial Roller Strips (Diameter of rollers may be 5 or 6 mm) should be used for the movement of plates.
4. This should be firmly fixed to the plates on milled slots. (Load on the roller strips is around 1500 Kg (1.5 Ton).
5. Smooth movement is required with this load. (uniformly distributed load)
6. Total stroke required is 210 mm to 250 mm (max)
7. Properly designed heavy duty Handle should be fixed to these plates for free movement.
8. Refer to attached drawing for other details (MT-3090-03/04/18)
9. The height (Horizontal level) of the trolley should be adjustable. Height adjustment can vary from 10 mm (minimum) to 20 mm (maximum)
10. Height adjustment may be made by proper placing of the round based special silver coated S.S bolts |(Allen bolts).
11. The trolley should be able to precisely on the table top with side support plates and screws.
12. Level finish: accuracy up to 50 microns horizontal plane. (Including Flatness)

R.K.BHATIA
SO/G, AMSS/EmA&ID
BARC

THIS DESIGN AND DRAWING IS THE PROPERTY OF BHABHA ATOMIC RESEARCH CENTRE. IT MUST BE RETURNED WITH QUOTATION OR UPON DELIVERY OF MATERIAL AND EQUIPMENT AND MUST NOT BE USED EXCEPT BY PERMISSION OF THE OWNER.

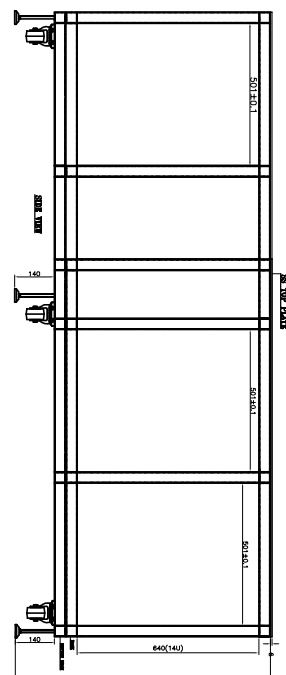
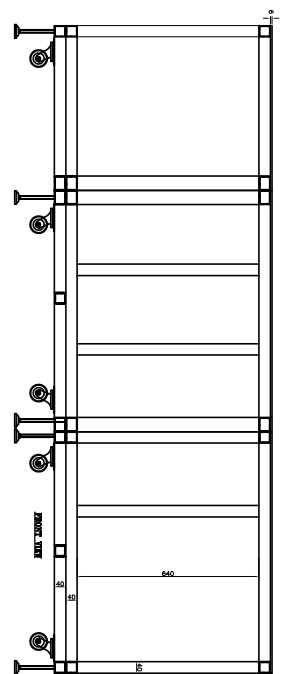
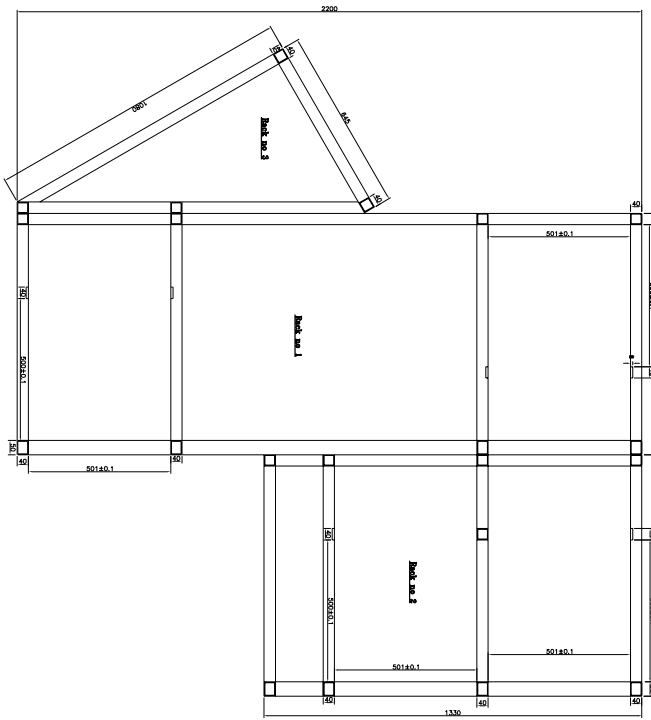

A B C D E F G H I J K L

NOTES:-
1. ALL WHEELS ARE ROTATABLE.

GENERAL TOLERANCE UNLESS OTHERWISE SPECIFIED SHOULD CONFORM TO IS 2702 (VIZ. (VERSION CLASS))		PROJECT OR SECTION	
UP TO 6	±0.1	TITLE: SIMS RACK ASSEMBLY	DATE: 12/17/2021
6 - 30	±0.2		
30 - 120	±0.3	DRG. CHG'D. 1. ERMISHANKAR	DATE: 12/17/2021
120 - 315	±0.5	DES. CHG'D. 1. ERMISHANKAR	SCALE: 1:1 & AS SHOWN
315 - 1000	±1.0	PROJECTION: 1st ANGLE	REV: 0
1000 - 2000	±1.2	1. IN DIMENSION AS SHOWN IN MILLIMETRES.	
2000 - 4000	±2.0	2. REMOVE SHARP CORNERS AND BURRS.	
4000 & ABOVE	±3.0	3. REMOVE SHARP CORNERS AND BURRS.	

DRG. No. REV. 0

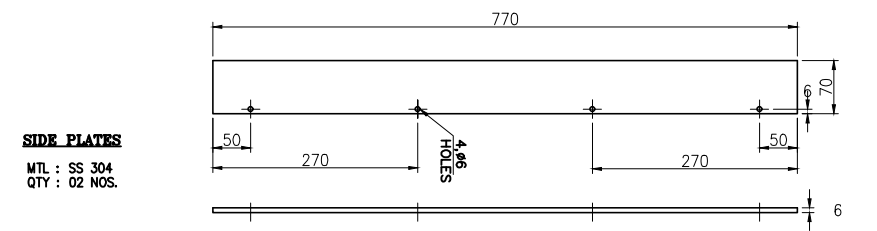
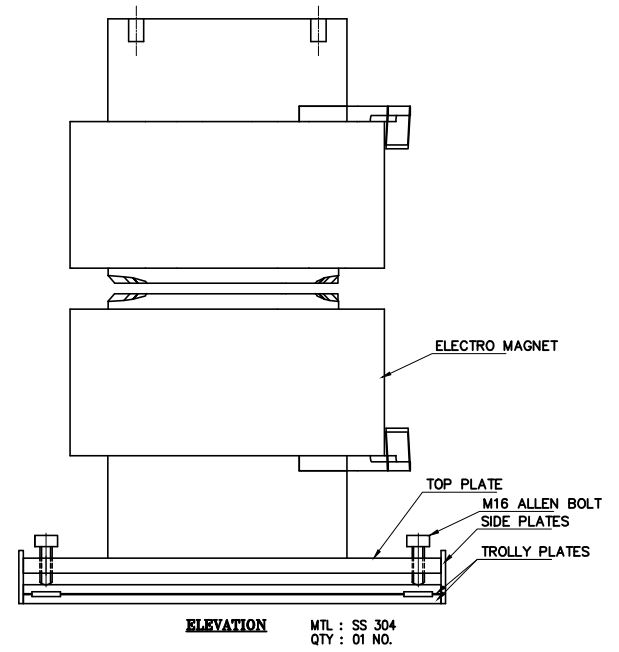
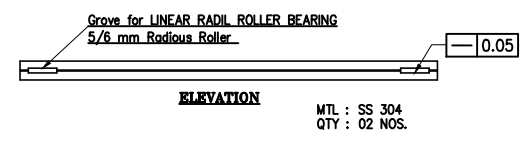
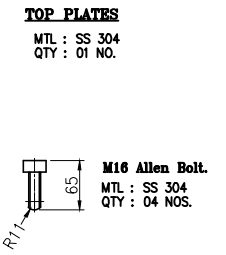
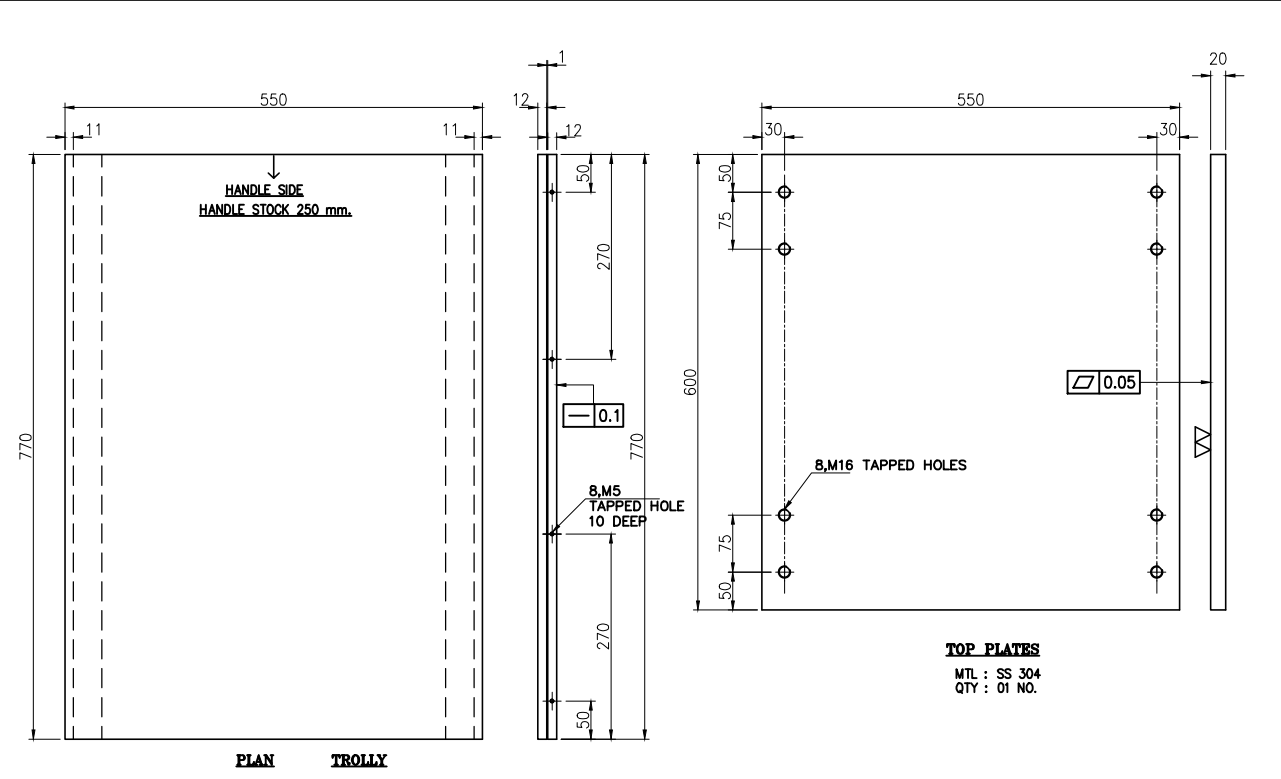
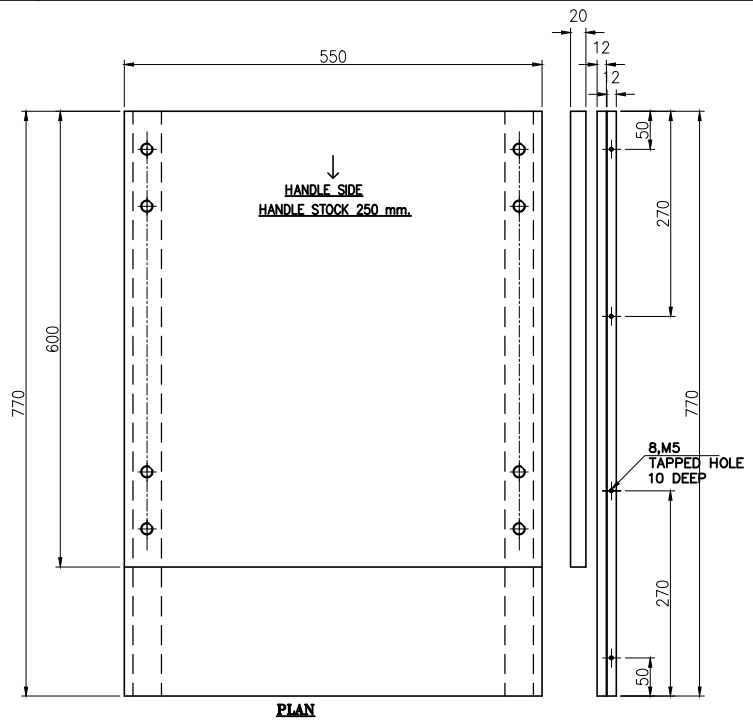

GENERAL TOLERANCE UNLESS OTHERWISE SPECIFIED SHOULD CONFORM TO IS 2102 VIZ: (MEDIUM CLASS)			PROJECT TIMS	TITLE MAGNET TROLLEY																																			
<table border="1"> <tr> <th>LINEAR DIMENSIONS</th> <th>LENGTH OF SHORTER SIDE OF ANGLE</th> <th>SURFACE FINISH IN MICRONS 3.15/CLA</th> </tr> <tr> <td>UP TO 6 ±0.1</td> <td>1 - 6 ± 1'</td> <td rowspan="2">CHAMFER 1 x 45°</td> </tr> <tr> <td>6 - 30 ±0.2</td> <td>6 - 30 ± 0°-30'</td> </tr> <tr> <td>30 - 120 ±0.3</td> <td>30 - 120 ± 0°-20'</td> <td></td> </tr> <tr> <td>120 - 315 ±0.5</td> <td>120 - 400 ± 0°-10'</td> <td></td> </tr> <tr> <td>315 - 1000 ±0.8</td> <td></td> <td></td> </tr> <tr> <td>1000 - 2000 ±1.2</td> <td></td> <td></td> </tr> <tr> <td>2000 - 4000 ±2.0</td> <td></td> <td></td> </tr> <tr> <td>4000 & ABOVE ±3.0</td> <td></td> <td></td> </tr> </table>	LINEAR DIMENSIONS	LENGTH OF SHORTER SIDE OF ANGLE	SURFACE FINISH IN MICRONS 3.15/CLA	UP TO 6 ±0.1	1 - 6 ± 1'	CHAMFER 1 x 45°	6 - 30 ±0.2	6 - 30 ± 0°-30'	30 - 120 ±0.3	30 - 120 ± 0°-20'		120 - 315 ±0.5	120 - 400 ± 0°-10'		315 - 1000 ±0.8			1000 - 2000 ±1.2			2000 - 4000 ±2.0			4000 & ABOVE ±3.0			<table border="1"> <tr> <td>DR'N:</td> <td>DATE:</td> <td>APPROVED:</td> </tr> <tr> <td>DES'N:</td> <td>DES'N:</td> <td>SHEET No.: 01 OF 01</td> </tr> <tr> <td colspan="2">GOVERNMENT OF INDIA BHABHA ATOMIC RESEARCH CENTRE</td> <td>SCALE: 1:1, 2:1 & AS SHOWN</td> </tr> <tr> <td colspan="2">PROJECT: MT-3090-03/04/18</td> <td>DRG. No. REV. 0</td> </tr> </table>	DR'N:	DATE:	APPROVED:	DES'N:	DES'N:	SHEET No.: 01 OF 01	GOVERNMENT OF INDIA BHABHA ATOMIC RESEARCH CENTRE		SCALE: 1:1, 2:1 & AS SHOWN	PROJECT: MT-3090-03/04/18		DRG. No. REV. 0
LINEAR DIMENSIONS	LENGTH OF SHORTER SIDE OF ANGLE	SURFACE FINISH IN MICRONS 3.15/CLA																																					
UP TO 6 ±0.1	1 - 6 ± 1'	CHAMFER 1 x 45°																																					
6 - 30 ±0.2	6 - 30 ± 0°-30'																																						
30 - 120 ±0.3	30 - 120 ± 0°-20'																																						
120 - 315 ±0.5	120 - 400 ± 0°-10'																																						
315 - 1000 ±0.8																																							
1000 - 2000 ±1.2																																							
2000 - 4000 ±2.0																																							
4000 & ABOVE ±3.0																																							
DR'N:	DATE:	APPROVED:																																					
DES'N:	DES'N:	SHEET No.: 01 OF 01																																					
GOVERNMENT OF INDIA BHABHA ATOMIC RESEARCH CENTRE		SCALE: 1:1, 2:1 & AS SHOWN																																					
PROJECT: MT-3090-03/04/18		DRG. No. REV. 0																																					

THIS DESIGN AND DRAWING IS THE PROPERTY OF BHABHA ATOMIC RESEARCH CENTRE. IT MUST BE RETURNED WITH QUOTATION OR UPON DELIVERY OF MATERIAL. NO REPRODUCTION OR USE IS TO BE USED EXCEPT BY PERMISSION OF THE OWNER.

A B C D E F G H I J K L