



GOVERNMENT OF INDIA
DEPARTMENT OF ATOMIC ENERGY
BHABHA ATOMIC RESEARCH CENTRE
VISAKHAPATNAM



Computational Analysis Division

Ref: CAD/HEDM/WO/IND/22-23/29

Date: 15/02/2023

Sub: Notice inviting tender for “CNC Fabrication and Assembly of SS304, Al-7075 and Acrylic components for high precision measurements, and supply of required accessories.”

**1. Scope : CNC Fabrication of components as given in drawings attached and Supply of Accessories.
(Details: Annexure I, II, III)**

Note: The items are for delivery and testing at BARC Facilities, Atchutapuram, Visakhapatnam-531011.

2. General guidelines for submitting tender

- You shall send your offer in a **sealed envelope** indicating delivery period, price inclusive of taxes and other relevant information by speed post/Courier to:

Head,
Computational Analysis Division
PEB-04, North Gate Main Campus
Bhabha Atomic Research Centre
Maduturu, Near Nagaravaram-Atchutapuram Highway
Visakhapatnam 531011
(Kind Attention : Shri. Subhrajit Guin, SO/D, Mob: 9007295617)

- Quotation shall reach us on or before **22/02/2023** by **Speed Post/Courier Only**
- On top left corner of the envelope please indicate
Quotation For – CNC Fabrication and Assembly of SS304, Al-7075 and Acrylic components for high precision measurements, and supply of required accessories:
Due Date 22/02/2023
- Price to be specified **strictly as per template** provided in Annexure-II.
- Overwriting, scratching etc. must be avoided in the quotation. Rewriting the whole figure shall carry out any alteration in the figure. The authorised person from the firm shall countersign such figure.
- The delivery period mentioned in the quotation shall be strictly adhered to. If the contractor fails to supply and secure extension of delivery date before effecting delivery of the supply against the contract, acceptance of such item by the purchaser will in no way prejudice the right of the purchaser to levy liquidated damage nor will it be entitled to the contractor for payment of statutory levies that comes into force after the expiry of the delivery date.
- Minimum Guarantee / Warranty period** of the materials shall be **one year**.
- Supplier shall mention clearly the PAN /TAN no. on quotation.**
- GST number shall be clearly mentioned on Quotation**
- All the charges and taxes shall be mentioned clearly.

Subhrajit Guin

3. PLACE OF DELIVERY AND TESTING: BARC Facilities, Atchutapuram, Visakhapatnam-531011

The inspected and accepted components shall be delivered to:

**The Stores Officer.
Bhabha Atomic Research Centre
Main Campus (North Gate), PEB-4, Village: Maduturu,
Near Nagaravaram-Atchutapuram Highway
Visakhapatnam 531011**

4. PAYMENT TERMS:

- (1) Part payment/Advance or against delivery cannot be made.
- (2) Payment will be made only after satisfactory completion of work and on production of (along with Delivery Challan):
 - i. Bill/Invoice containing Location of supply, separate tax components along with PAN and GSTN numbers
 - ii. Advance Stamped Receipt
 - iii. Bank Account No, Bank and Branch name with IFSC code.
 - iv. Undertaking stating that GST has been promptly deposited with the authorities
- (3) It may be noted that:
 - i. Income tax @2% will be deducted from your bill.
 - ii. TDS(under GST) will be deducted as applicable from your bill of taxable goods and/or services, where the total value of such supply exceeds 2.50lakh.

5. CONFIDENTIALITY CLAUSE :

No party shall disclose any information to any third party, concerning the matters under this contract generally. In particular, any information identified as "Proprietary" in nature by the disclosing party shall be kept strictly confidential by the receiving party and shall not be disclosed to any third party without the prior written consent of the original disclosing party.

This clause shall apply to the sub-contractors, consultants, advisers or the employees engaged by a party with equal force. "Restricted information" categories under section 18 of the Atomic Energy Act,1962 and "Official Secrets" under section 5 of the official secrets act, 1923;-

Any contravention of the above-mentioned provisions by any contractor, sub-contractor, consultant, adviser or the employees of a contractor will invite penal consequences under the aforesaid legislation.

Prohibition against use of BARC's name without permission for publicity purposes:-The contractor or sub-contractor, consultant, adviser or the employees engaged by the contractor shall not use BARC's name for any publicity purpose through any public medial like press, radio, T.V. or Internet without the prior written approval of BARC.

6. You may contact us for any clarification before 22/02/2023 (Contact Person: Shri. Rahulnath PP, 0891-2832142, rahulnathpp@barc.gov.in or Shri. Subhrajit Guin, 0891-2832144, sguin@barc.gov.in)

Subhrajit Guin
SO/D, CAD.

Scope of Work

CNC Fabrication and Assembly of SS304, Al-7075 and Acrylic components for high precision measurements, and supply of required accessories.

Note:

- (1) *All the parts must be fabricated from single piece only (without involving any welded parts) and must be done in CNC only. For any doubt, kindly contact:* (Contact Person: Shri. Rahulnath PP, 0891-2832142, rahulnathpp@barc.gov.in or Shri. Subhrajit Guin, 0891-2832144, sguin@barc.gov.in).
- (2) *To periodically check the progress of work, inspection may be carried out by our team, at the vendor's manufacturing site. This will be preceded by a 2-days prior notice, from our end to the vendor.*
- (3) *Pre-Dispatch Inspection shall be carried out once the fabrication is completed and all the materials are ready.*
- (4) *The Vendor should not dispatch the materials before the Pre-Dispatch Inspection is completed.*

Brief Description of Work:

The above work consists of the following

- (1) Fabrication of each component from single piece only, with CNC only.
- (2) Assembly of the components to form fully-functional assemblies.
- (3) Supply of the above assembly along with Accessories Required.

Following Fabrications are to be carried out: (Refer Assembly Drawings in Annexure III)

Drawing No	Title	Quantity	Remarks
0	Assembly Drawing		Bill of Materials demonstrates the parts required to form an assembly. However, if multiple quantities of a component are to be fabricated, then each should fit in the assembly as per the drawing.
1	Spindle	01 Nos	ID Taper is very critical.
2	Spacer	06 Nos	OD should match the ID of DRG No. 1.6
3	Target Holder	01 Nos	<ul style="list-style-type: none"> • Through ID 25mm should match the OD of DRG No. 3 • Slot Threading should match the OD threading of DRG No. 5. • Slot ID should match the OD of DRG No. 4
4	Target Plate	10 Nos	OD should match the Slot ID of DRG No. 3
5	Plate Arrestor	03 Nos	OD Threading should match the threading on ID of DRG No. 3
6	Acrylic Backing	10 Nos	OD 25mm should match the ID 25mm of DRG No. 3
7	Acrylic Arrestor	02 Nos	
8	Square Backing Plate	01 Nos	

I. List of Required Accessories:

Accessories to be supplied	(1) M8 CSK Bolts & Nuts - (18 Sets) (2) M3 Bolts & Nuts - (18 Sets) (3) M6 Bolts & Nuts - (18 Sets)
-----------------------------------	---

I. General Requirements:

1. One year (or more) standard warranty has to be provided on the fabricated items.
2. Work should be carried out by trained personnel only.

Subhrajit Guin

3. Staying inside the office premises after the working hours is not permitted. All the materials, profiles, sections has to be fabricated and assembled outside the campus as per the requirements only and the same is not permitted inside the labs.
4. Working days include Monday-Friday 10:00am to 5:00pm (Saturday & Sunday are holidays), work completion period has to be planned accordingly.
5. Single order will be placed for the entire work and no partial work is permitted.
6. Delivery should be completed within 30 working days from the commencement of the work order.
7. Any delay which is attributable to the contractor is liable for penalty @ ½% per week (max 5%) to be imposed on the contractor.
8. The vendor should accept & provide the material as per the description & specifications mentioned. Those who fail to provide the acceptance for the material their quotation technically will not be accepted

Subhrajit Guin

Subhrajit Guin
SO/D, CAD.

Contact Persons :

<p>1. Shri Subhrajit Guin (Indenting Officer) SO/D, Computational Analysis Division BARC Visakhapatnam Ph: 0891-283-2144 Email: sguin@barc.gov.in</p>	<p>2. Dr Sambaran Pahari SO/G, Computational Analysis Division BARC Visakhapatnam Ph: 0891-283-2140 Email: sambaran@barc.gov.in</p>
--	--

COMMERCIAL QUOTE : TEMPLATE OF PRICE BREAKUP

Annexure II

Prices should be stated strictly as per below template.

<i>Please Tick below to indicate whether the critical requirements have been understood</i>			
Each component from single-piece only: Yes / No	CNC machining only: Yes / No	All Tolerances in the drawings have been understood: Yes / No	
S No.	Title	Quantity	Price
1.	Spindle	01 Nos	-
2.	Spacer	06 Nos	
3.	Target Holder	01 Nos	
4.	Target Plate	10 Nos	
5.	Plate Arrestor	03 Nos	
6.	Acrylic Backing	10 Nos	
7.	Acrylic Arrestor	02 Nos	
8.	Square Backing Plate	01 Nos	
9.	Accessories: (1) M8 CSK Bolts & Nuts - (18 Sets) (2) M3 Bolts & Nuts- (18 Sets) (3) M6 Bolts & Nuts - (18 Sets)	01 Set	
		Total	-
		Misc Charges (Freight etc)—if any	-
		Tax	-
		Total (with Tax)	-

Subhrajit Guin

Annexure - III (Drawings)

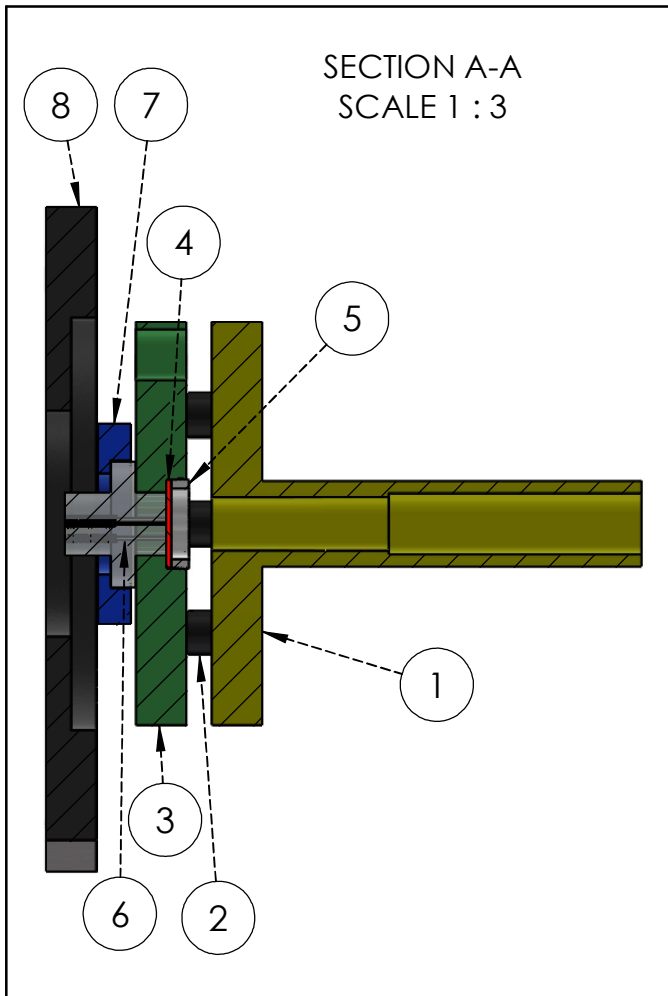
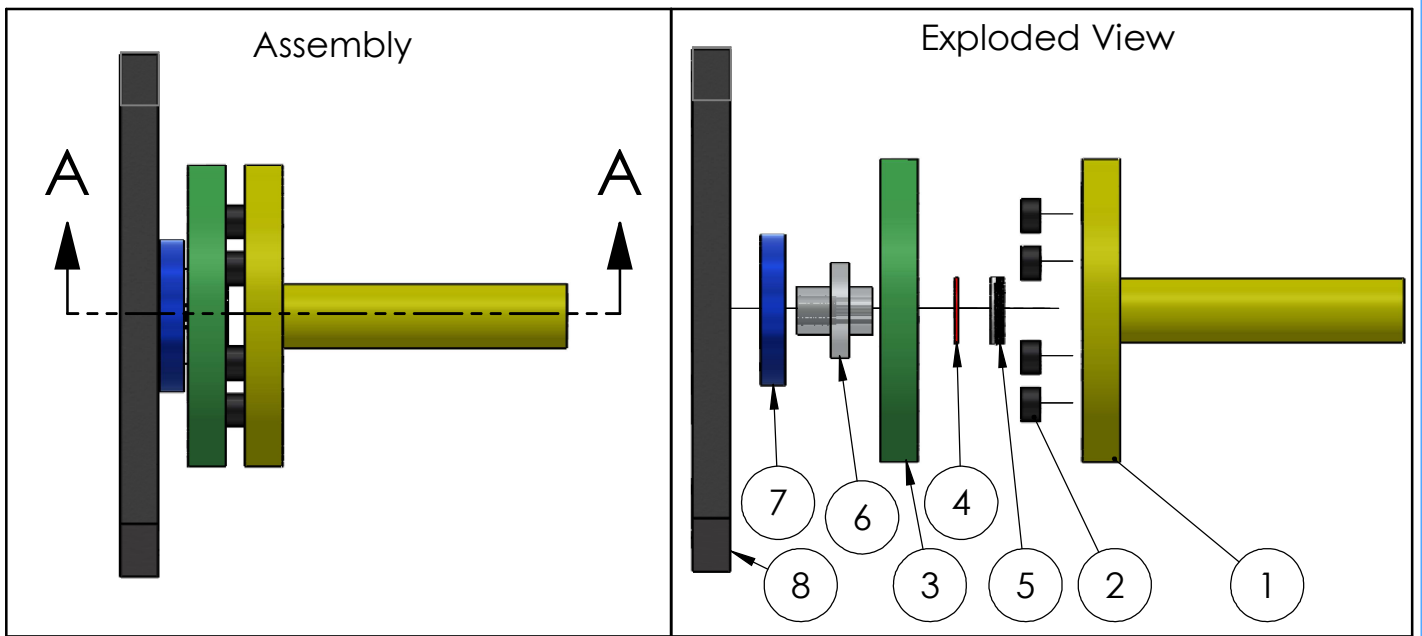

DRG NO.	DESCRIPTION	QTY.
1	Spindle	1
2	Spacer	6
3	Target Holder	1
4	Target Plate	1
5	Plate Arrestor	1
6	Acrylic Backing	1
7	Acrylic Arrestor	1
8	Square Backing Plate	1

	Project: Precision Experiments	Title: Assembly Drawing for Precision Expts Setup Dated 03.02.2023	
DRG. No.: 0	All dimensions are in mm	Tolerance:	
Quantity: 1 Set		Scale: 1:1	
DATE: 03.02.2023	Drawn: Subhrajit	Approved: Rahulnath	

Subhrajit Guin

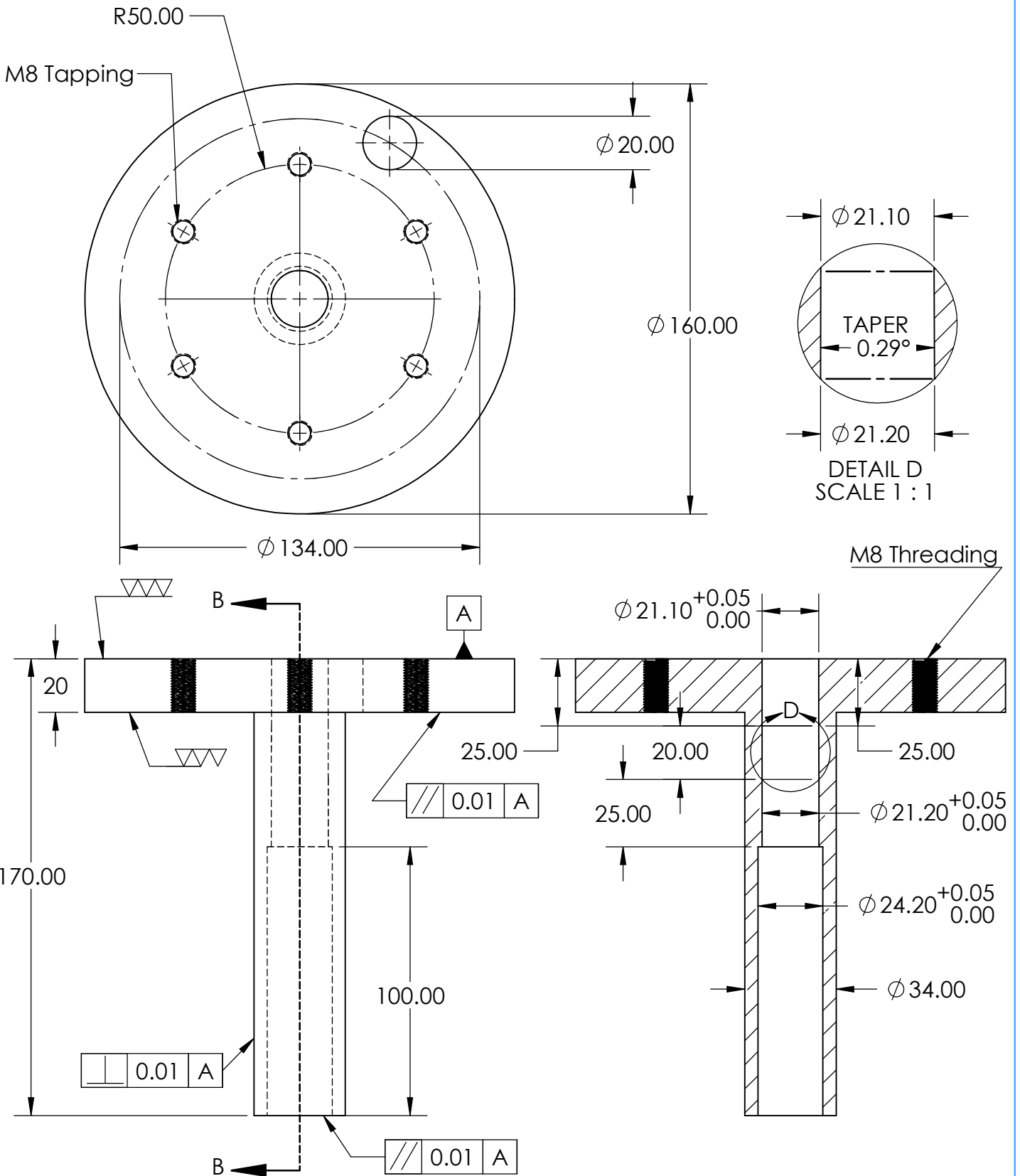

Spindle for Precision Expts

DRG.NO : 01	All Dimensions are in mm		
Quantity : 01Nos	Scale :	Material: SS	
Date : 03/02/2023	Tolerance: +/- 0.1	Name&Sign : Rahulnath	

Subhrajit Guin

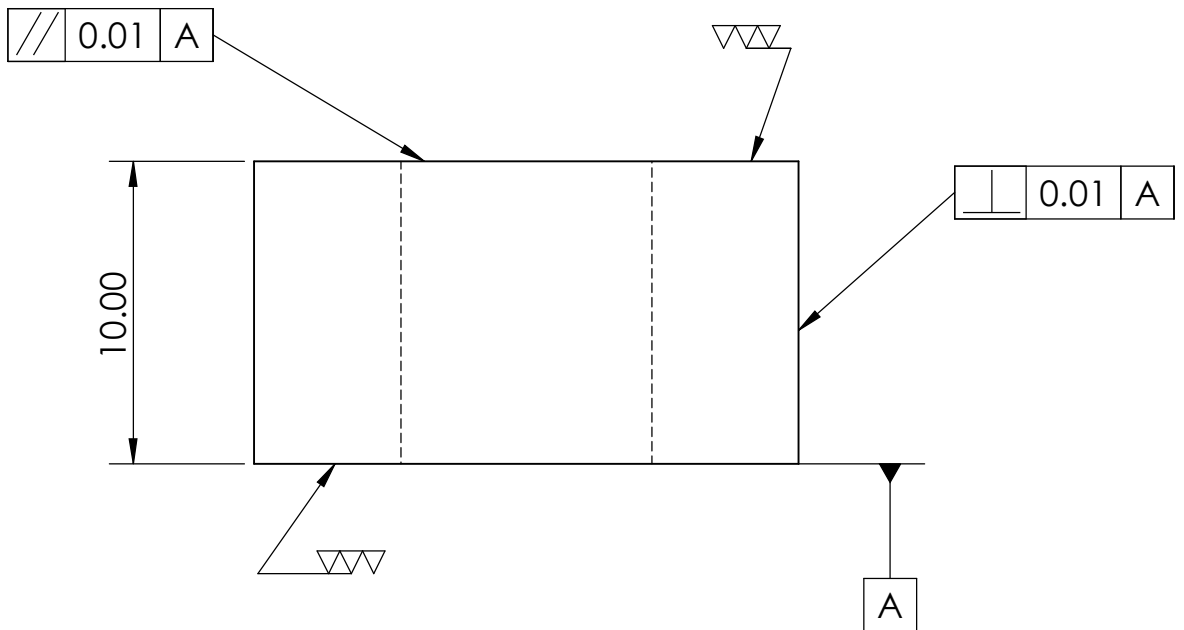
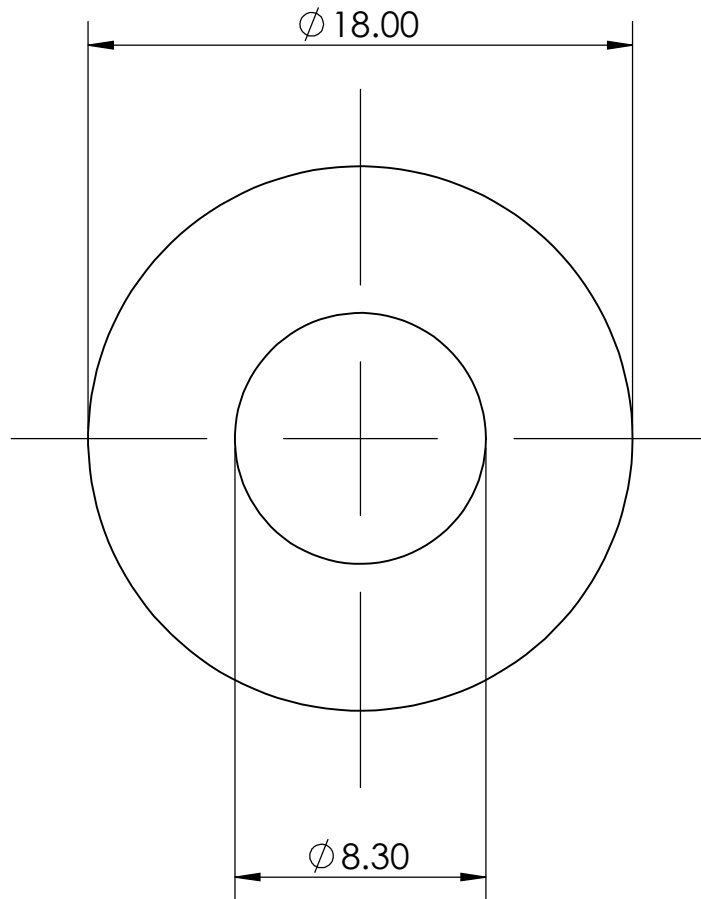

Spacer for Precision Expts

DRG.NO : 02	All Dimensions are in mm		
Quantity : 06Nos.	Scale :	Material: SS	
Date : 03/02/2023	Tolerance: +/- 0.1	Name&Sign : Rahulnath	

Subrajit Guin

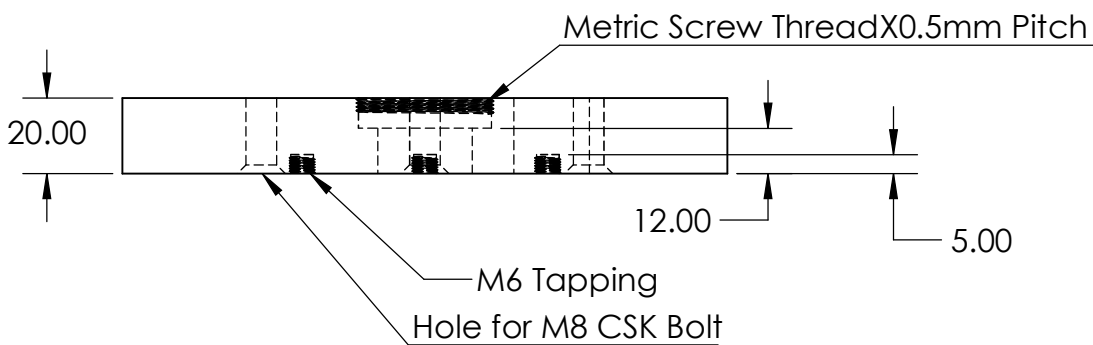
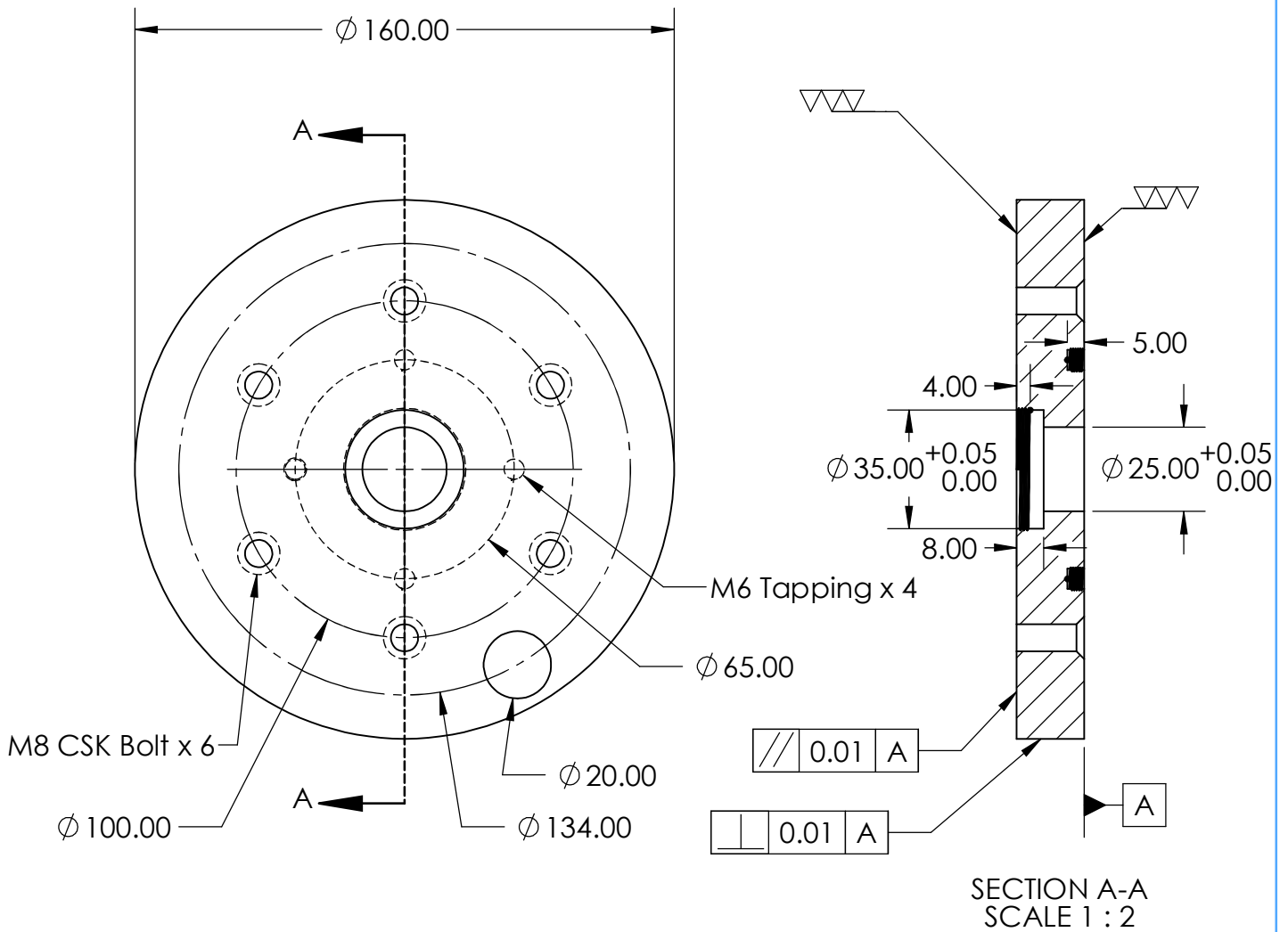

Target Holder for Precision Expts

DRG.NO : 03	All Dimensions are in mm		
Quantity : 01No.	Scale :	Material: SS	
Date : 03/02/2023	Tolerance: +/- 0.1	Name&Sign : Rahulnath	

Subrajit Guin

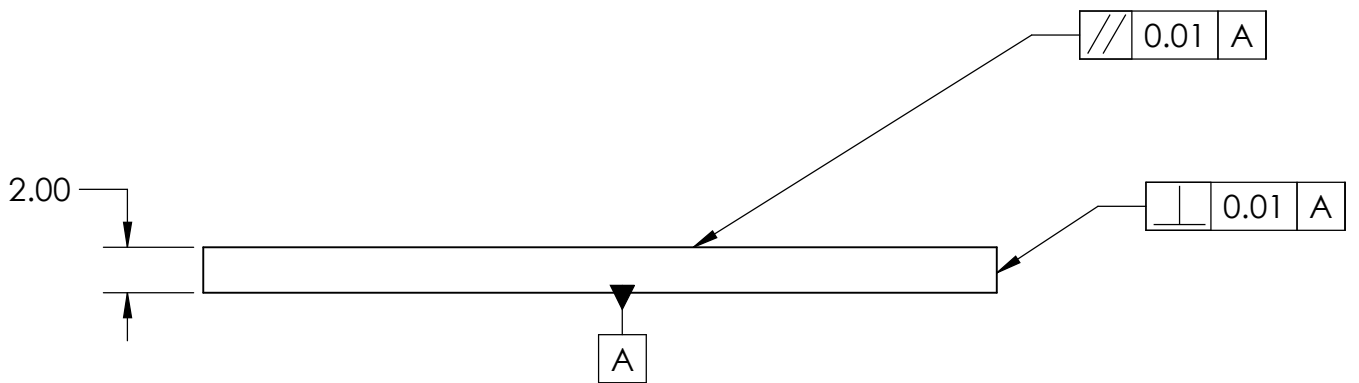
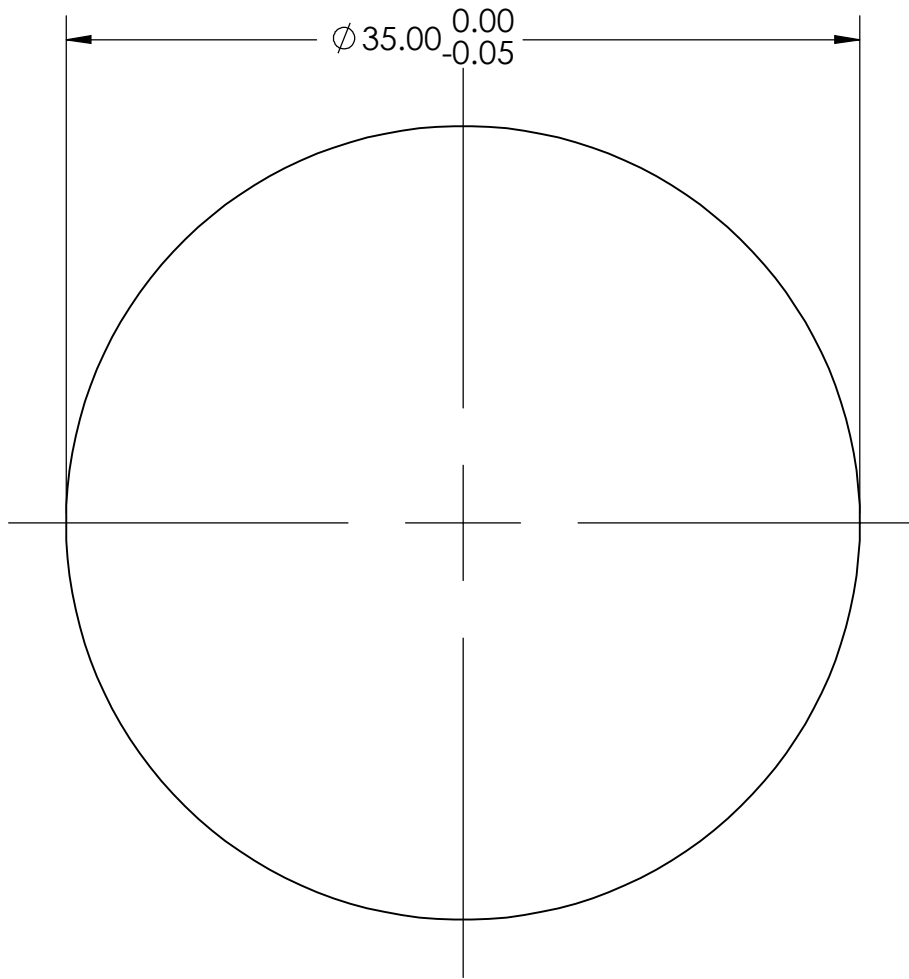

Target Plate for Precision Expts

DRG.NO : 04	All Dimensions are in mm		
Quantity :10Nos.	Scale :	Material: Al-7075	
Date : 03/02/2023	Tolerance: +/- 0.1	Name&Sign : Rahulnath	

Rahulnath

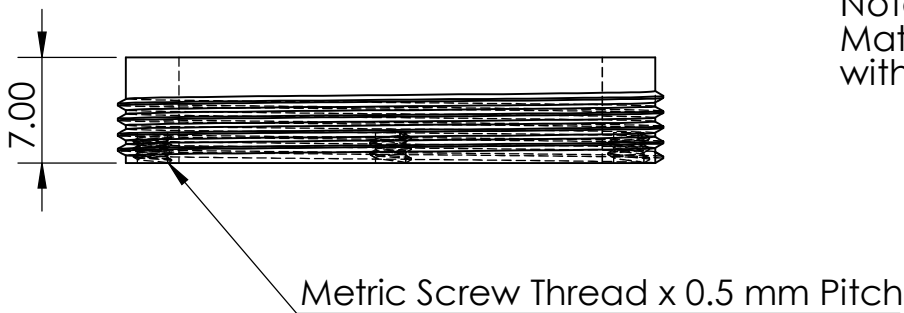
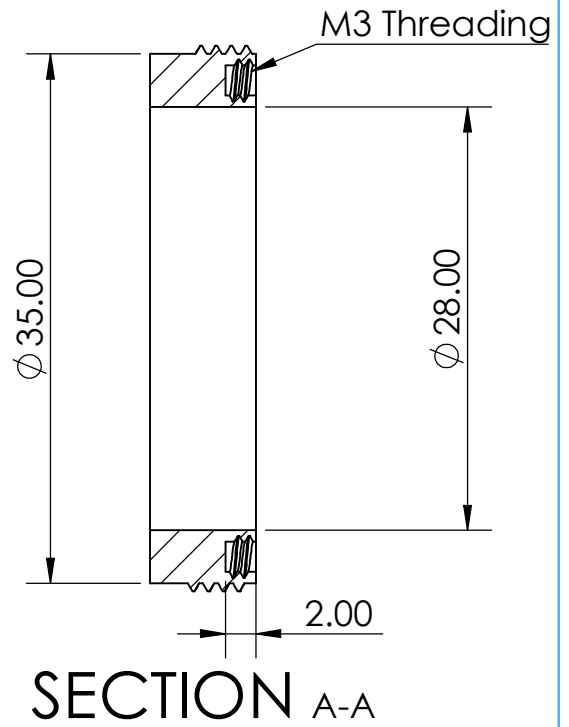
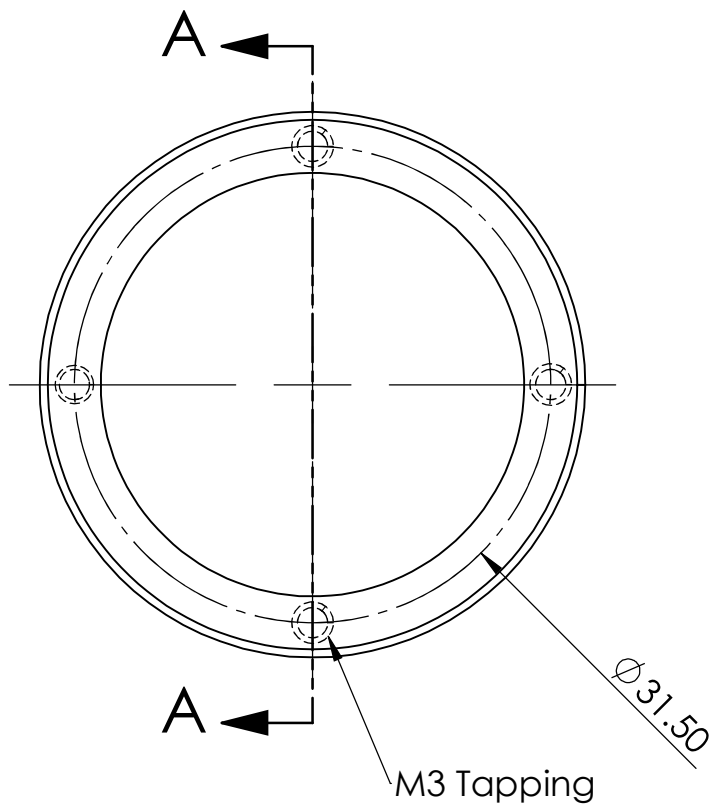

Note:
Mating Component
with Target Holder (DRG No 3)

Plate Arrestor for Precision Expts

DRG.NO : 05	All Dimensions are in mm		
Quantity : 03Nos.	Scale :	Material: SS	
Date : 03/02/2023	Tolerance: +/- 0.1	Name&Sign : Rahulnath	

Subhrajit Guin

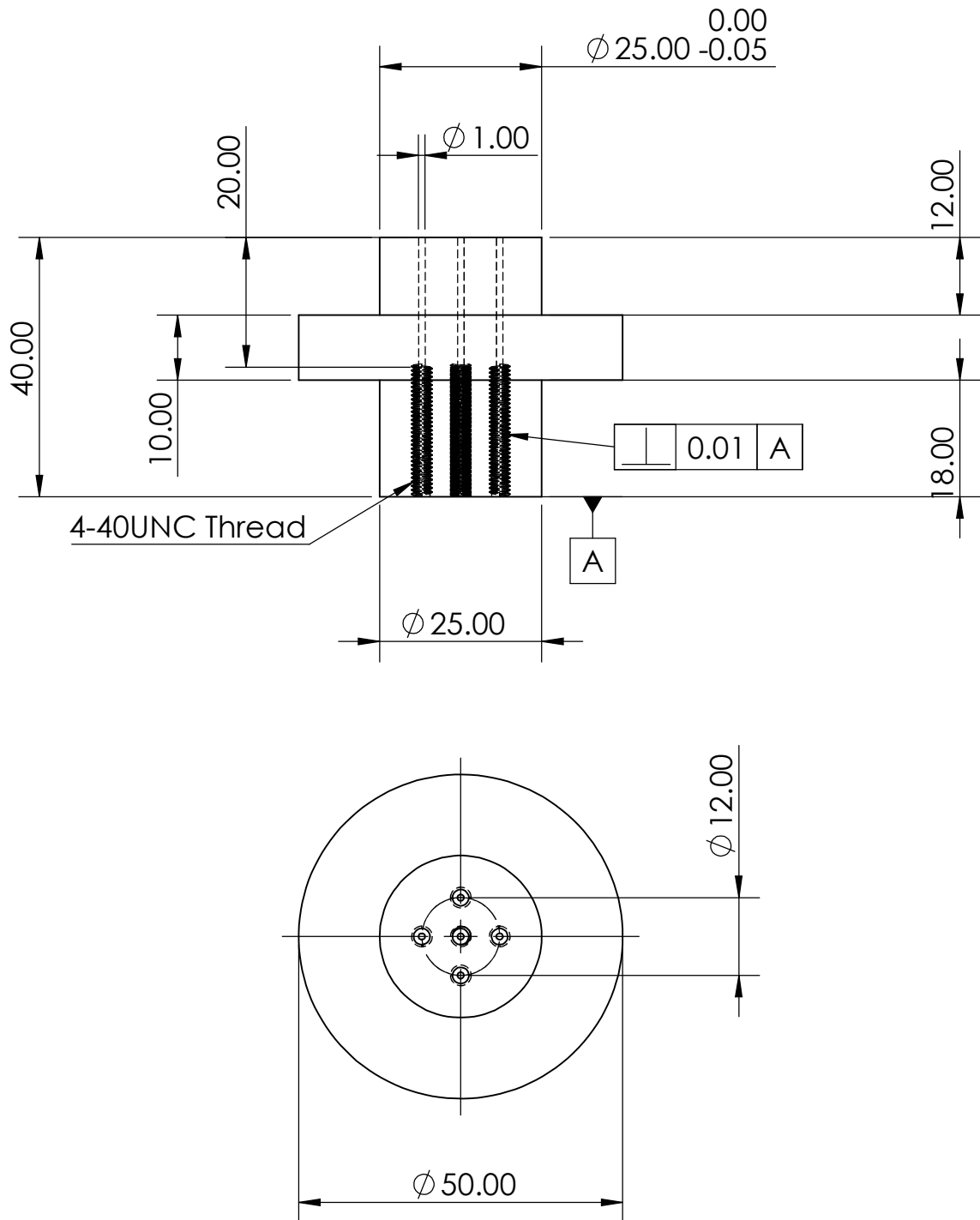

Note: After Fabrication of 1 Piece
it is to be Checked & Qualified
before proceeding further

Acrylic Backing for Precision Expts

DRG.NO : 06	All Dimensions are in mm		
Quantity :10Nos.	Scale :	Material: Acrylic	
Date : 03/02/2023	Tolerance: +/- 0.1	Name&Sign : Rahulnath	

Subhrajit Guin

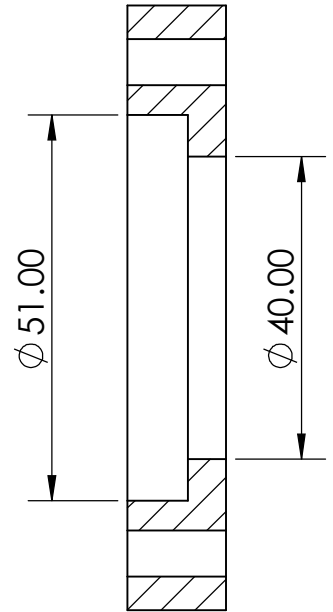
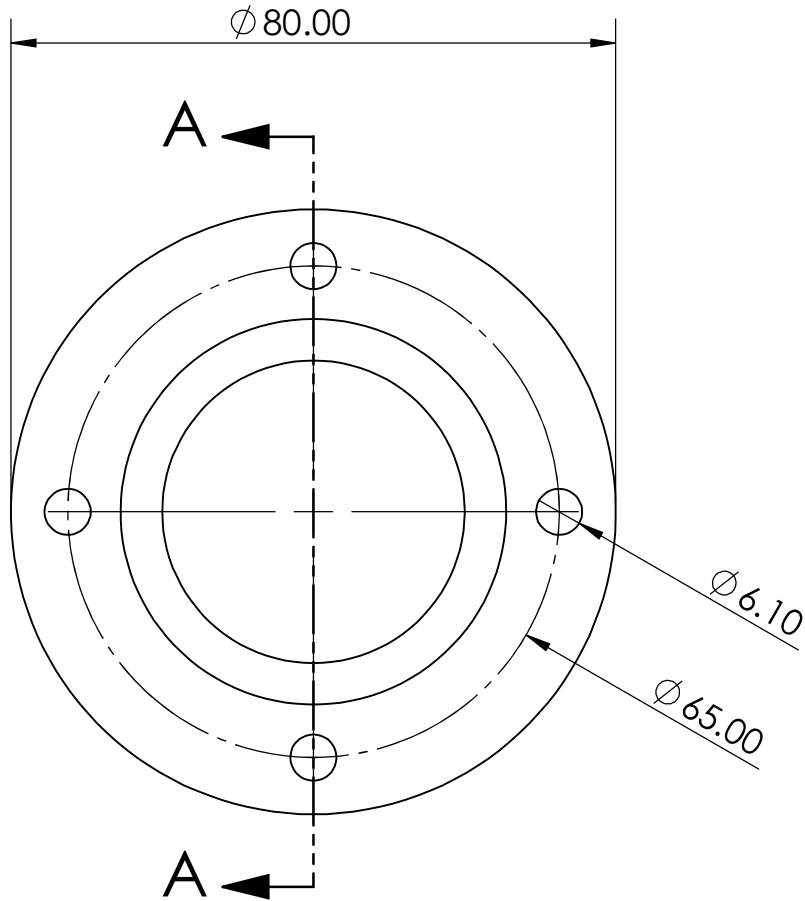

SECTION A-A

SCALE 1 : 1

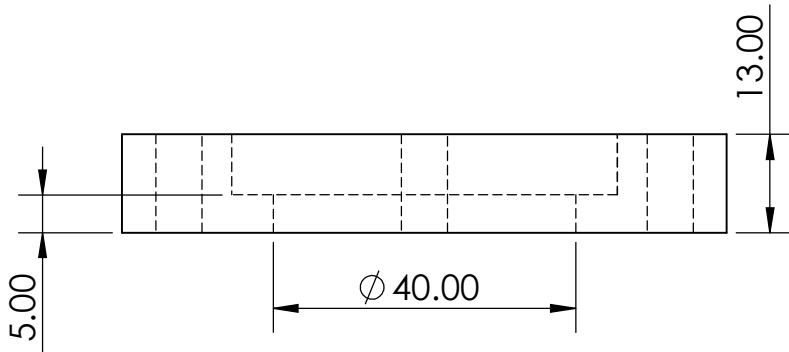

Acrylic Arrestor for Precision Expts

DRG.NO : 07

All Dimensions are in mm

Quantity : 02Nos.

Scale :

Material: SS

Date : 03/02/2023

Tolerance: +/- 0.1

Name&Sign : Rahulnath

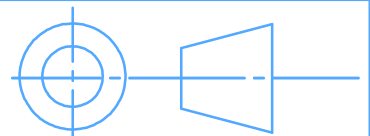

Subrajit Guin

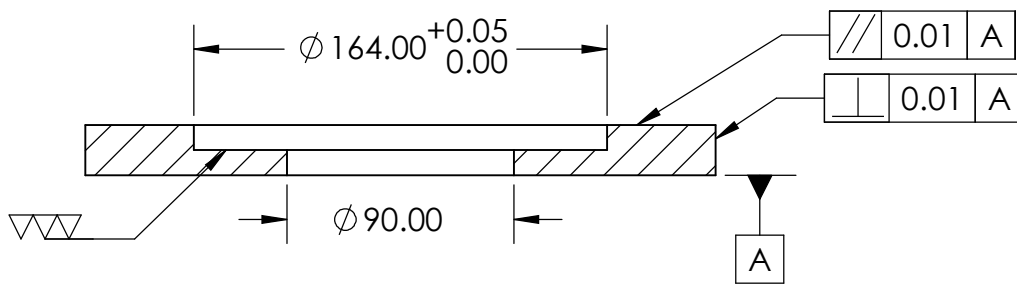
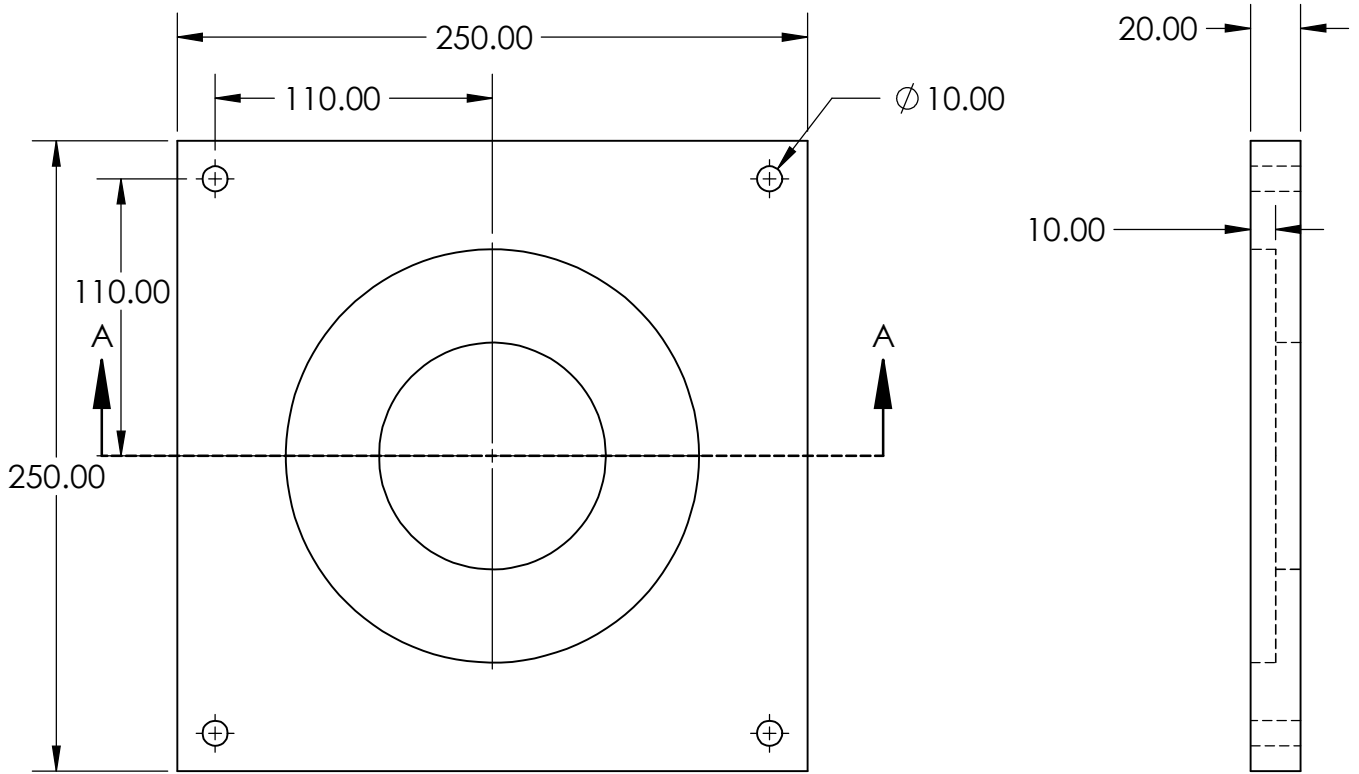

SECTION A-A
SCALE 1 : 3

Square Backing Plate for Precision Expts

DRG.NO : 08	All Dimensions are in mm		
Quantity : 01Nos.	Scale :	Material: SS	
Date : 03/02/2023	Tolerance: +/- 0.1	Name&Sign : Rahulnath	

Subhrajit Guin