

TELEPHONE : 022 25593853

FAX : 91-22-2550 5151  
: 91-22-2550 5363



TROMBAY,  
MUMBAI - 400 085

GOVERNMENT OF INDIA  
BHABHA ATOMIC RESEARCH CENTRE  
DIVISION OF REMOTE HANDLING & ROBOTICS (DRHR)

---

Ref: DRHR /APD/MF/ENQ/295

Date: 8/06/22

Sub: Minor Fabrication -**Invitation of quotation for Fabrication of Eye Plaque Dosimeter and surface profiling system.**

**Dear Sir/Madam,**

1. Quotations are invited for the minor fabrication job: Fabrication of Eye Plaque Dosimeter and surface profiling system as per enclosed specifications, Annexure - I.
2. The job involves the fabrication, assembly , demonstration and testing of the working system at supplier's site and delivery of the system at DRHR, BARC, Trombay, Mumbai.
3. Supplier shall fabricate the items with material. **(No Free issue material will be supplied by BARC.)**
4. Taxes and other charges, if any, shall be quoted separately.
5. The quotation must reach Head, DRHR, BARC by **24<sup>th</sup> June 2022** and must be sent in a sealed envelope superscribed with the **reference number & the due date given above.**
6. The quotation shall be in **two parts, a commercial offer, and a technical offer.** Each sealed separately in individual envelopes and each **super-scribed "Commercial" or "Technical"** as the case may be.
7. The quotation should be sent by **speed post/ registered** post through Indian Postal Services only. The envelope shall be addressed to:

**Head, DRHR,  
BARC, Trombay, Mumbai - 400 085.  
(Attn.: Amaren P Das, DRHR)**

8. The fabrication and assembly work shall be subjected to inspection by our engineer. The finished unit shall not be dispatched prior to approval by our engineer at bidder's premises. The unit shall be delivered by the bidder at **DRHR, BARC, Trombay, Mumbai.- 400085.**

9. Head, DRHR, BARC reserves the right to accept / reject any or all quotations without assigning any reason.
10. Incomplete offer / offer received after the due date/ offer not sent in two parts shall not be considered.
11. The bidder shall provide break-up cost for material, fabrication, other charges and taxes in the quotation.
12. Quotations should be preferably neatly typed and **corrections are not acceptable**.
13. Quotation must indicate the **delivery period** and the **validity of offer**.
14. Quotation received in computer-generated form shall not be acceptable. Quotation must be submitted in printed letterhead, mentioning clearly GST registration no., PAN No. & Service Tax Registration Number. Submission of challan and Invoice shall also comply the same, in case, work order is placed.
15. Drawings must be returned along with the offer.

Encl.: Annexure – I

## Annexure – I

### Scope of work:

Fabrication, assembly, demonstration and supply of the **Eye Plaque Dosimeter and surface profiling system** as per detailed drawing and reference document attached.

Material required for manufacturing and procedure qualification shall be arranged by supplier.

Minor fabrication. Job description	Quantity	Reference document
Fabrication and assembly of mechanical system.	As per Drawings	As per Table 1
Fabrication of Encoder mounting base.	2Nos.	Depending on model of encoder purchased by the fabricator.
Fabrication and wiring of control unit. Including customised microcontroller board and counter unit.	As per ref Doc	Drawing no DRHR-172-EPA-E 01 and 02
Basic Testing of System.	--	Smooth running of all 3 axes.

### Delivery and Guarantee

1. **Consignee:** DRHR, BARC, Trombay, Mumbai. .
2. **Guarantee:** The items under the work order shall be guaranteed for a satisfactory performance against manufacturing defects and faulty workmanship, for a period of 12 months from the date of final acceptance
3. All work shall be done with good workmanship. Our supervisor will supervise the quality of work.

### Deliverables:

1. As built drawing
2. The complete unit as specified above.
3. Allen key and spanner set as required for assembly and disassembly of the system.
4. Data sheet and supplier's address of Motor, sensors and other bought out items.

### Others Terms and Condition

- Vendor should have sufficient experience & expertise in machining and fabrication of mechanical parts.
- Vendor should have in house facility for machining, welding and assembly.
- Supplier must have resources for fabrication of control unit, microcontroller board and electronic board testing facility.
- If required one site visit would be conducted before evaluation of offer.
- No free issue material will be supplied by BARC.

*Table 1 : List of Drawings*

Sl No.	Drawing No
1	DSEA/DRHR/2021-22/300 - 19
2	DSEA/DRHR/2021-22/350 - 56
3	DSEA/DRHR/2021-22/100

*Table 2: List of Std. Components*

Sl.No.	Name of Item	Make	Model	Qty
1	Stepper Motor : Step angle 1.8° , holding torque: 0.36Nm Torque @100rpm: 400mNm Flange size 42mm Sq,	Bholanath	BH 42 SH 38-1684	2
2	Linear Actuator. (stepper motor based)	Portescap	20DAM40D1B-k	1
3	Driver : for above motor Input voltage 24VDC Current /phase:2amp Provision for micro stepping Pulse direction mode control		To match Part in serial no 1 &2	3 (2+1)
4	<b>Digital Linear Measurement Transducer probe:</b> Range: 5mm, Acc:0.5%/0.1micron, Repeatability: 0.15micron, tip force spring push:0.7N, body dia 8mm, tip ball dia 3.5mm	Solartron	Orbit-DP/5/S	1
5	Computer interface USB based for part at serial no 4.	Solartron	USBIM Mk2 Pack	1
6	Power supply: 230 VAC to 24 VDC 5 A	Meanwell/ Shavision Or any reputed make		1
	Power Converter 24VDC to 5VDC	Meanwell/ Shavision Or any reputed make		2
7	Miccontroller Board	Custom built or Std.		1



8	Encoder optical : Incremental, 5vdc, 2500PPR (ABZ), body dia max 40mm			2 (Hollow ) 1 (shaft)
9	Encoder counter board with SPI	(LS7166 based or similar )		3
10	Limit switch and Knobs			As required
11	Control box/housing for electronic boards			As required

### **General Specifications**

#### **1. Quality surveillance, inspection**

- 1.1. All work covered shall be subject to quality surveillance / inspection by the purchaser or his authorized representative.
- 1.2. No Insurance policy is required for the material as the job is to be done by supplier's material.

#### **2. Delivery**

- 2.1. The bidder shall finish the work after approval by our engineer within **3 months** from the date of firm Work order issued to the bidder.
- 2.2. Any delay which is attributable to the supplier is liable for penalty @ 0.5% per week (max.10%) to be imposed on supplier.
- 2.3. In case any extension in delivery is to be granted to the supplier. The supplier should request for the extension before expiry of the work order. The same may be justified by the Division, whether extension granted is with or without levy of liquidated damages.

#### **3. Sub-Contract**

- 3.1. The fabricator shall not sub-contract any or all the work without written consent from the purchaser. The fabricator shall be responsible to the purchaser for all work carried out the sub-contractor, of the fabricator, if allowed by the purchaser.

#### **4. Payment**

- 4.1. Payment will be made only after satisfactory completion of work and against submission of original GSTN Invoice/Bill in triplicate, warranty /guarantee certificate, Undertaking as per Annexure-II, cancelled cheque, option form for payment through ECS/RTGS and pre-stamped receipt.
- 4.2. Advance /Part Payment or against delivery cannot be made.
- 4.3. GSTN Invoice must have GSTN, PAN, Location of Supply and Tax component separately indicated.

#### **5. Tax**

- 5.1. Income Tax of **1.5%** & **GST TDS 2%** on the bill amount shall be deducted in payment.

#### **6. Confidentiality**

- 6.1. No party shall disclose any information to any third party concerning the matters under this contract generally. In particular, any information identified as "**Proprietary**" in nature by disclosing party shall be kept strictly confidential by the receiving party and shall not be disclosed to any third party without the prior written consent of the original disclosing party.
- 6.2. This clause shall apply to sub-contractors, consultants, advisors or the employees engaged by a party with equal force.

7. **"Restricted information" categories under section 18 of the Atomic Energy Act,1962 and "Official Secrets" under section 5 of the Official Secrets Act, 1923:-**
  - 7.1. Any contravention of the above mentioned provisions by any contractor, sub-contractor, consultant, advisor or the employees of the contractor will invite penal consequences under the aforesaid legislation.
8. **Publication against use of BARC's name without permission for publicity purpose:-**
  - 8.1. The contractor or sub-contractor, consultant, advisor or the employees engaged by the contractor shall not use BARC's name for any publicity purpose through any public media like Press, Radio, T.V. or Internet without the prior written approval of BARC.

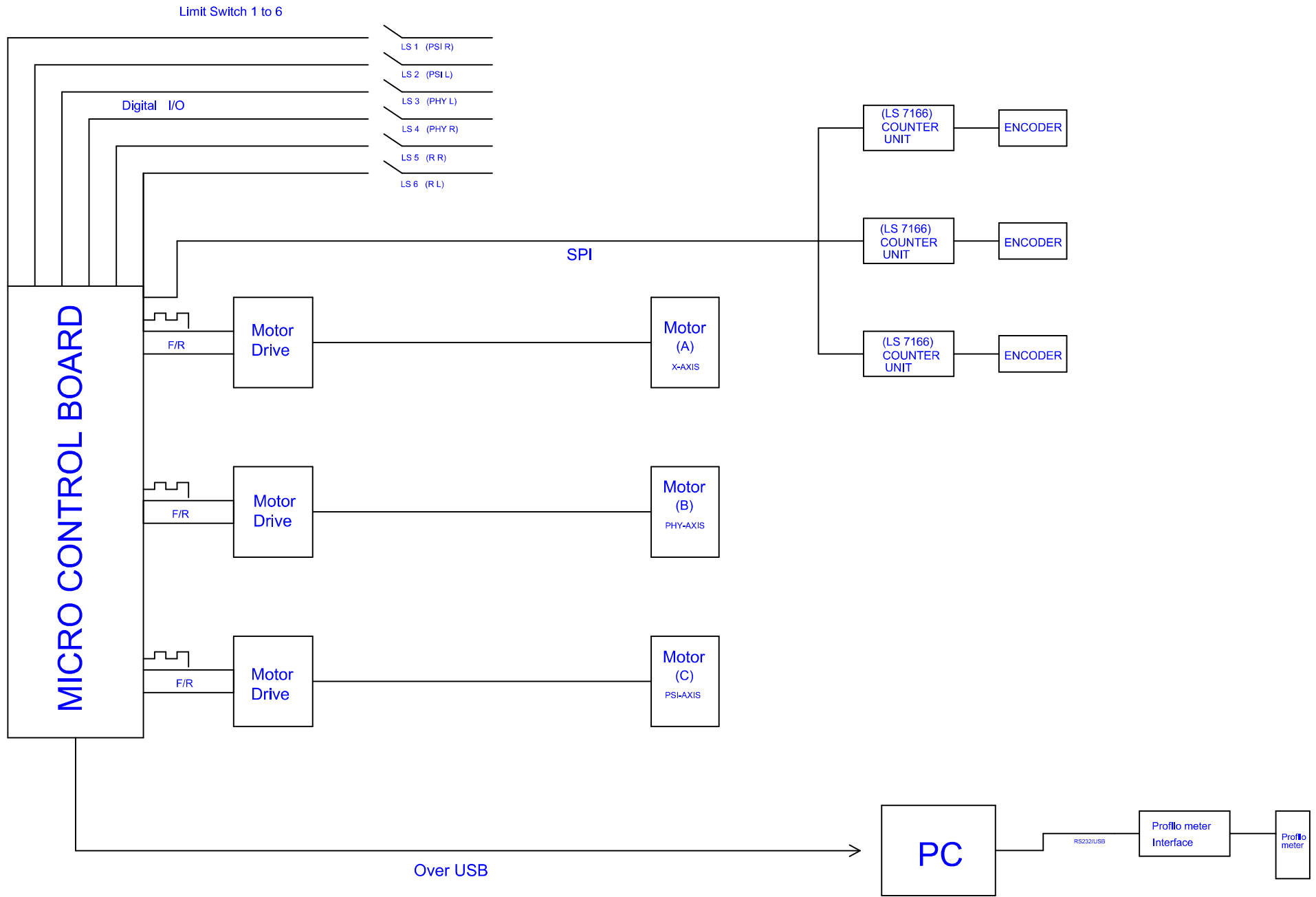

DRAWING NO.  
A4-DRHR-172-EPA-E01

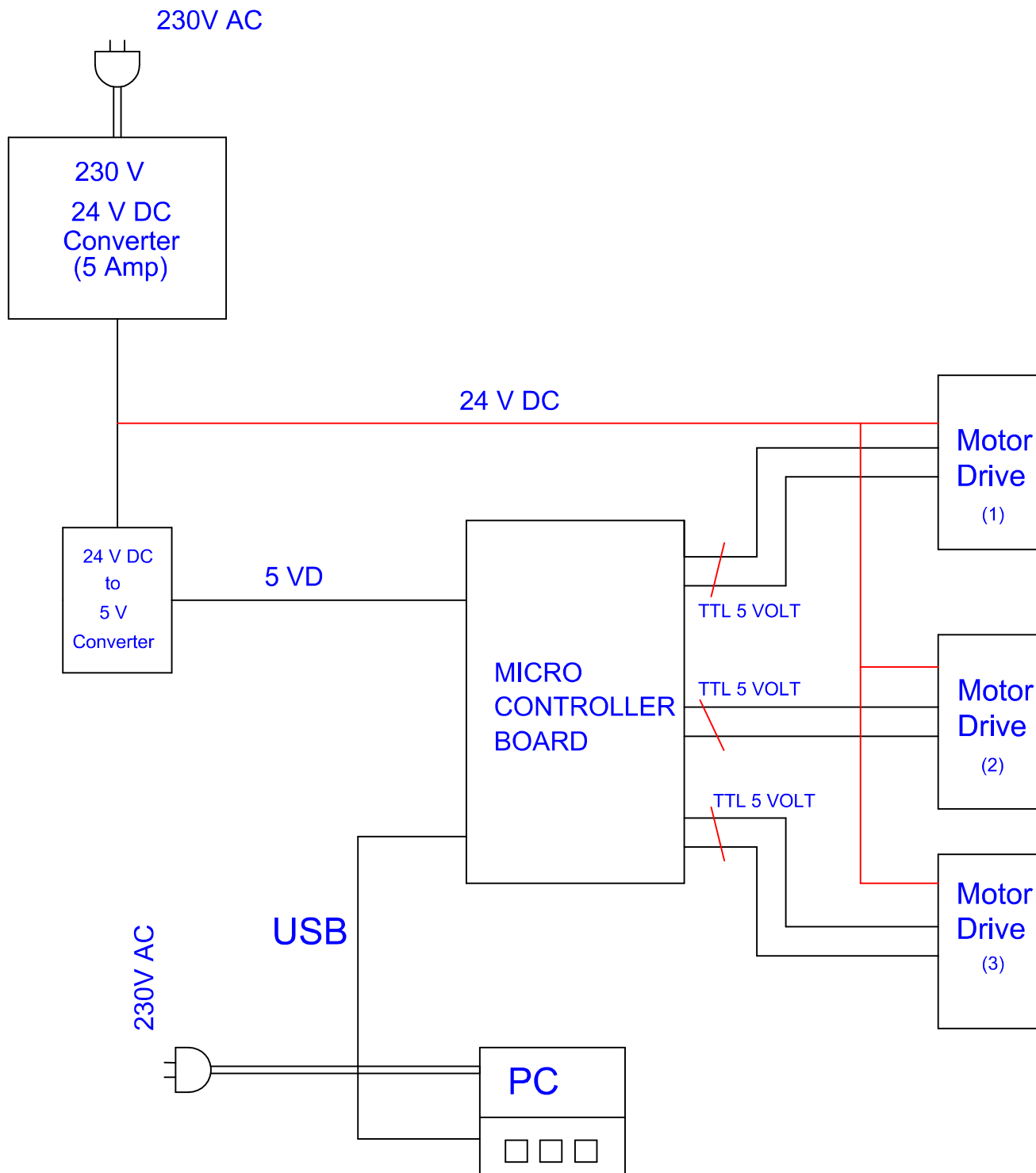

DRAWING NO.  
A4-DRHR-172-EPA-E02

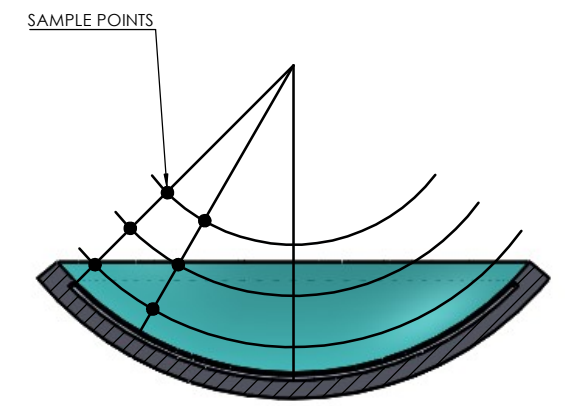
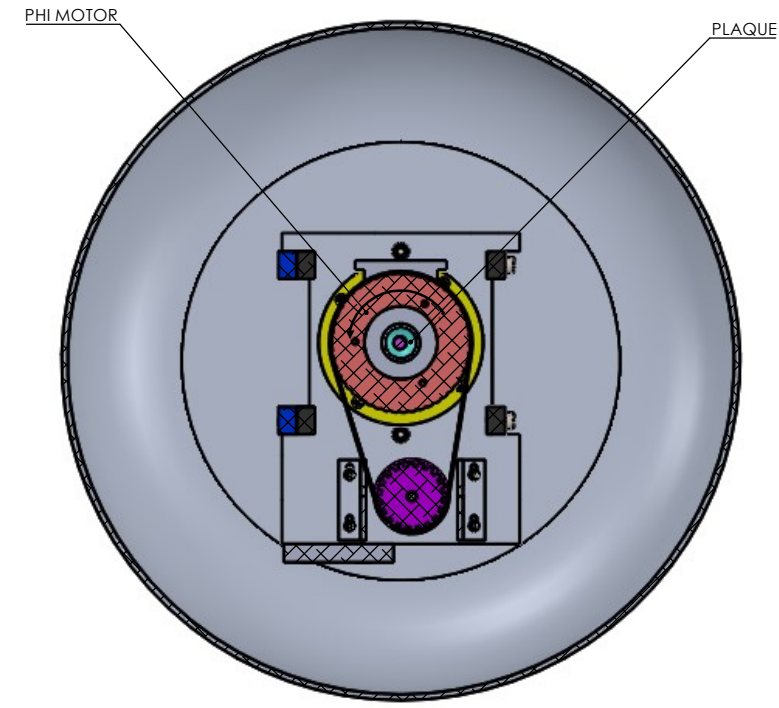
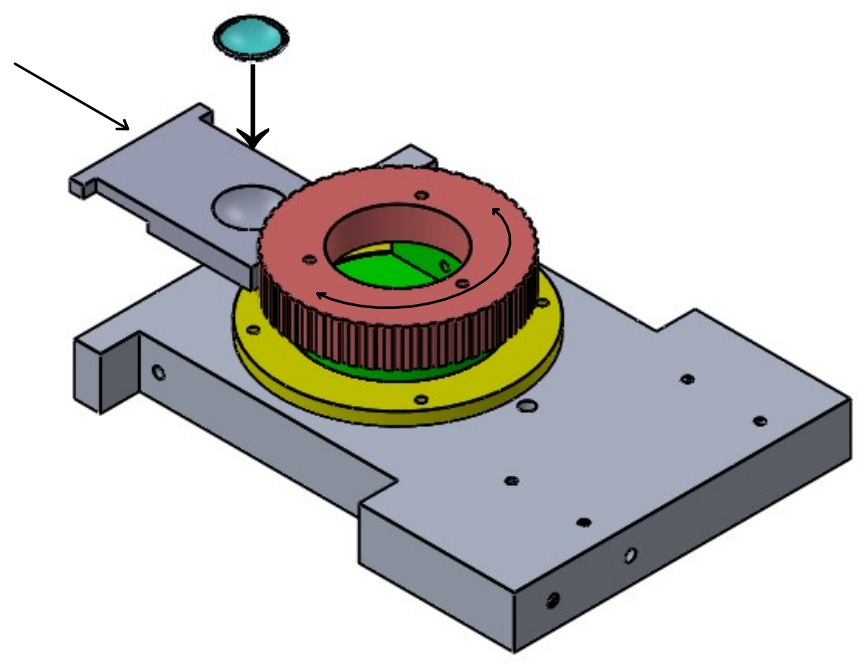
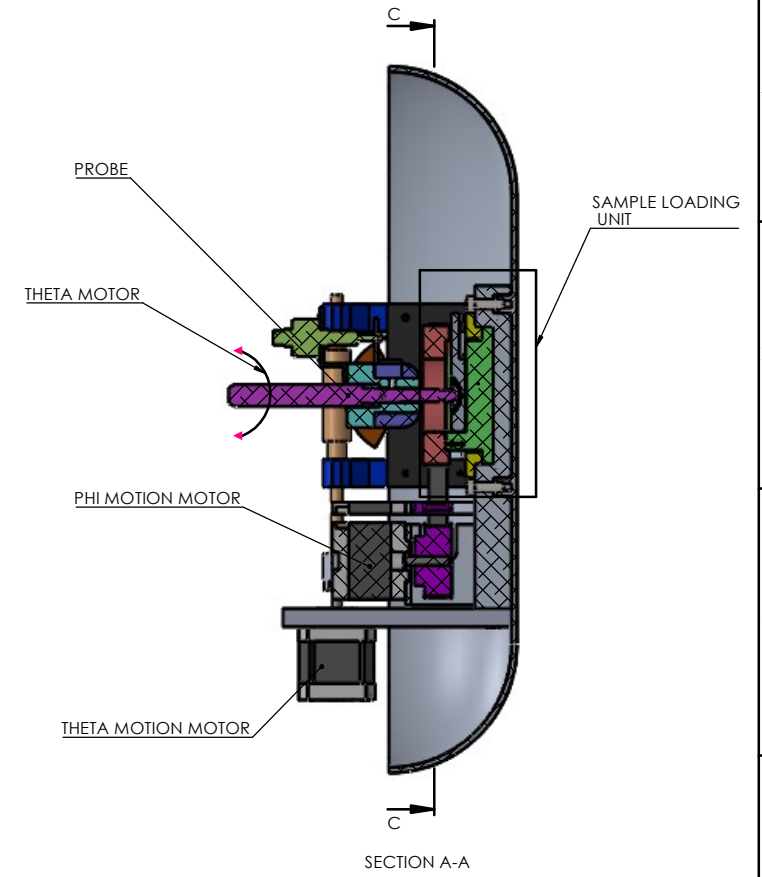
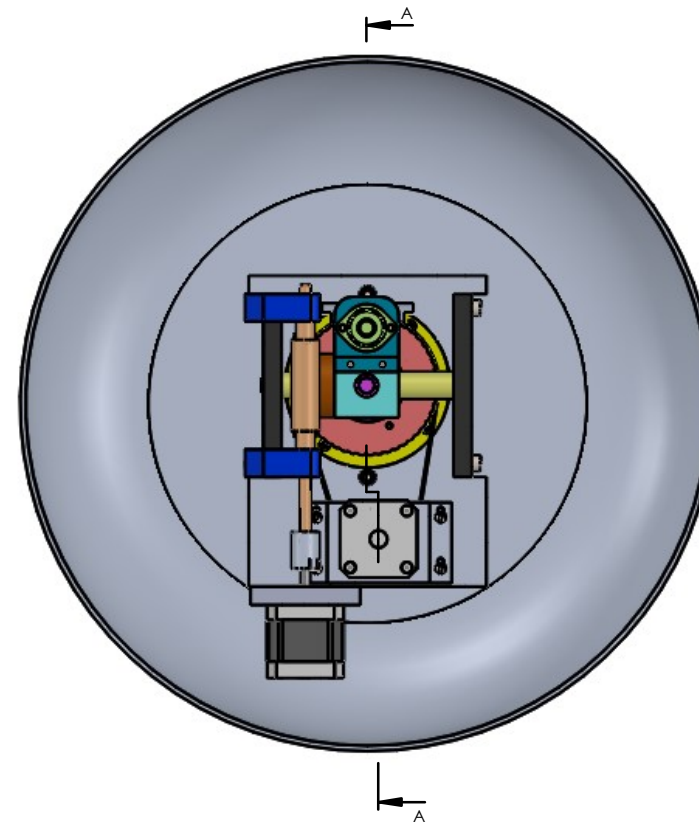
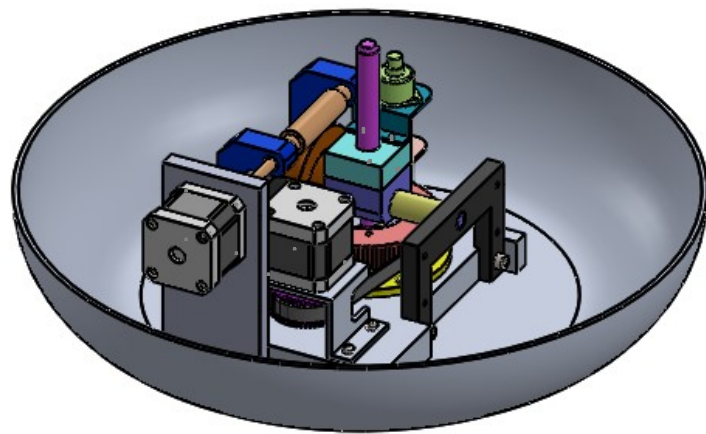

**SAMPLE LOADING UNIT**

**PHI MOTION**

ESTIMATED DIMENSION EYE APPLICATOR RU-106/RH-106

THIS DESIGN AND DRAWING IS THE PROPERTY OF BHABHA ATOMIC RESEARCH CENTRE AND SHALL BE RETURNED WITH QUOTATION UPON DELIVERY OF MATERIAL AND EQUIPMENT AND MUST NOT BE USED EXCEPT BY PERMISSION OF THE OWNER.

A1-DRHR/187/SPB/3.0

ITEM NO.	PART NUMBER	DESCRIPTION	QTY.
1	base Plate	A4-DSEA-DRHR-2021-2022-351	1
2	rotary Holder	A4-DSEA-DRHR-2021-2022-354	1
3	bearing Cover	A4-DSEA-DRHR-2021-2022-353	1
4	eye plaque	A4-DSEA-DRHR-2021-2022-355	1
5	plaque Holder	A4-DSEA-DRHR-2021-2022-352	1
6	timing PULLEY 1	A4-DSEA-DRHR-2021-2022-356	1

SR.NO	REFERENCE DRAWING	DRAWINGS NOS.	NO.	LOC.	DESCRIPTION	DRX. DATE	APPR. DATE

NOTES :-  
 UNLESS OTHERWISE SPECIFIED  
 1) ALL DIMENSIONS ARE IN mm.  
 2) DO NOT SCALE THE DRAWING.  
 3) SURFACE FINISH IN MICRON 3.2 CLA OR BETTER.  
 4) ROUND ALL INTERNAL SHARP CORNERS BY 0.4R  
 5) REMOVE ALL EXTERNAL SHARP CORNERS BY CHAMFER 0.5x45°.

GENERAL TOLERANCES UNLESS OTHERWISE SPECIFIED SHOULD CONFORM TO IS: 2102 (MEDIUM CLASS).

DIMENSIONS	TOL.	DIMENSIONS	TOL.
UP TO 6	+0.1	215-1000	+0.8
6-30	+0.2	1000-2000	+1.2
30-120	+0.3	2000-4000	+2.0
120-315	+0.5	4000-8000	+3.0

RADII AND CHAMFERS	0.5-3	3-6	6-30
TOLERANCE	+0.2	+0.5	+1.0

PROJECT	EYE PLAQUE	TITLE	ASSEMBLY
DRAWN BY	DATE	04-05-2022	APPROVED
DRG. CHKD.	DATE		
DESIGNED BY	DES.CHKD.		PROJECTION
GOVERNMENT OF INDIA		FILE NAME	SCALE 1:1
BHABHA ATOMIC RESEARCH CENTRE		DRAWING NO.	REV. 0
DIVISION OF REMOTE HANDLING & ROBOTICS		A1-DSEA/DRHR/2021-22/100	

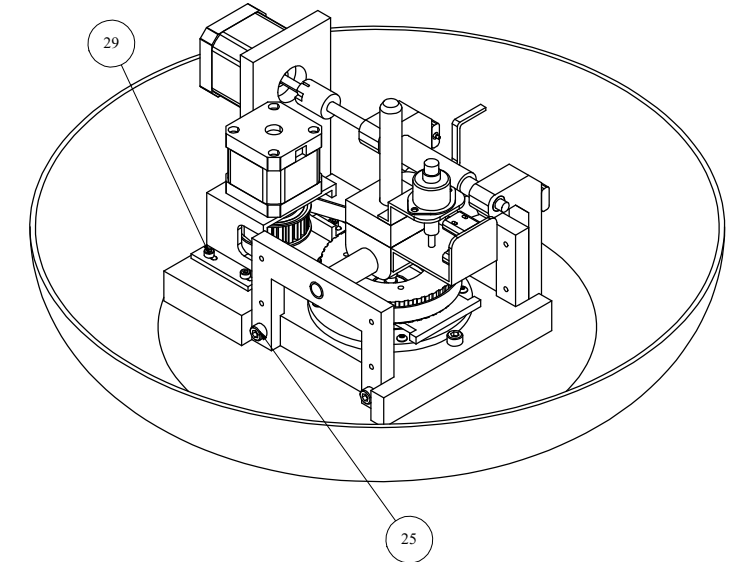
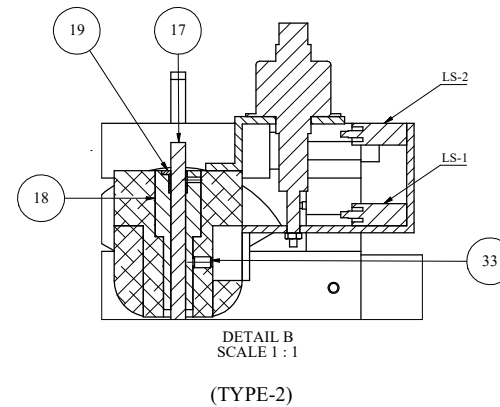
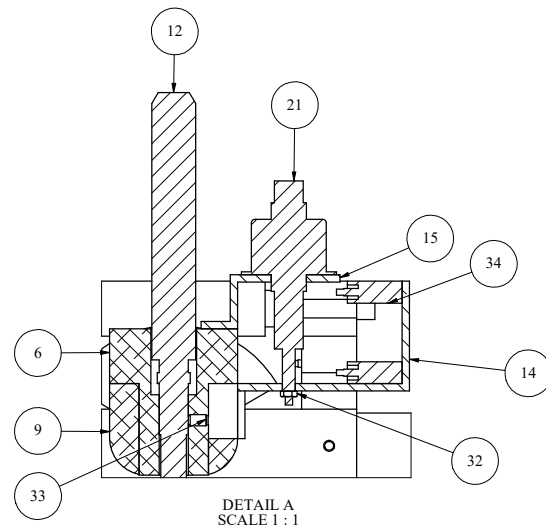
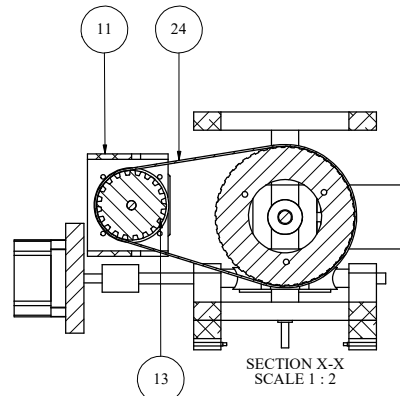
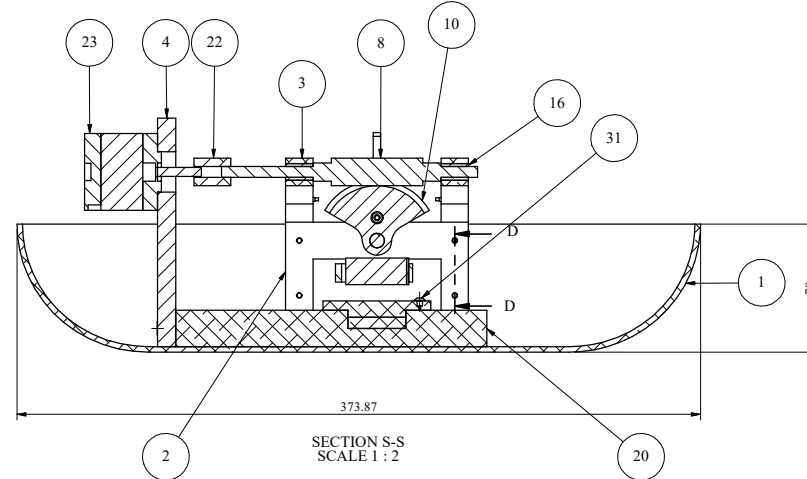
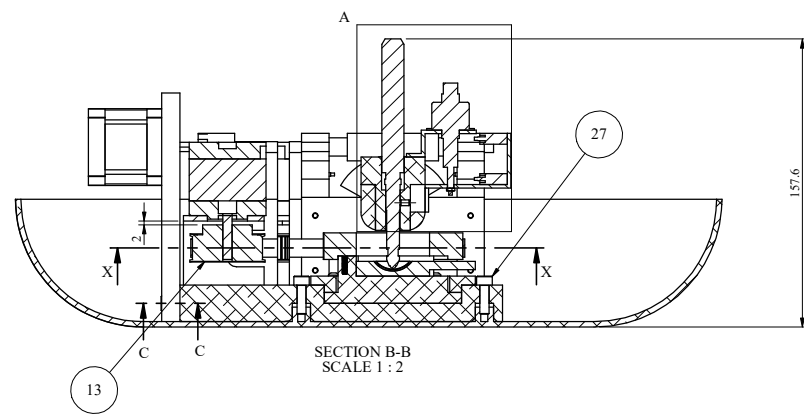
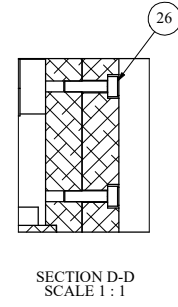
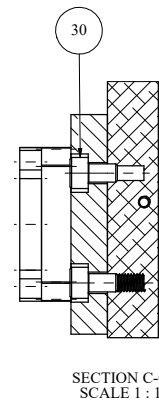
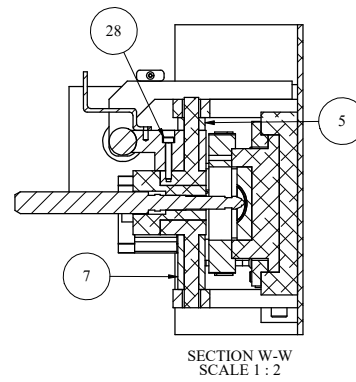
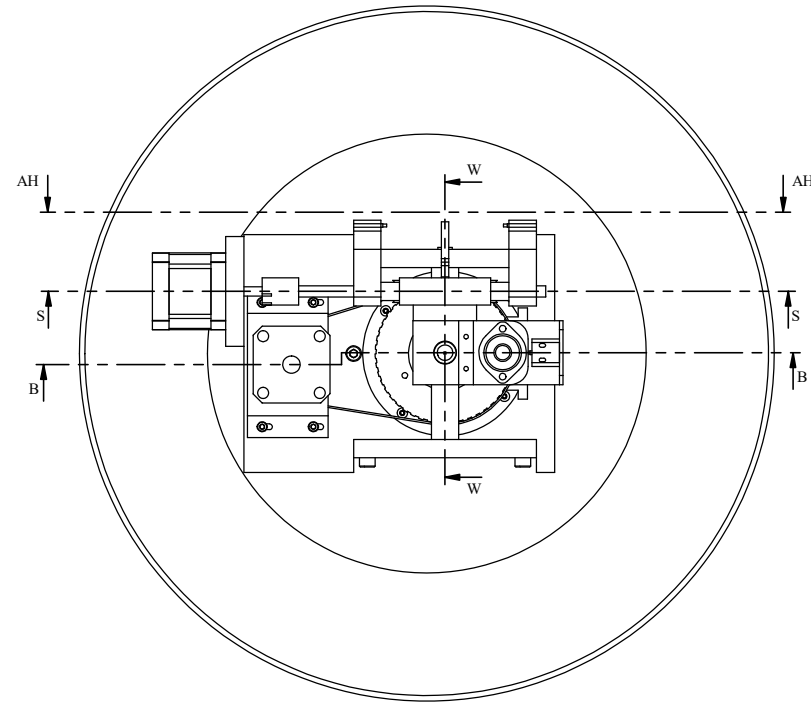

ITEM NO.	PART NAME	MATL.	DRAWING NO./DESCRIPTION	QTY.	REMARKS
1	WATER BOWL	AL6061	A3-DSEA-DRHR-2021-2022-301	1	
2	U BRACKET	AL6061	A3-DSEA-DRHR-2021-2022-302	2	
3	WORM SUPPORT	AL6061	A4-DSEA-DRHR-2021-2022-303	2	
4	WORM MOTOR BRACKET	AL6061	A4-DSEA-DRHR-2021-2022-304	1	
5	TILT SPACER SHORT	SS 304	A4-DSEA-DRHR-2021-2022-305	1	
6	DETECTOR HOLDER	AL6061	A4-DSEA-DRHR-2021-2022-306	1	
7	TILT SPACER	AL6061	A4-DSEA-DRHR-2021-2022-307	1	
8	WORM	BRONZE	A4-DSEA-DRHR-2021-2022-308	1	
9	TILT HOLDER	AL6061	A4-DSEA-DRHR-2021-2022-309	1	
10	SECTOR GEAR	SS304	A4-DSEA-DRHR-2021-2022-310	1	
11	TIMING PULLEY BRACKET	AL6061	A4-DSEA-DRHR-2021-2022-311	1	
12	SLIM HEAD LINEAR GAUGE	STD	A4-DSEA-DRHR-2021-2022-312	1	
13	TIMING BELT PULLEY 2	AL6061	A4-DSEA-DRHR-2021-2022-313	1	
14	SUPPORT PLATE	AL6061	A4-DSEA-DRHR-2021-2022-314	1	
15	SUPPORT PLATE 2	AL6061	A4-DSEA-DRHR-2021-2022-315	1	
16	BUSH	BRASS	A4-DSEA-DRHR-2021-2022-316	2	
17*	RADIATION DETECTOR	SS 304	A4-DSEA-DRHR-2021-2022-317	1	
18	ADAPTOR	AL6061	A4-DSEA-DRHR-2021-2022-318	1	
19	SLEEVE	SS 304	A4-DSEA-DRHR-2021-2022-319	1	
20	BASE PLATE SUB-ASSY	-	A3-DSEA-DRHR-2021-2022-350	1	
21	STEPPER LINEAR ACTUATORS	STD	PORTESCAP (MOD-20DAM10DIB-K)	1	
22	FLEXIBLE COUPLING	AL6061	(ID-6MM,OD-15MM,HEIGHT-20MM)	1	
23	NEMA17_40mm	STD	BHOLANATH (MOD-BH42SH38-1684A)	2	
24	BELT	RUBBER	(PITCH-5MM,WIDTH-9MM,LENTH-360MM)	1	
25	B18.3.1M - 5 X 0.8 X 12 HEX SHCS -- 12NHX	STD	STD	4	
26	B18.3.1M - 3 X 0.5 X 12 HEX SHCS -- 12NHX	STD	STD	4	
27	B18.3.1M - 5 X 0.8 X 16 HEX SHCS -- 16NHX	STD	STD	2	
28	B18.3.1M - 3 X 0.5 X 20 HEX SHCS -- 20NHX	STD	STD	1	
29	B18.3.1M - 3 X 0.5 X 5 HEX SHCS -- 5NHX	STD	STD	4	
30	B18.3.1M - 5 X 0.8 X 8 HEX SHCS -- 8NHX	STD	STD	2	
31	B18.3.4M - 3 X 0.5 X 3 SBHCS --N	STD	STD	4	
32	B18.2.4.1M - HEX NUT, STYLE 1, M2 X 0.4 --D-N	STD	STD	1	
33	B18.3.6M - M3 X 0.5 X 5 HEX SOCKET FLAT PT. SS --N	STD	STD	1	
34	LIMIT SWITCH	STD	STD	4	

\* NOT IN THE SCOPE OF SUPPLY

THIS DESIGN AND DRAWING IS THE PROPERTY OF BHABHA ATOMIC RESEARCH CENTRE AND SHALL BE RETURNED WITH QUOTATION OR UPON DELIVERY OF MATERIAL AND EQUIPMENT AND MUST NOT BE USED EXCEPT BY PERMISSION OF THE OWNER.

REV 0  
A1-DSEA/DRHR/2021-22/300

SR.NO.	REFERENCE DRAWING	DRAWINGS NOS.	NO.	LOC.	DESCRIPTION	DRX. DATE	APPR. DATE

NOTES -  
UNLESS OTHERWISE SPECIFIED  
1) ALL DIMENSIONS ARE IN mm.  
2) DO NOT SCALE THE DRAWING.  
3) SURFACE FINISH IN MICRON 3.2 CLA OR BETTER.  
4) ROUND ALL INTERNAL SHARP CORNERS BY 0.4R  
5) REMOVE ALL EXTERNAL SHARP CORNERS BY CHAMFER 0.5x45°.

GENERAL TOLERANCES UNLESS OTHERWISE SPECIFIED SHOULD CONFORM TO IS: 2102 (MEDIUM CLASS).			
DIMENSIONS	TOL.	DIMENSIONS	TOL.
UP TO 6	±0.1	215-1000	±0.8
6-30	±0.2	1000-2000	±1.2
30-120	±0.3	2000-4000	±2.0
120-315	±0.5	4000-8000	±3.0
RADI AND CHAMFERS			
0.5-3	3-6	6-30	
TOLERANCE			
±0.2	±0.5	±1.0	

PROJECT	DSEA	TITLE	DSEA GA ASSY	
DRAWN BY	AKSHAY	DATE	13.05.2022	APPROVED
DRG. CHKD.		DATE		
DESIGNED BY		DES. CHKD.		
		PROJECTION		
		FILE NAME	SCALE	1:1
		DRAWING NO.	A1-DSEA/DRHR/2021-22/300	REV. 0

1 2 3 4 5 6 7 8 9 10 11 12

A B C D E F G H

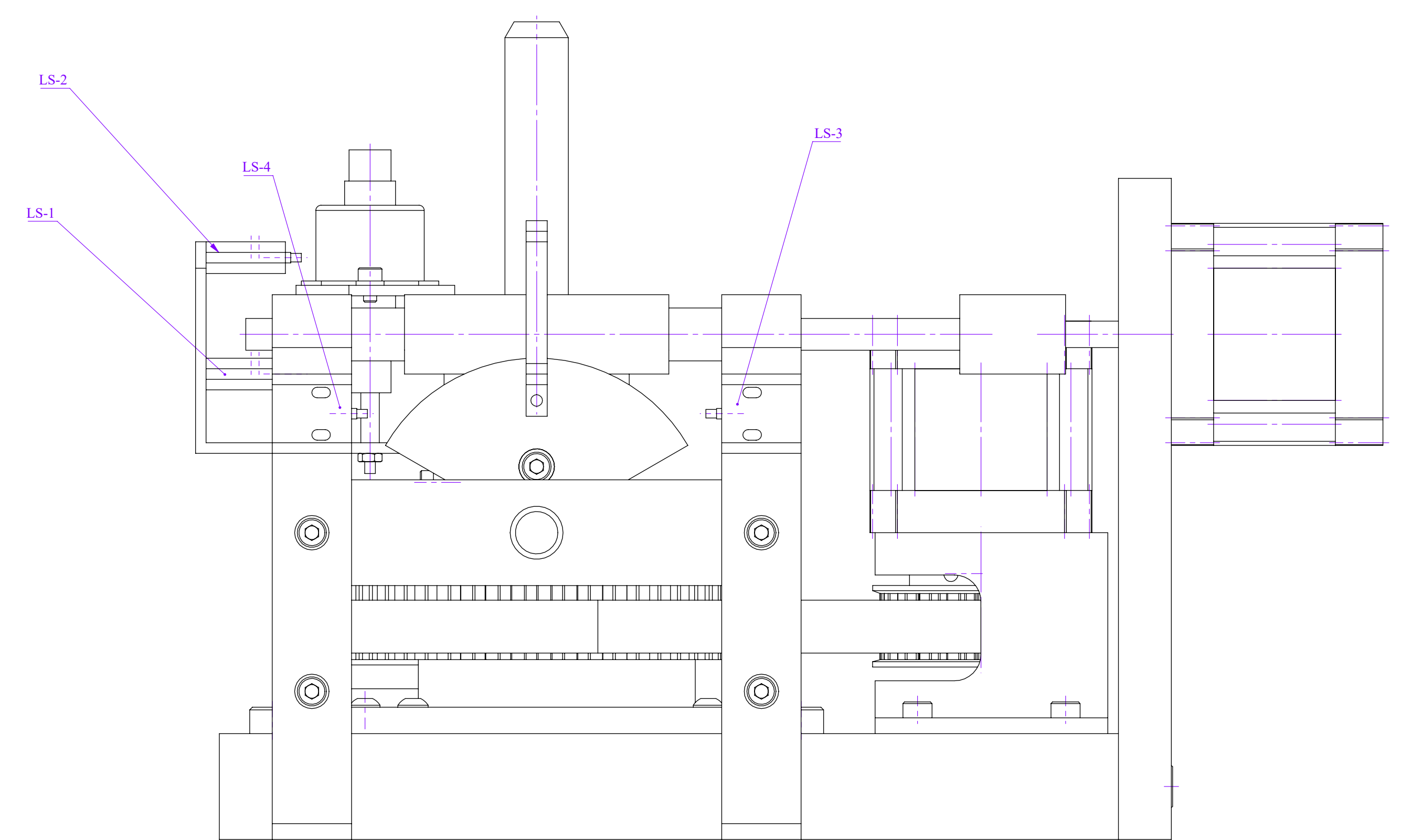
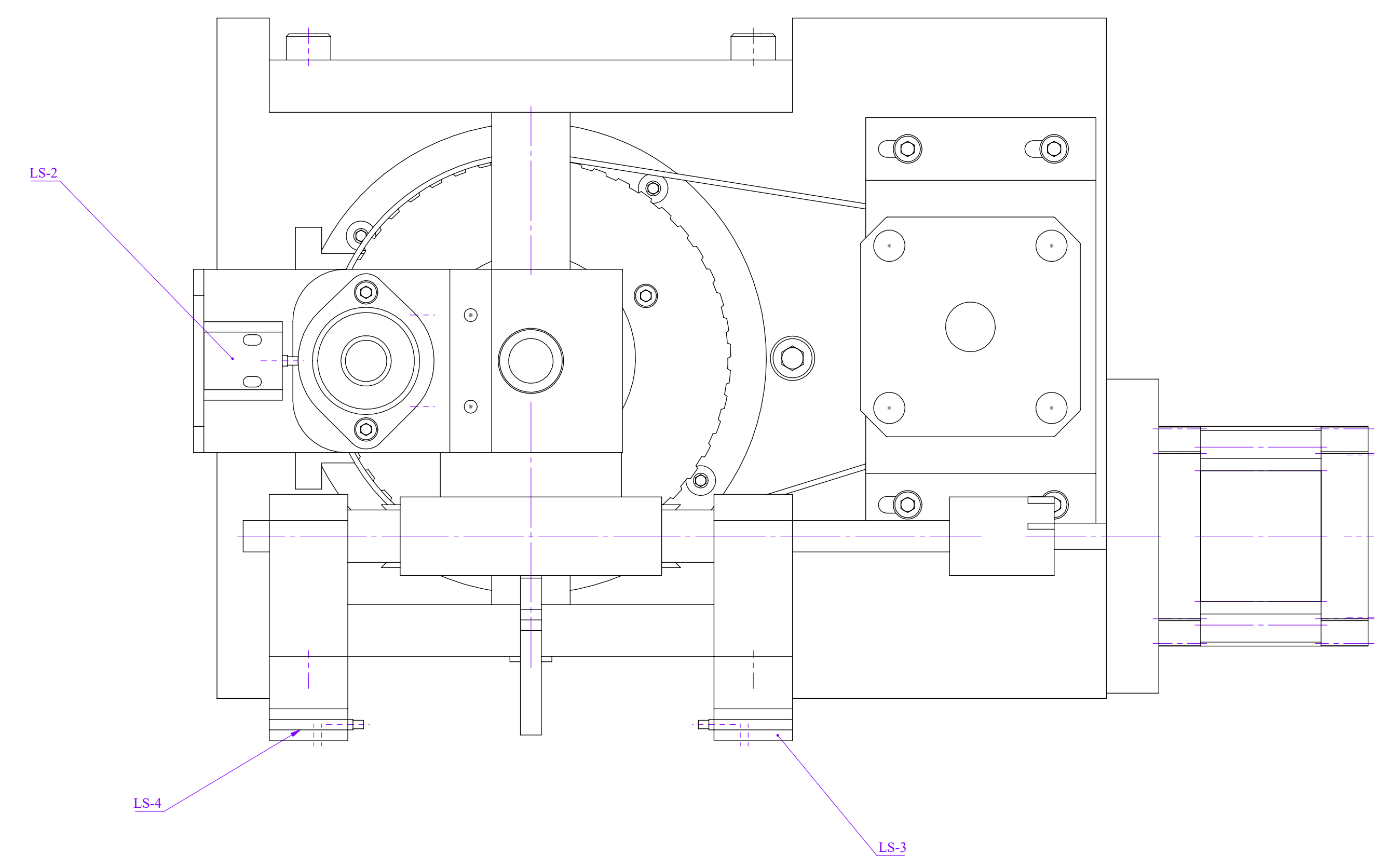
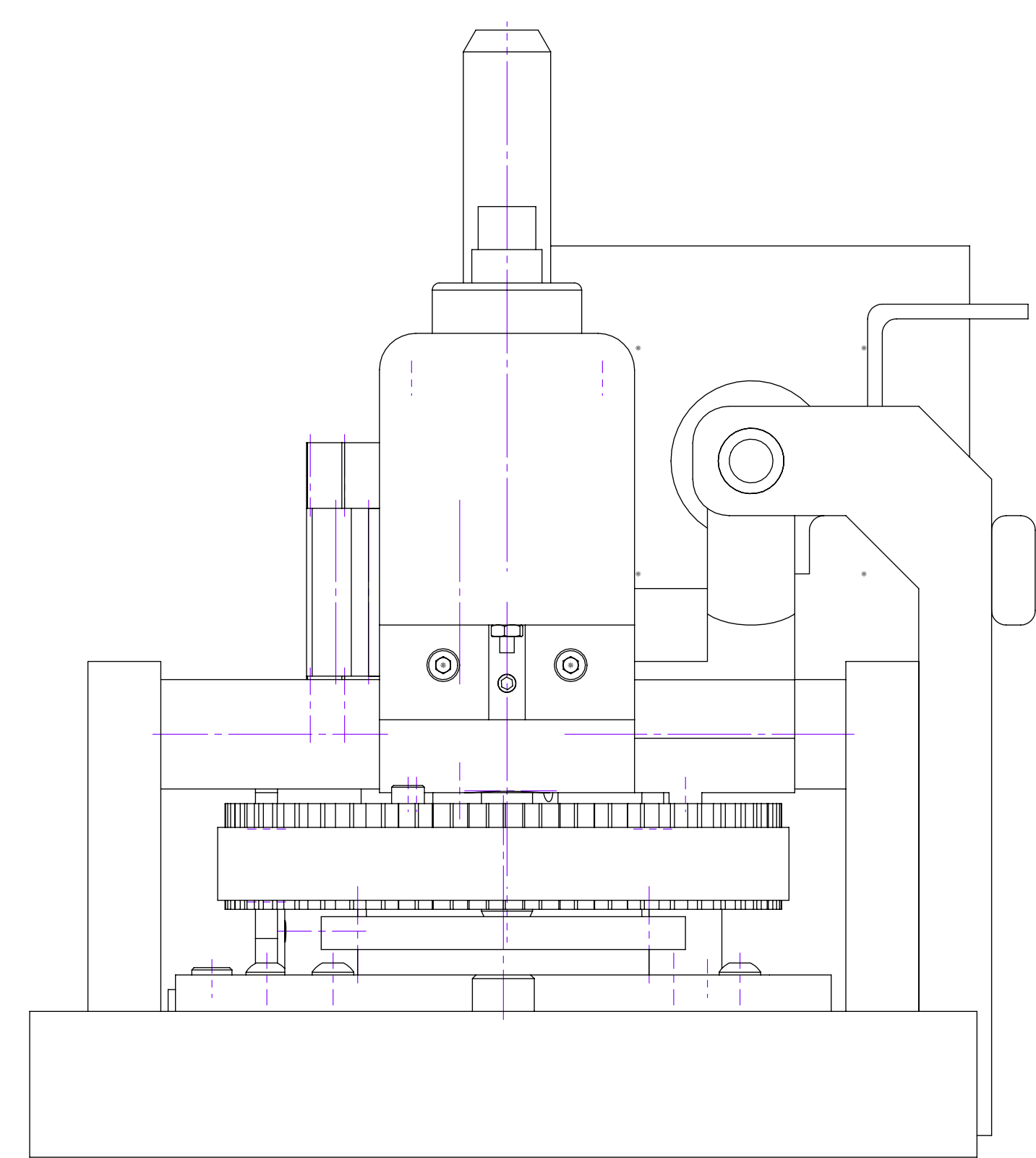

SECTION AH-AH  
SCALE 2 : 1.5

NOTE: LS - X : Limit Switch no .X

THIS DESIGN AND DRAWING IS THE PROPERTY OF BHABHA ATOMIC RESEARCH CENTRE AND SHALL BE RETURNED WITH NOTATION OR UPON DELIVERY OF MATERIAL AND EQUIPMENT AND MUST NOT BE USED EXCEPT BY PERMISSION OF THE OWNER.

A1-DSEA/DRHR/2021-22/300

REV: 0

SR.NO.	REFERENCE DRAWING	DRAWINGS NOS.	NO.	LOC.	DESCRIPTION	DRN. DATE	APPD. DATE

NOTES :-  
UNLESS OTHERWISE SPECIFIED  
1) ALL DIMENSIONS ARE IN mm.  
2) DO NOT SCALE THE DRAWING.  
3) SURFACE FINISH IN MICRON 3.2 CLA OR BETTER.  
4) ROUND ALL INTERNAL SHARP CORNERS BY 0.4R  
5) REMOVE ALL EXTERNAL SHARP CORNERS BY CHAMFER 0.5x45°.

GENERAL TOLERANCES UNLESS OTHERWISE SPECIFIED SHOULD CONFORM TO IS: 2102 (MEDIUM CLASS).

DIMENSIONS	TOL.	DIMENSIONS	TOL.
UP TO 6	+0.1	315-1000	+0.8
6-30	+0.2	1000-2000	+1.2
30-120	+0.3	2000-4000	+2.0
120-315	+0.5	4000-8000	+3.0

RADI AND CHAMFERS	0.5-3	3-6	6-30
TOLERANCE	+0.2	+0.5	+1.0

PROJECT	DSEA	TITLE	DSEA GA LS locations	
DRAWN BY	AKSHAY	DATE	13.05.2022	APPROVED
DRG. CHKD.		DATE		
DESIGNED BY		DES.CHKD.		PROJECTION
GOVERNMENT OF INDIA <b>BHABHA ATOMIC RESEARCH CENTRE</b> DIVISION OF REMOTE HANDLING & ROBOTICS			FILE NAME	SCALE 1:1
			DRAWING NO.	REV.
			A1-DSEA/DRHR/2021-22/300-LS	0

1 2 3 4 5 6 7 8 9 10 11 12

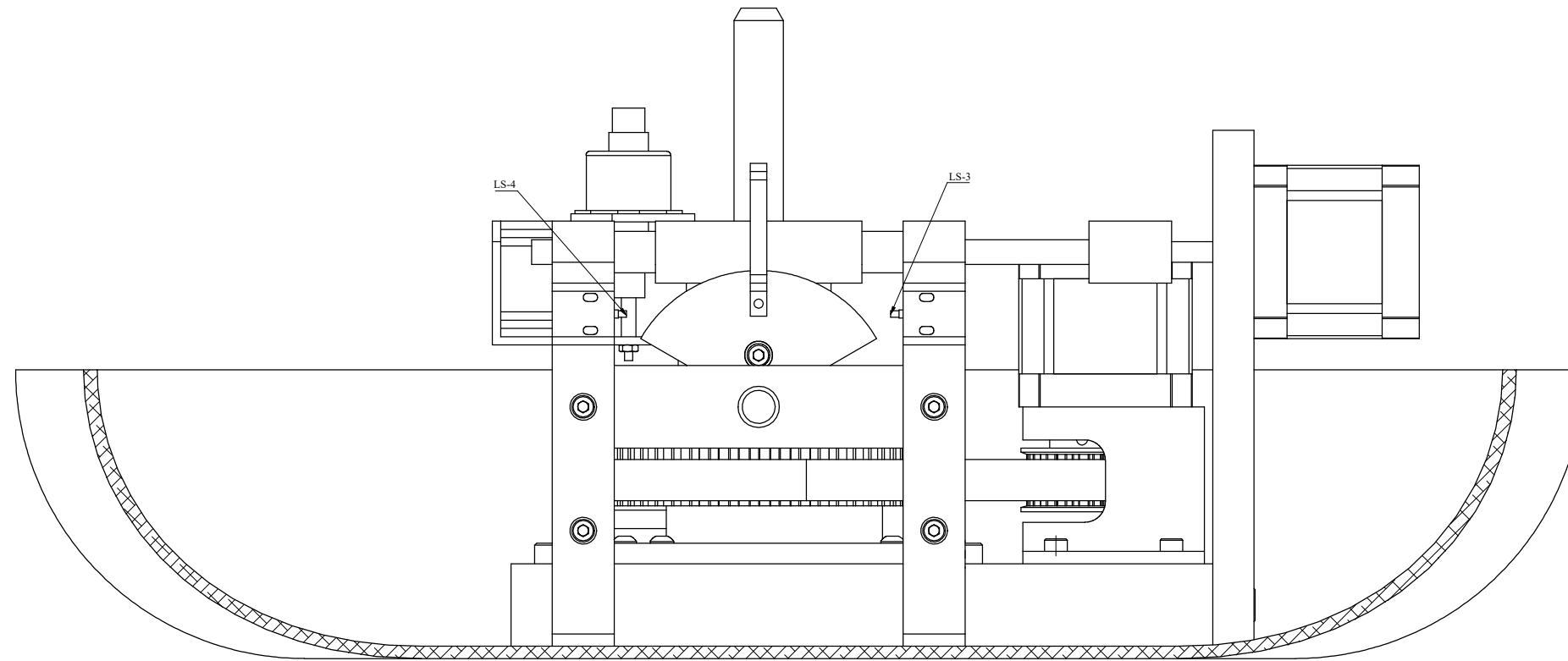

SECTION AH-AH  
SCALE 2 : 1.5

THIS DESIGN AND DRAWING IS THE PROPERTY OF BHABHA ATOMIC RESEARCH CENTRE AND SHALL BE RETURNED WITH QUOTATION OR UPON DELIVERY OF MATERIAL AND EQUIPMENT AND MUST NOT BE USED EXCEPT BY PERMISSION OF THE OWNER.

A1-DSEA/DRHR/2021-22/300

REV 0

SR.NO.	REFERENCE DRAWING	DRAWINGS NOS.	NO.	LOC.	DESCRIPTION	DRN. DATE	APPR. DATE

NOTES :-  
UNLESS OTHERWISE SPECIFIED  
1) ALL DIMENSIONS ARE IN mm.  
2) DO NOT SCALE THE DRAWING.  
3) SURFACE FINISH IN MICRON 3.2 CLA OR BETTER.  
4) ROUND ALL INTERNAL SHARP CORNERS BY 0.4R  
5) REMOVE ALL EXTERNAL SHARP CORNERS BY CHAMFER 0.5x45°.

GENERAL TOLERANCES UNLESS OTHERWISE SPECIFIED SHOULD CONFORM TO IS: 2102 (MEDIUM CLASS).

DIMENSIONS	TOL.	DIMENSIONS	TOL.
UP TO 6	±0.1	215-1000	±0.8
6-30	±0.2	1000-2000	±1.2
30-120	±0.3	2000-4000	±2.0
120-315	±0.5	4000-8000	±3.0

RADII AND CHAMFERS	0.5-3	3-6	6-30
TOLERANCE	±0.2	±0.5	±1.0

PROJECT	DSEA	TITLE	DSEA GA ASSY	
DRAWN BY	AKSHAY	DATE	13.05.2022	APPROVED
DRG. CHKD.		DATE		
DESIGNED BY		DES.CHKD.		PROJECTION
GOVERNMENT OF INDIA		FILE NAME	A1-DSEA/	SCALE 1:1
BHABHA ATOMIC RESEARCH CENTRE		DIVISION OF REMOTE HANDLING & ROBOTICS	DRHR/2021-22/300-LS-2	REV. 0



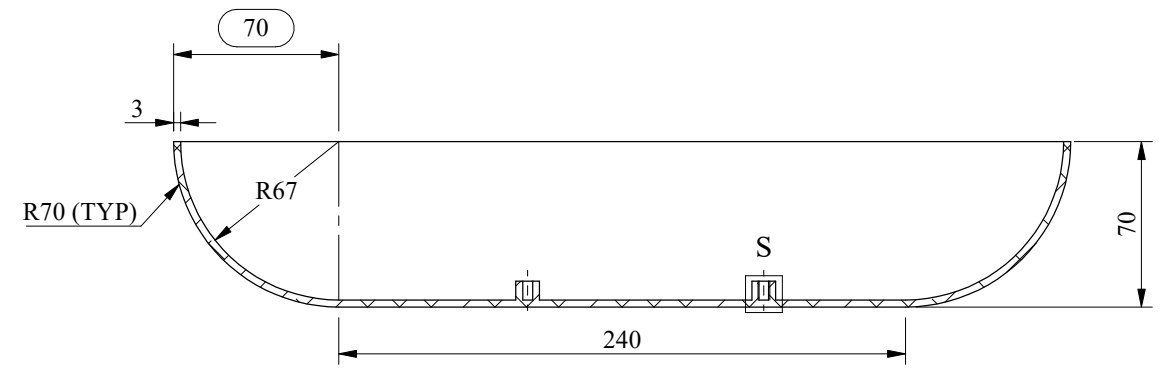
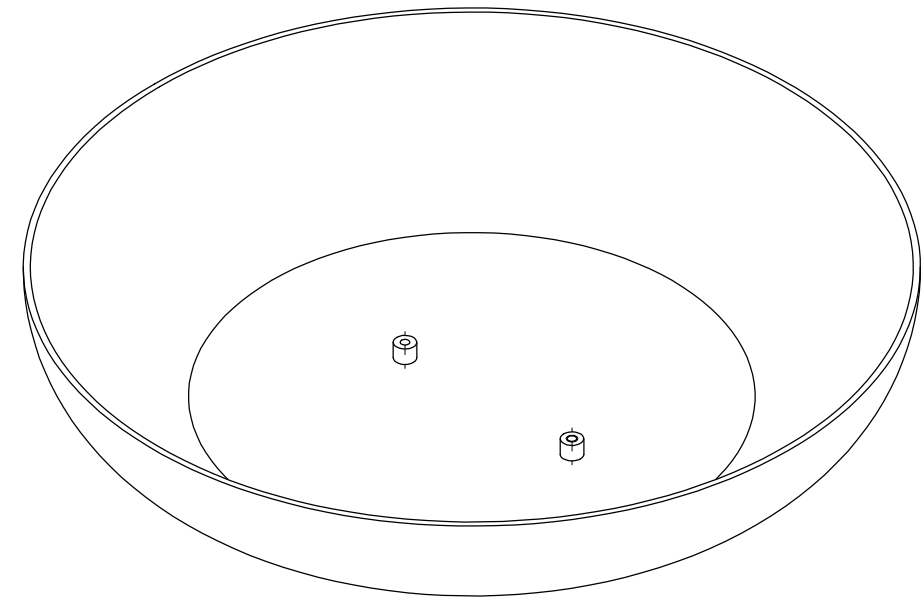
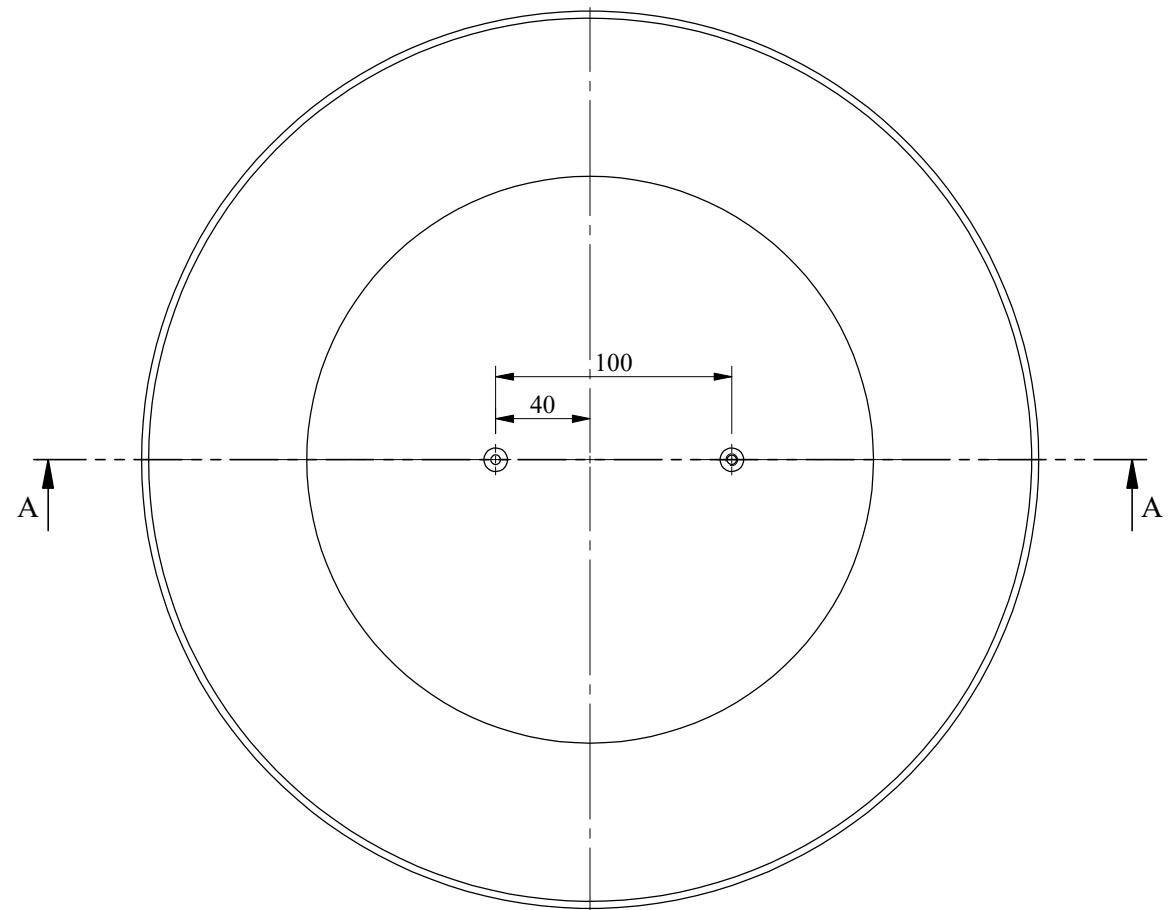

SECTION A-A  
SCALE 1 : 3

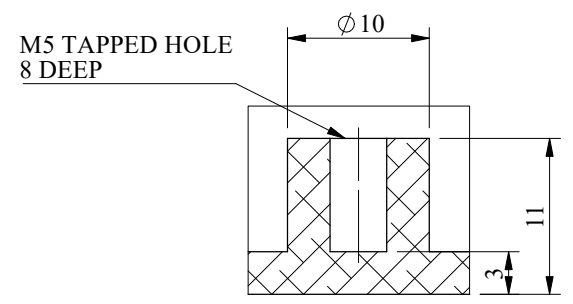

DETAIL S  
SCALE 2 : 1

PART NO.	1
MATL.	AL 6061
QTY./ASSY.	1

NOTES :-  
UNLESS OTHERWISE SPECIFIED  
1) ALL DIMENSIONS ARE IN mm.  
2) DO NOT SCALE THE DRAWING.  
3) SURFACE FINISH IN MICRON 3.2 CLA OR BETTER.  
4) ROUND ALL INTERNAL SHARP CORNERS BY 0.4R  
5) REMOVE ALL EXTERNAL SHARP CORNERS BY CHAMFER 0.5x45°  
6) GENERAL TOLERANCE AS PER IS:2102 (MEDIUM CLASS).

PROJECT	DSEA	TITLE	WATER BOWL	
DRAWN BY	AKSHAY	DATE	27.12.2021	APPROVED
DRG. CHKD.		DATE		
DESIGNED BY		DES.CHKD.		PROJECTION
			FILE NAME	SCALE 1:1
			DRAWING NO.	REV.
			A3-DSEA/DRHR/2021-22/301	0

NO.	LOC.	DESCRIPTION	DRN. DATE	APPD. DATE
1	-	-	-	-
REVISIONS				

1 2 3 4 5 6 7 8

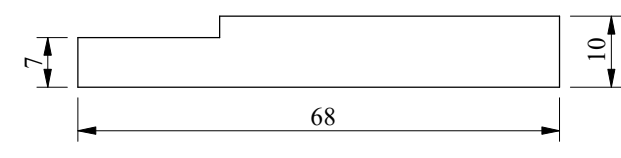
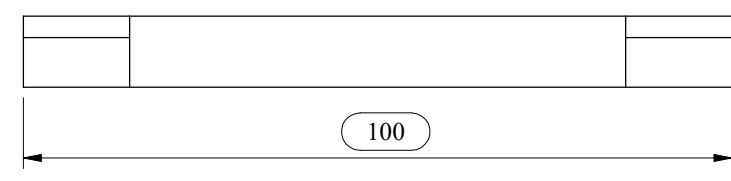
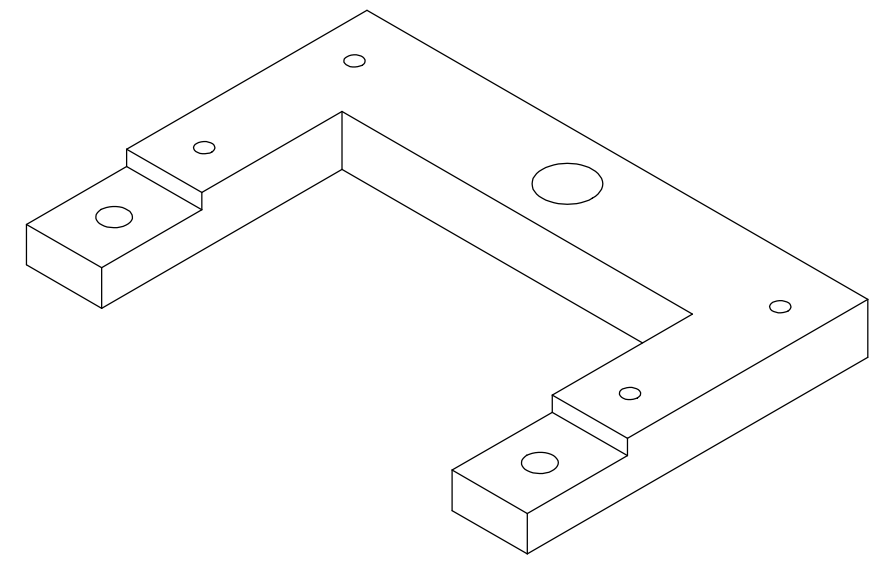
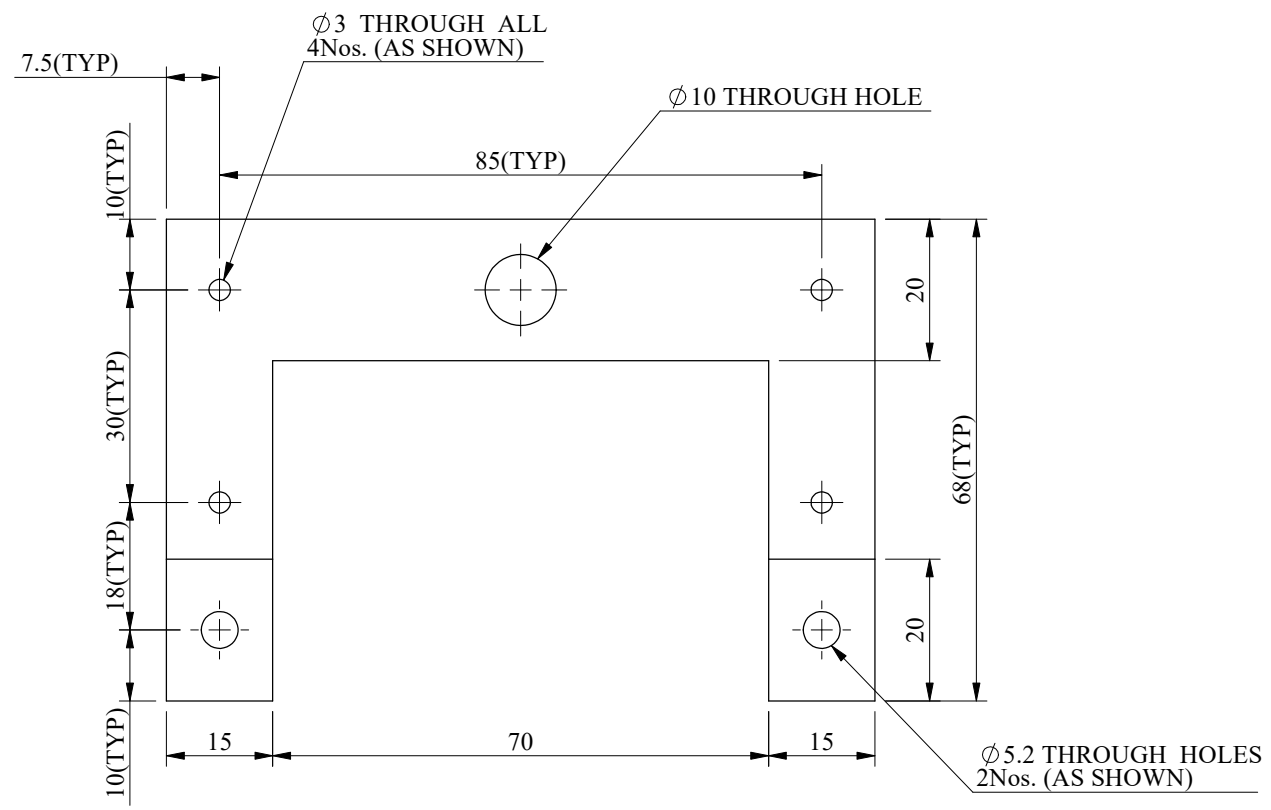

PART NO.	2
MATL.	AL 6061
QTY./ASSY.	2

NOTES :-  
 UNLESS OTHERWISE SPECIFIED  
 1) ALL DIMENSIONS ARE IN mm.  
 2) DO NOT SCALE THE DRAWING.  
 3) SURFACE FINISH IN MICRON 3.2 CLA OR BETTER.  
 4) ROUND ALL INTERNAL SHARP CORNERS BY 0.4R.  
 5) REMOVE ALL EXTERNAL SHARP CORNERS BY CHAMFER 0.5x45°  
 6) GENERAL TOLERANCE AS PER IS:2102 (MEDIUM CLASS).

PROJECT	DSEA	TITLE	U BRACKET	
DRAWN BY	AKSHAY	DATE	28.12.2021	APPROVED
DRG. CHKD.		DATE		
DESIGNED BY		DES.CHKD.		PROJECTION
			FILE NAME	SCALE 1:1
			DRAWING NO.	REV. 0
			A3-DSEA/DRHR/2021-22/302	

NO.	LOC.	DESCRIPTION	DRN. DATE	APPD. DATE
1	-	-	-	-
REVISIONS				

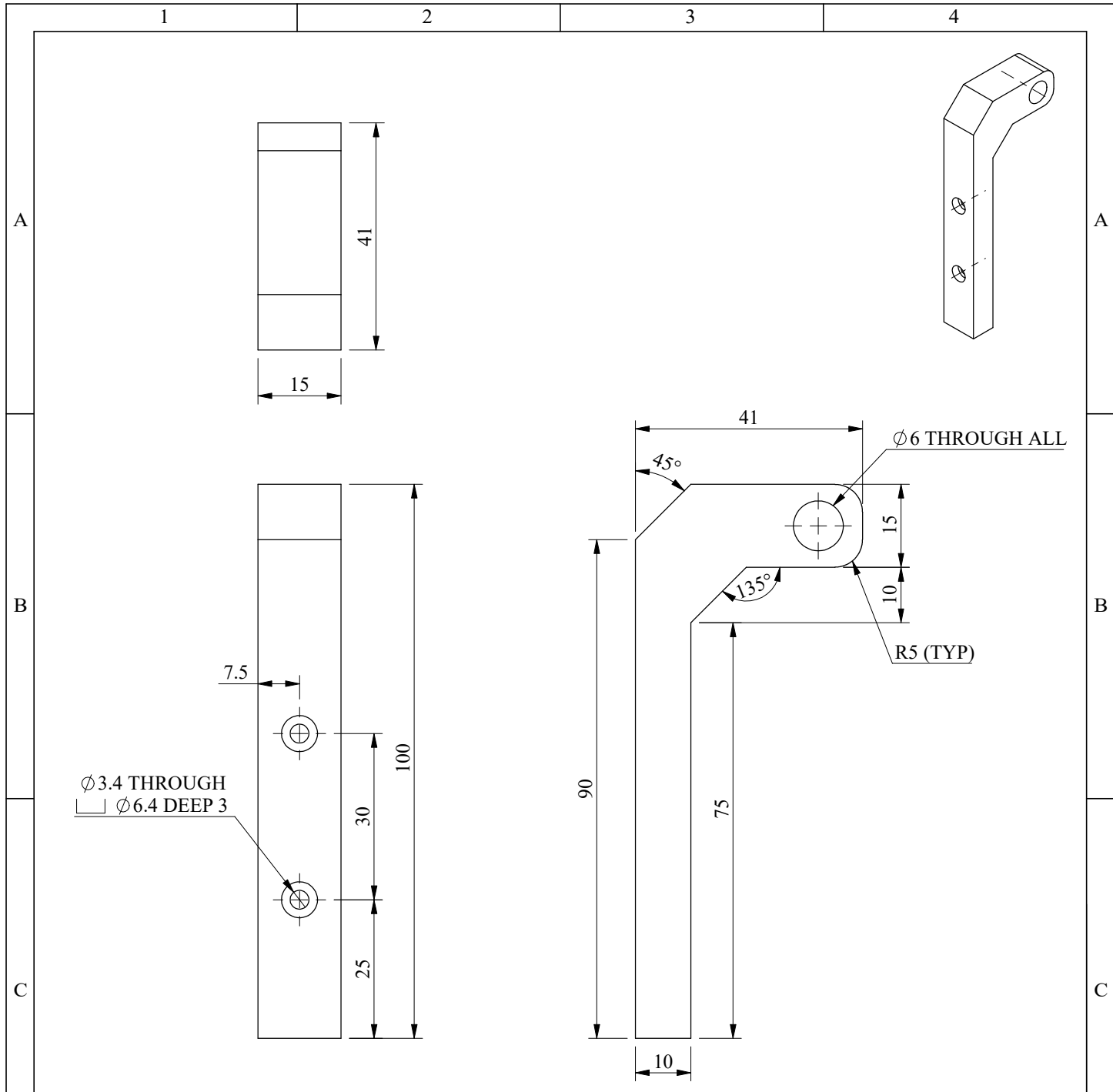

NOTES :-  
 UNLESS OTHERWISE SPECIFIED  
 1) ALL DIMENSIONS ARE IN mm.  
 2) DO NOT SCALE THE DRAWING.  
 3) SURFACE FINISH IN MICRON 3.2 CLA OR BETTER.  
 4) ROUND ALL INTERNAL SHARP CORNERS BY 0.4R  
 5) REMOVE ALL EXTERNAL SHARP CORNERS BY CHAMFER 0.5x45°  
 6) GENERAL TOLERANCE AS PER IS:2102 (MEDIUM CLASS).

NO.	DESCRIPTION	DR'N DATE	APP'D
REVISIONS			
TITLE		APP'D	
<u>WORM SUPPORT</u>			
PART NO.	3	SCALE 1:2	
MAT'L	AL 6061		
QTY/ASS'Y	2	FILE NAME	
DR'N BY AKSHAY PROJECT : DSEA		DRG. NO.	
DRG. CHKD.		<b>A4-DSEA/DRHR/2021-22/303</b>	
DSE'D BY		REV. 0 DATE 28.12.2021	
DES.CHKD.			

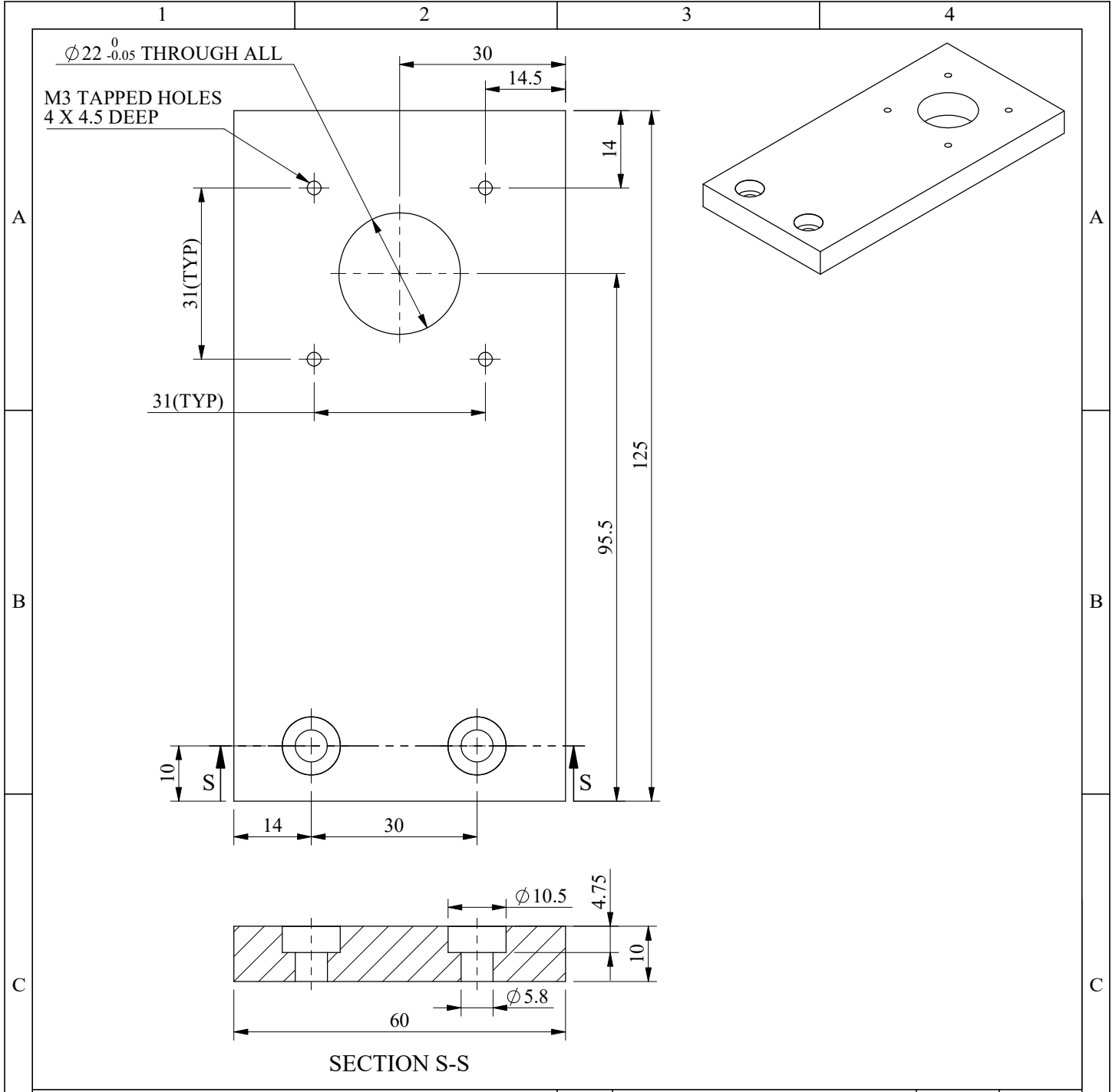

SECTION S-S

NOTES :-

- UNLESS OTHERWISE SPECIFIED
- 1) ALL DIMENSIONS ARE IN mm.
- 2) DO NOT SCALE THE DRAWING.
- 3) SURFACE FINISH IN MICRON 3.2 CLA OR BETTER.
- 4) ROUND ALL INTERNAL SHARP CORNERS BY 0.4R
- 5) REMOVE ALL EXTERNAL SHARP CORNERS BY CHAMFER 0.5x45°
- 6) GENERAL TOLERANCE AS PER IS:2102 (MEDIUM CLASS).

NO.	DESCRIPTION	DR'N DATE	APP'D
REVISIONS			
TITLE WORM MOTOR BRACKET		APP'D	
PART NO.	4	SCALE 1:2	
MAT'L	AL 6061		
QTY/ASS'Y	1	FILE NAME -	
DR'N BY AKSHAY		DRG. NO.	
PROJECT : DSEA		<b>A4-DSEA/DRHR/2021-22/304</b>	
DRG. CHKD.		REV. 0 DATE 28.12.2021	
DSE'D BY			
DES.CHKD.			

D

D

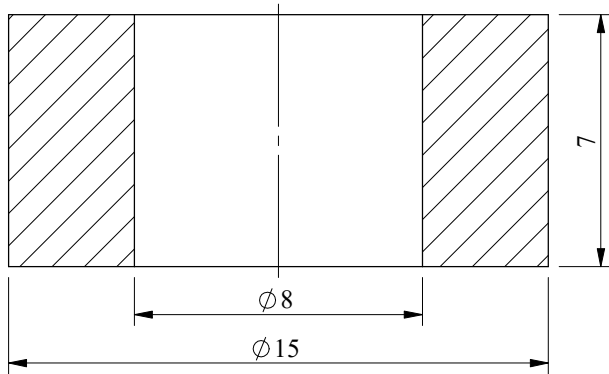
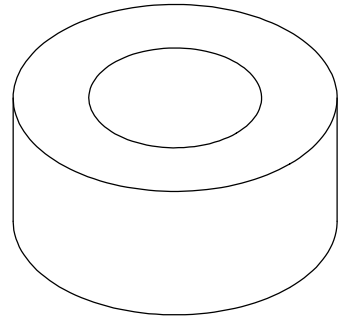
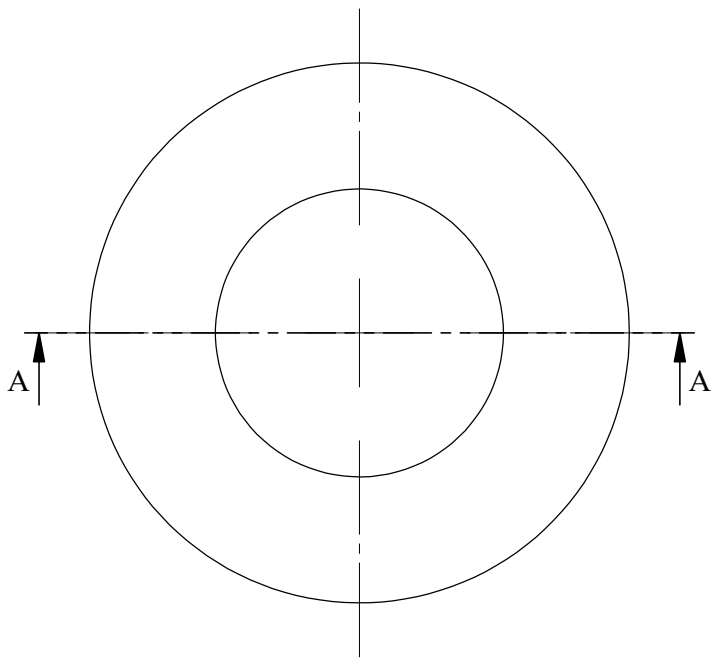

SECTION A-A

NOTES :-

UNLESS OTHERWISE SPECIFIED

- 1) ALL DIMENSIONS ARE IN mm.
- 2) DO NOT SCALE THE DRAWING.
- 3) SURFACE FINISH IN MICRON 3.2 CLA OR BETTER.
- 4) ROUND ALL INTERNAL SHARP CORNERS BY 0.4R
- 5) REMOVE ALL EXTERNAL SHARP CORNERS BY CHAMFER 0.5x45°
- 6) GENERAL TOLERANCE AS PER IS:2102 (MEDIUM CLASS).

NO.	DESCRIPTION	DR'N DATE	APP'D
REVISIONS			
TITLE <b>TILT SPACER SHORT</b>		APP'D	
PART NO.	5	SCALE 1:2	DRG. NO. <b>A4-DSEA/DRHR/2021-22/305</b>
MAT'L	SS 304		
QTY/ASS'Y	1	FILE NAME -	
DR'N BY AKSHAY		PROJECT :DSEA	
DRG. CHKD.		REV. 0 DATE 28.12.2021	
DSE'D BY			
DES.CHKD.			

1

2

3

4

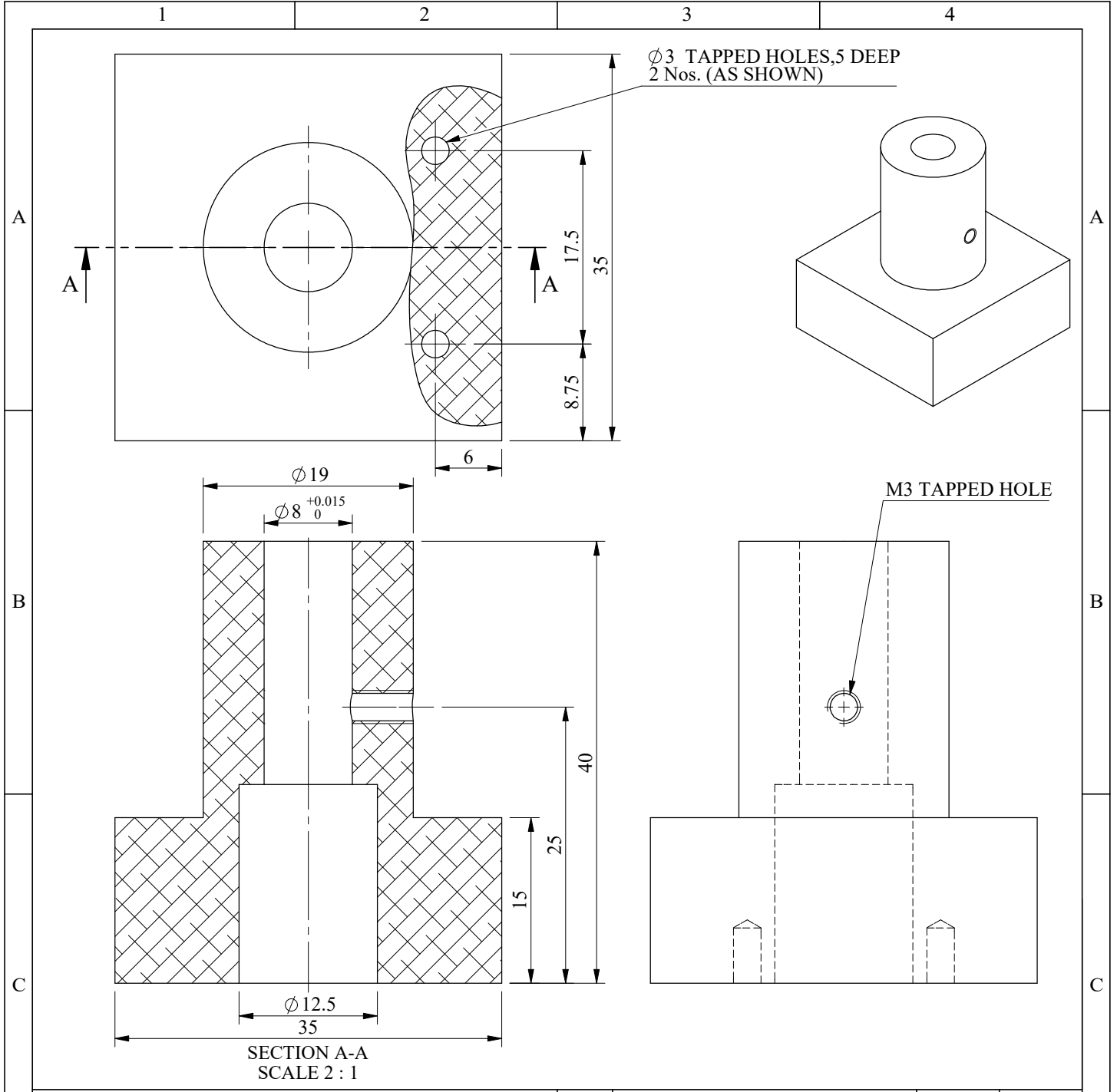

NOTES :-  
 UNLESS OTHERWISE SPECIFIED  
 1) ALL DIMENSIONS ARE IN mm.  
 2) DO NOT SCALE THE DRAWING.  
 3) SURFACE FINISH IN MICRON 3.2 CLA OR BETTER.  
 4) ROUND ALL INTERNAL SHARP CORNERS BY 0.4R  
 5) REMOVE ALL EXTERNAL SHARP CORNERS BY CHAMFER 0.5x45°  
 6) GENERAL TOLERANCE AS PER IS:2102 (MEDIUM CLASS).

NO.	DESCRIPTION	DR'N DATE	APP'D
REVISIONS			
TITLE <b>DETECTOR HOLDER</b>		APP'D	
PART NO.	6	SCALE 1:2	
MAT'L	AL 6061		
QTY/ASS'Y	1	FILE NAME -	

DR'N BY	AKSHAY	PROJECT : DSEA	DRG. NO.
DRG. CHKD.			<b>A4-DSEA/DRHR/2021-22/306</b>
DSE'D BY			REV. 0 DATE 28.12.2021
DES.CHKD.			

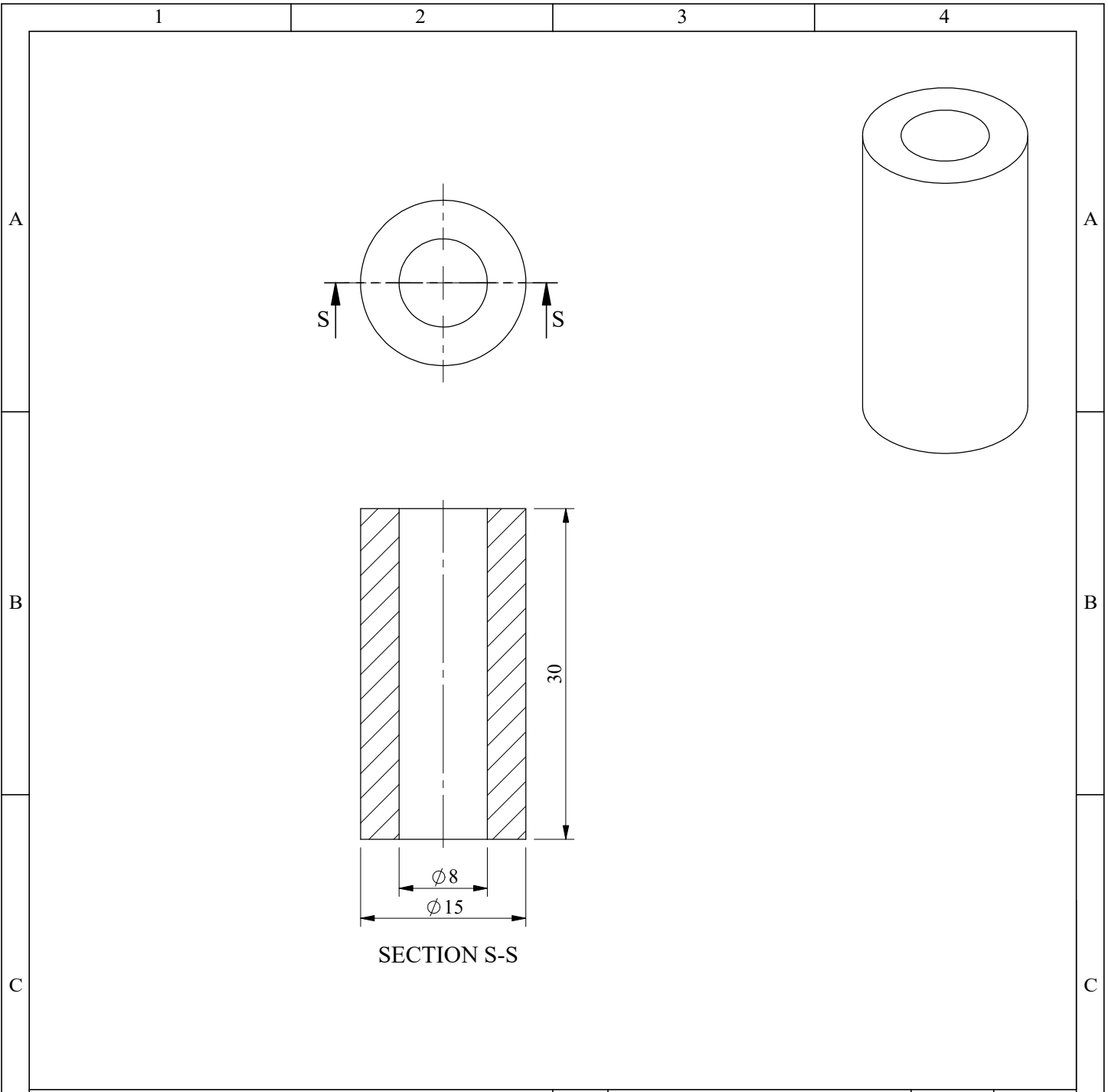

SECTION S-S

NOTES :-  
 UNLESS OTHERWISE SPECIFIED  
 1) ALL DIMENSIONS ARE IN mm.  
 2) DO NOT SCALE THE DRAWING.  
 3) SURFACE FINISH IN MICRON 3.2 CLA OR BETTER.  
 4) ROUND ALL INTERNAL SHARP CORNERS BY 0.4R  
 5) REMOVE ALL EXTERNAL SHARP CORNERS BY CHAMFER 0.5x45°  
 6) GENERAL TOLERANCE AS PER IS:2102 (MEDIUM CLASS).

NO.	DESCRIPTION	DR'N DATE	APP'D
REVISIONS			
TITLE <b>TILT SPACER</b>		APP'D	
PART NO.	7	SCALE 1:2	
MAT'L	AL 6061		
QTY/ASS'Y	1	FILE NAME -	

DR'N BY	AKSHAY	PROJECT : DSEA
DRG. CHKD.		
DSE'D BY		
DES.CHKD.		

DRG. NO.	<b>A4-DSEA/DRHR/2021-22/307</b>
REV. 0	DATE 28.12.2021

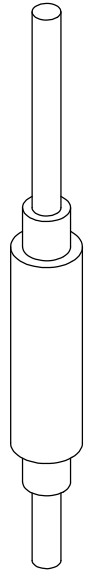
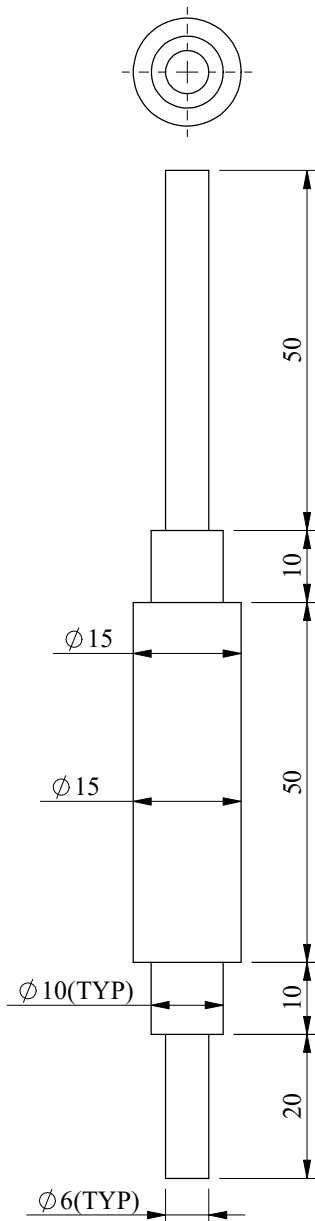

WORM DATA	
LEAD	-
NO.OF START	1
P.C.D.	15
THREAD	TRAPZOIS

NOTES :-  
 UNLESS OTHERWISE SPECIFIED  
 1) ALL DIMENSIONS ARE IN mm.  
 2) DO NOT SCALE THE DRAWING.  
 3) SURFACE FINISH IN MICRON 3.2 CLA OR BETTER.  
 4) ROUND ALL INTERNAL SHARP CORNERS BY 0.4R  
 5) REMOVE ALL EXTERNAL SHARP CORNERS BY CHAMFER 0.5x45°  
 6) GENERAL TOLERANCE AS PER IS:2102 (MEDIUM CLASS).

NO.	DESCRIPTION	DR'N DATE	APP'D
REVISIONS			
TITLE		APP'D	
<u>WORM</u>			
PART NO.	8	SCALE 1:2	
MAT'L	BRONZE		
QTY/ASS'Y	1	FILE NAME -	

DR'N BY	AKSHAY	PROJECT : DSEA	DRG. NO.
DRG. CHKD.			<b>A4-DSEA/DRHR/2021-22/308</b>
DSE'D BY			REV. 0 DATE 28.12.2021
DES.CHKD.			



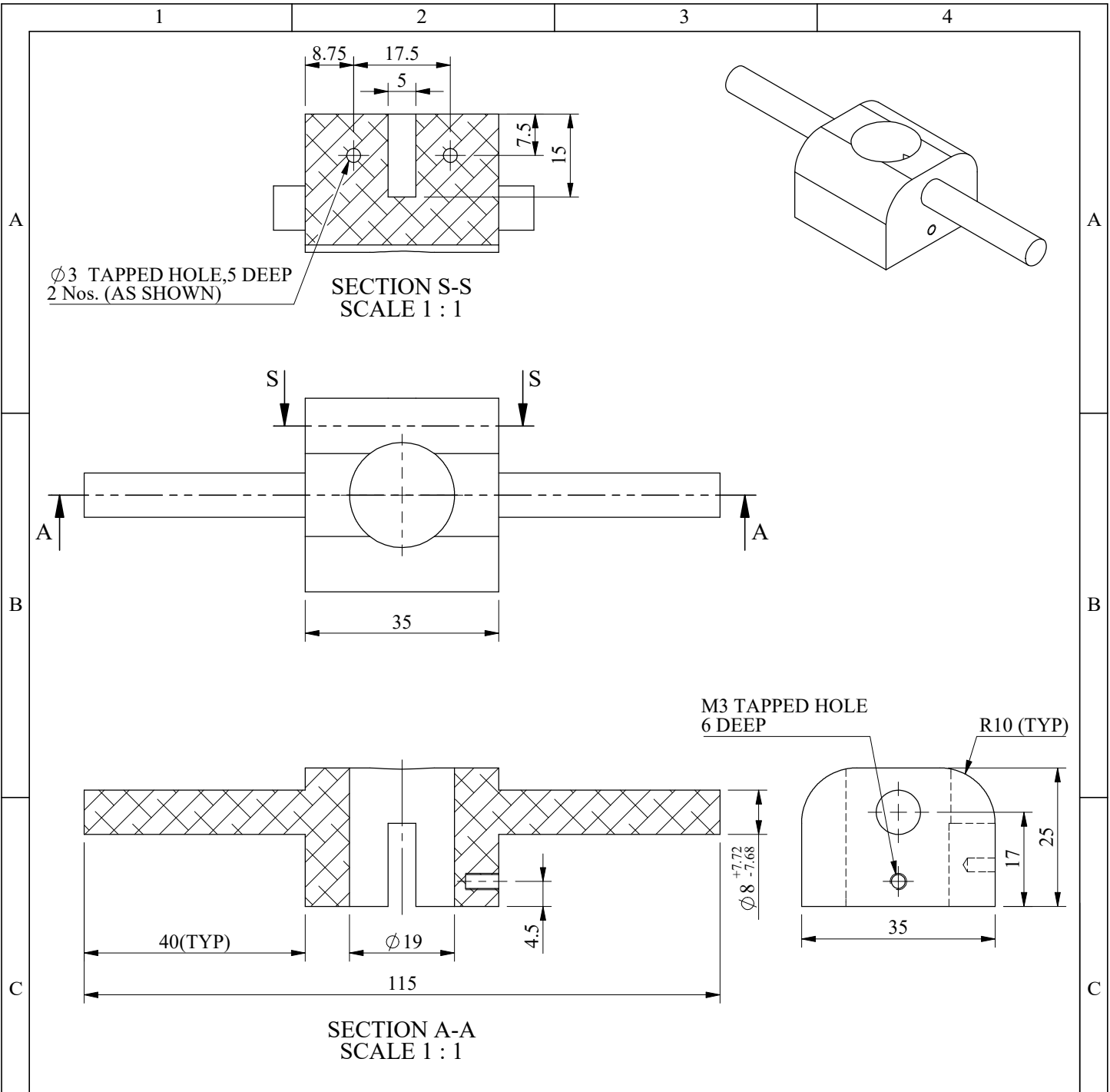

- NOTES :-  
 UNLESS OTHERWISE SPECIFIED  
 1) ALL DIMENSIONS ARE IN mm.  
 2) DO NOT SCALE THE DRAWING.  
 3) SURFACE FINISH IN MICRON 3.2 CLA OR BETTER.  
 4) ROUND ALL INTERNAL SHARP CORNERS BY 0.4R  
 5) REMOVE ALL EXTERNAL SHARP CORNERS BY CHAMFER 0.5x45°  
 6) GENERAL TOLERANCE AS PER IS:2102 (MEDIUM CLASS).

NO.	DESCRIPTION	DR'N DATE	APP'D
REVISIONS			
TITLE <b>TILT HOLDER</b>		APP'D	
PART NO.	9	SCALE 1:2	
MAT'L	AL 6061		
QTY/ASS'Y	1	FILE NAME -	

DR'N BY	AKSHAY	PROJECT : DSEA	DRG. NO.
DRG. CHKD.			<b>A4-DSEA/DRHR/2021-22/309</b>
DSE'D BY			REV. 0 DATE 28.12.2021
DES.CHKD.			

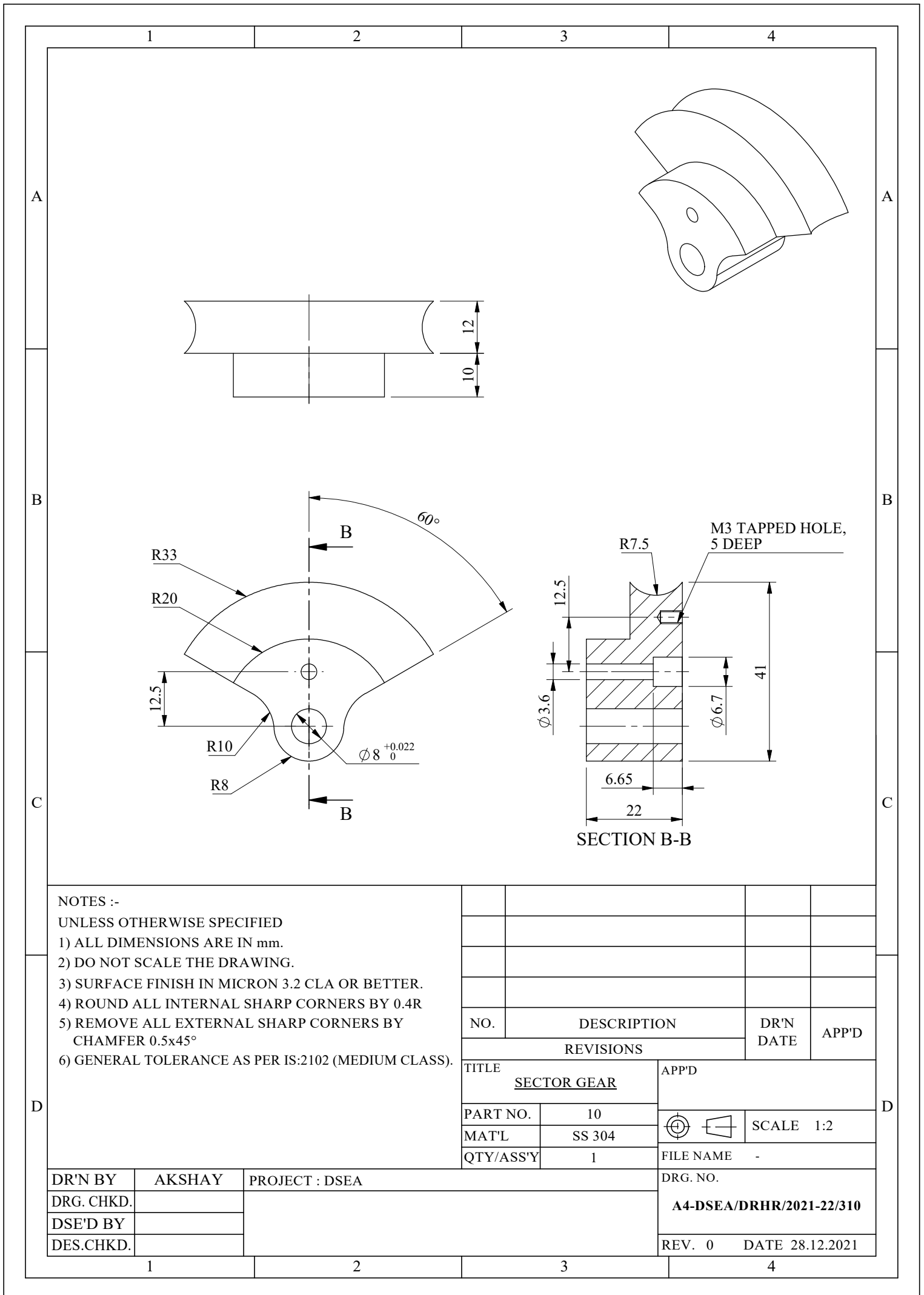

NOTES :-  
 UNLESS OTHERWISE SPECIFIED  
 1) ALL DIMENSIONS ARE IN mm.  
 2) DO NOT SCALE THE DRAWING.  
 3) SURFACE FINISH IN MICRON 3.2 CLA OR BETTER.  
 4) ROUND ALL INTERNAL SHARP CORNERS BY 0.4R  
 5) REMOVE ALL EXTERNAL SHARP CORNERS BY CHAMFER 0.5x45°  
 6) GENERAL TOLERANCE AS PER IS:2102 (MEDIUM CLASS).

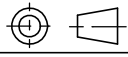
NO.	DESCRIPTION	DR'N DATE	APP'D
REVISIONS			
TITLE <b>SECTOR GEAR</b>		APP'D	
PART NO.	10	 SCALE 1:2	
MAT'L	SS 304		
QTY/ASS'Y	1	FILE NAME -	
DR'N BY AKSHAY		DRG. NO.	
PROJECT : DSEA		<b>A4-DSEA/DRHR/2021-22/310</b>	
DRG. CHKD.		REV. 0 DATE 28.12.2021	
DSE'D BY			
DES.CHKD.			

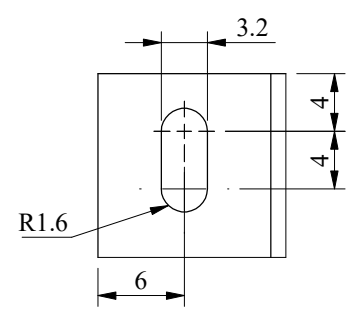
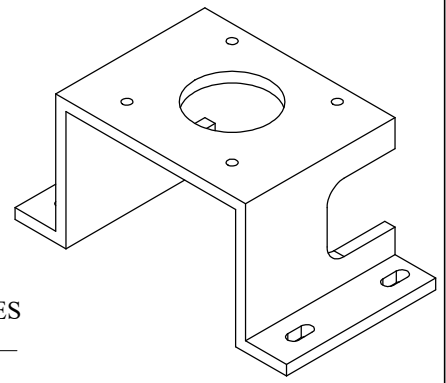
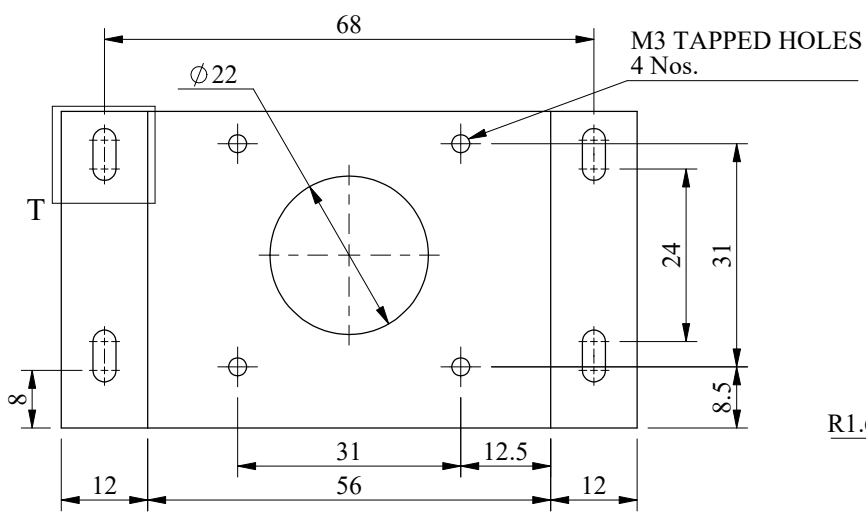

DETAIL T  
SCALE 2 : 1  
(TYP)

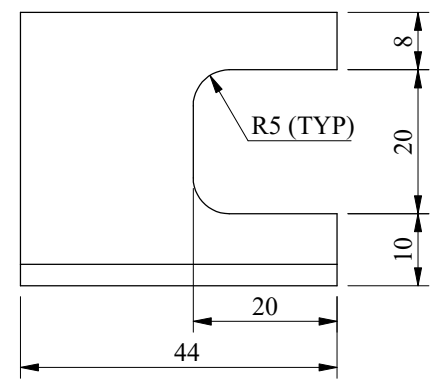
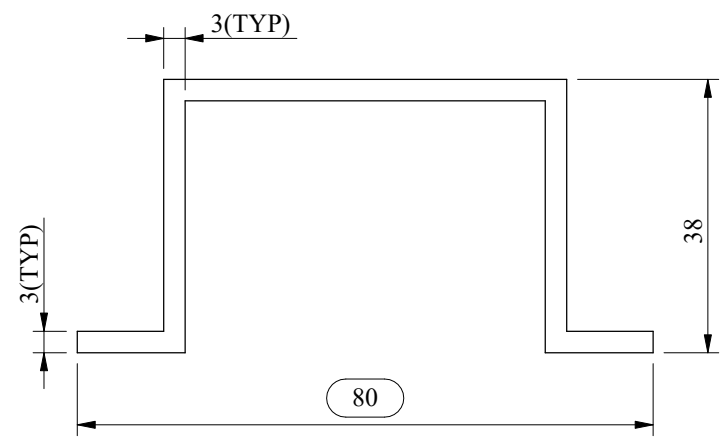

NOTES :-  
UNLESS OTHERWISE SPECIFIED  
1) ALL DIMENSIONS ARE IN mm.  
2) DO NOT SCALE THE DRAWING.  
3) SURFACE FINISH IN MICRON 3.2 CLA OR BETTER.  
4) ROUND ALL INTERNAL SHARP CORNERS BY 0.4R  
5) REMOVE ALL EXTERNAL SHARP CORNERS BY CHAMFER 0.5x45°  
6) GENERAL TOLERANCE AS PER IS:2102 (MEDIUM CLASS).

NO.	DESCRIPTION	DR'N DATE	APP'D
REVISIONS			
TITLE TIMING PULLEY BRACKET		APP'D	
PART NO.	11	SCALE 1:2	
MAT'L	AL 6061		
QTY/ASS'Y	1	FILE NAME -	

DR'N BY	AKSHAY	PROJECT : DSEA
DRG. CHKD.		
DSE'D BY		
DES.CHKD.		

DRG. NO.	
<b>A4-DSEA/DRHR/2021-22/311</b>	
REV. 0	DATE 28.12.2021

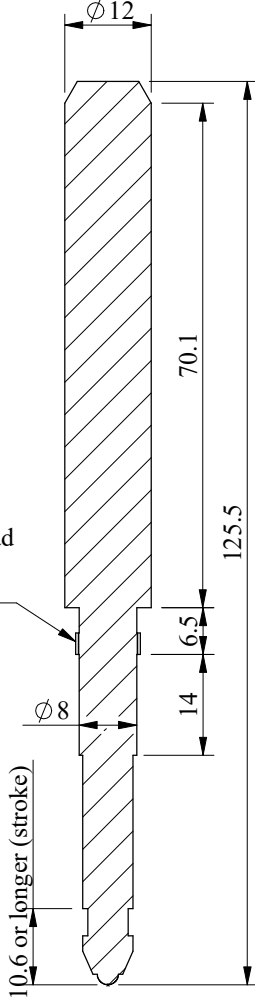
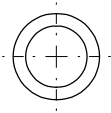

Attachment thread  
for thrust stem  
M9 X 0.5

SECTION A-A

MAKE	SOLARTRON
MODEL	ORBIT-DP/5/S

NOTES :-  
UNLESS OTHERWISE SPECIFIED  
1) ALL DIMENSIONS ARE IN mm.  
2) DO NOT SCALE THE DRAWING.  
3) SURFACE FINISH IN MICRON 3.2 CLA OR BETTER.  
4) ROUND ALL INTERNAL SHARP CORNERS BY 0.4R  
5) REMOVE ALL EXTERNAL SHARP CORNERS BY CHAMFER 0.5x45°  
6) GENERAL TOLERANCE AS PER IS:2102 (MEDIUM CLASS).

NO.	DESCRIPTION	DR'N DATE	APP'D
REVISIONS			
TITLE SLIM HEAD LINEAR GAUGE		APP'D	
PART NO.	12	SCALE 1:2	
MAT'L	STD		
QTY/ASS'Y	1	FILE NAME -	

DR'N BY	AKSHAY	PROJECT :DSEA
DRG. CHKD.		
DSE'D BY		
DES.CHKD.		

DRG. NO.	<b>A4-DSEA/DRHR/2021-22/312</b>
REV. 0	
DATE 28.12.2021	

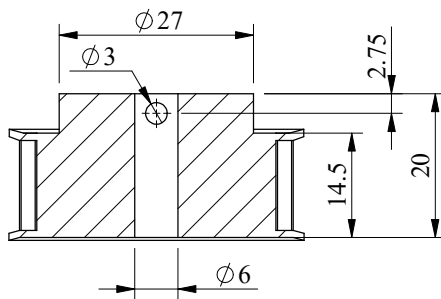
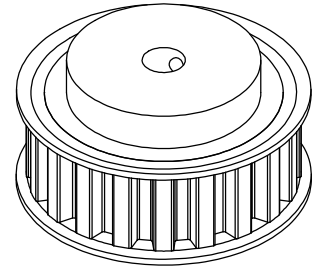
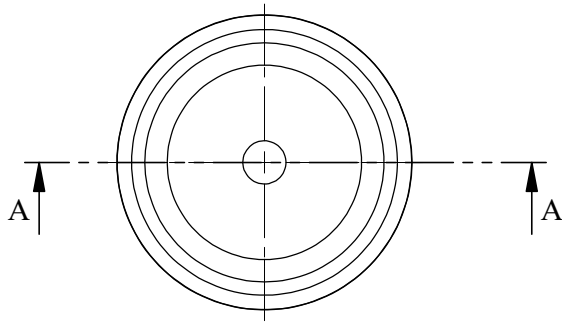

SECTION A-A

**PULLEY DATA**

PULLEY TYPE	HTD TIMING PULLEY
PROFILE	-
NO.OF TEETH	24
PITCH	5mm
P.C.D.	38.20
OD.	37.1 APROX
MAKE	CUSTOME MADE
MODEL NO.	
WEIGHT	-

NOTES :-

- UNLESS OTHERWISE SPECIFIED
- 1) ALL DIMENSIONS ARE IN mm.
- 2) DO NOT SCALE THE DRAWING.
- 3) SURFACE FINISH IN MICRON 3.2 CLA OR BETTER.
- 4) ROUND ALL INTERNAL SHARP CORNERS BY 0.4R
- 5) REMOVE ALL EXTERNAL SHARP CORNERS BY CHAMFER 0.5x45°
- 6) GENERAL TOLERANCE AS PER IS:2102 (MEDIUM CLASS).

NO.	DESCRIPTION	DR'N DATE	APP'D
REVISIONS			
TITLE <u>TIMING PUEELY 2</u>		APP'D	
PART NO.	13		SCALE 1:2
MAT'L	STD		
QTY/ASS'Y	1	FILE NAME -	

DR'N BY	AKSHAY	PROJECT : DSEA	DRG. NO.
DRG. CHKD.			<b>A4-DSEA/DRHR/2021-22/313</b>
DSE'D BY			REV. 0 DATE 29.12.2021
DES.CHKD.			

Ø3.51 THROUGH ALL

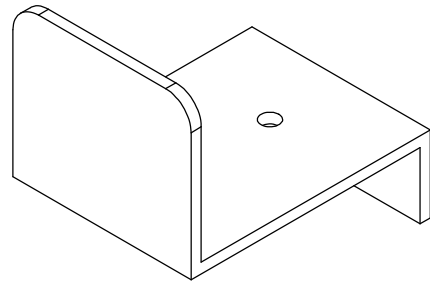
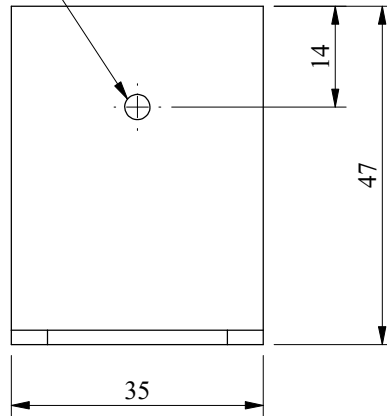

M3 TAPPED HOLES  
2 Nos. (AS SHOWN)

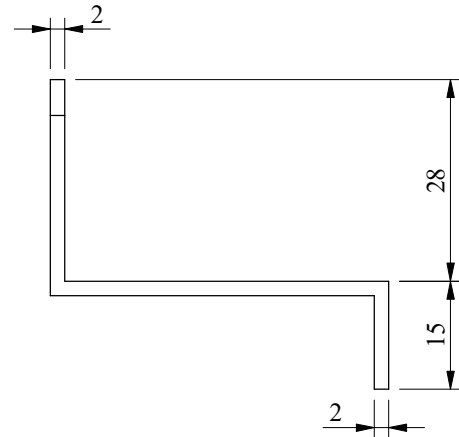
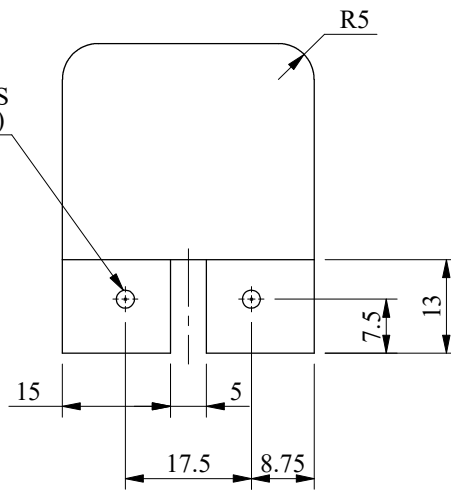

NOTES :-

UNLESS OTHERWISE SPECIFIED

- 1) ALL DIMENSIONS ARE IN mm.
- 2) DO NOT SCALE THE DRAWING.
- 3) SURFACE FINISH IN MICRON 3.2 CLA OR BETTER.
- 4) ROUND ALL INTERNAL SHARP CORNERS BY 0.4R
- 5) REMOVE ALL EXTERNAL SHARP CORNERS BY CHAMFER 0.5x45°
- 6) GENERAL TOLERANCE AS PER IS:2102 (MEDIUM CLASS).

NO.	DESCRIPTION	DR'N DATE	APP'D
REVISIONS			
TITLE <b>SUPPORT PLATE</b>		APP'D	
PART NO.	14	SCALE 1:2	
MAT'L	SS 304		
QTY/ASS'Y	1	FILE NAME	

DR'N BY	AKSHAY	PROJECT :DSEA
DRG. CHKD.		
DSE'D BY		
DES.CHKD.		

DRG. NO.	<b>A4-DSEADRHR/2021-22/314</b>
REV. 0	DATE 04.01.2021

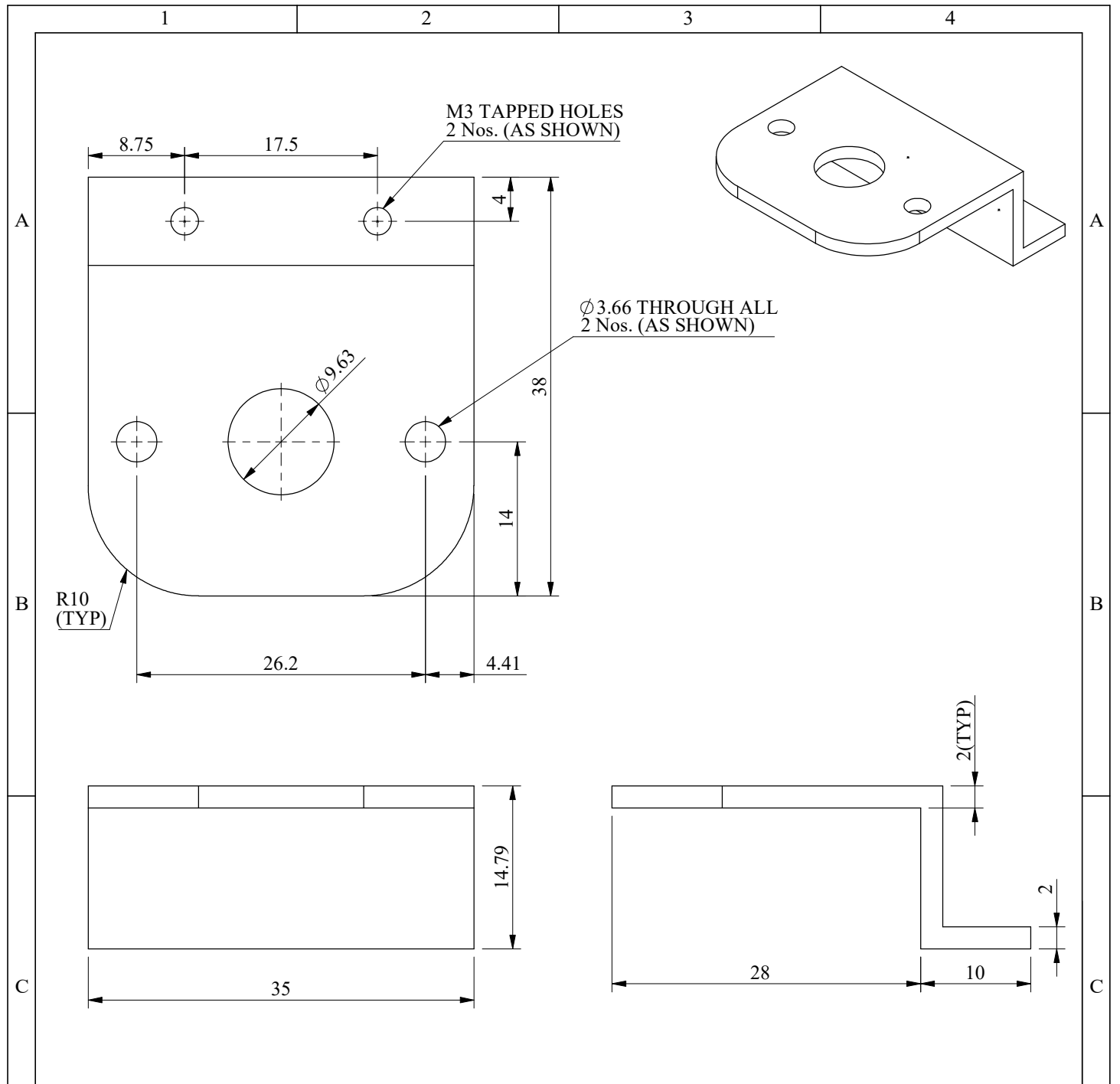

NOTES :-  
 UNLESS OTHERWISE SPECIFIED  
 1) ALL DIMENSIONS ARE IN mm.  
 2) DO NOT SCALE THE DRAWING.  
 3) SURFACE FINISH IN MICRON 3.2 CLA OR BETTER.  
 4) ROUND ALL INTERNAL SHARP CORNERS BY 0.4R  
 5) REMOVE ALL EXTERNAL SHARP CORNERS BY CHAMFER 0.5x45°  
 6) GENERAL TOLERANCE AS PER IS:2102 (MEDIUM CLASS).

NO.	DESCRIPTION	DR'N DATE	APP'D
REVISIONS			
TITLE <b>SUPPORT PLATE 2</b>		APP'D	
PART NO.	15		SCALE 1:2
MAT'L	AL 6061		
QTY/ASS'Y	1	FILE NAME	

DR'N BY	AKSHAY	PROJECT :DSEA
DRG. CHKD.		
DSE'D BY		
DES.CHKD.		

DRG. NO.	<b>A4-DSEA/DRHR/2021-22/315</b>
REV. 0	DATE 04.01.2021

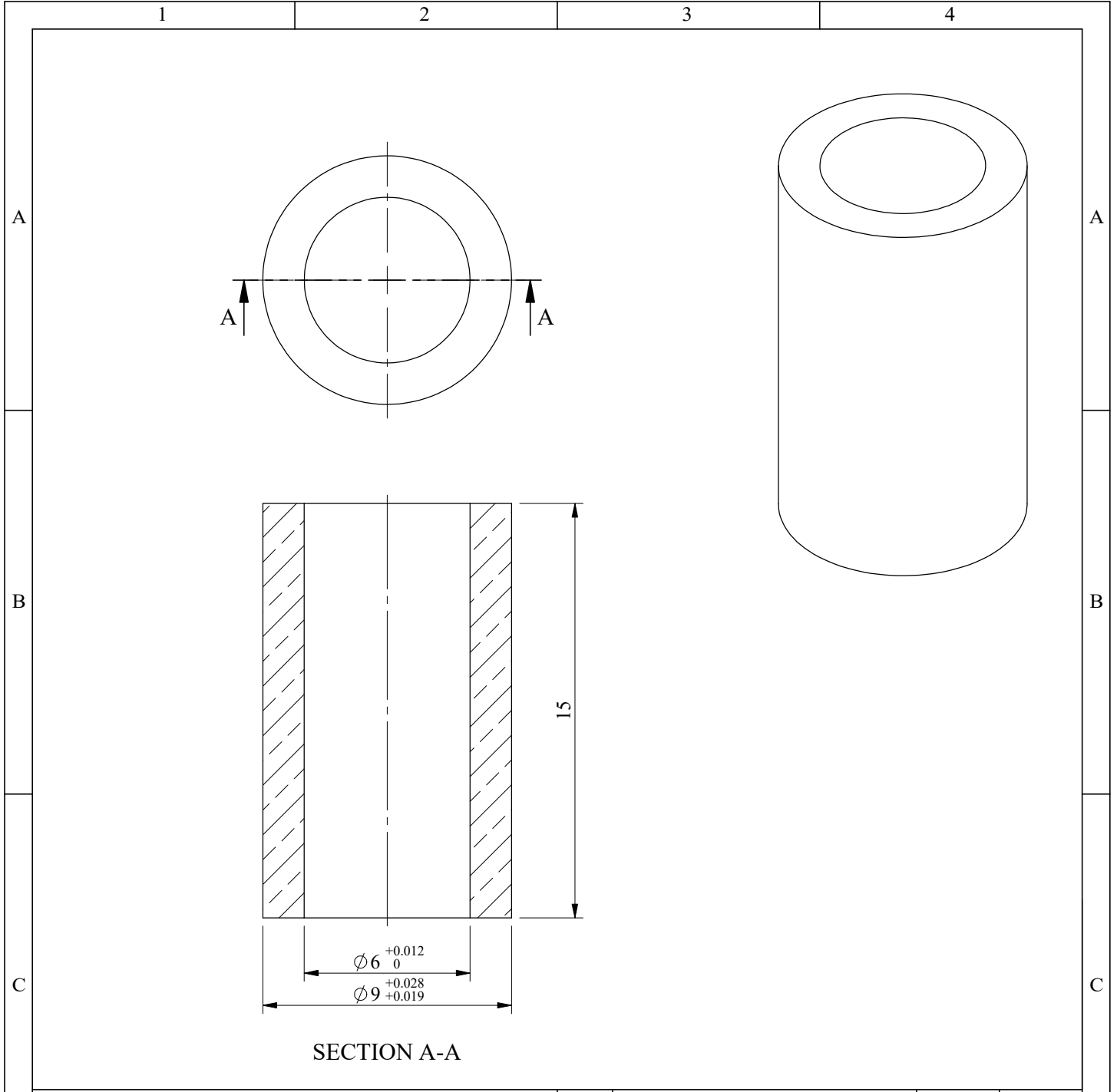

SECTION A-A

NOTES :-

UNLESS OTHERWISE SPECIFIED

- 1) ALL DIMENSIONS ARE IN mm.
- 2) DO NOT SCALE THE DRAWING.
- 3) SURFACE FINISH IN MICRON 3.2 CLA OR BETTER.
- 4) ROUND ALL INTERNAL SHARP CORNERS BY 0.4R
- 5) REMOVE ALL EXTERNAL SHARP CORNERS BY CHAMFER 0.5x45°
- 6) GENERAL TOLERANCE AS PER IS:2102 (MEDIUM CLASS).

NO.	DESCRIPTION	DR'N DATE	APP'D
REVISIONS			
TITLE		APP'D	
<b>BUSH</b>			
PART NO.	16	SCALE 1:2	
MAT'L	BRASS		
QTY/ASS'Y	2	FILE NAME -	
DR'N BY		DRG. NO.	
AKSHAY		<b>A4-DSEA/DRHR/2021-22/316</b>	
PROJECT : DSEA		REV. 0 DATE 05.01.2021	

DR'N BY	AKSHAY	PROJECT : DSEA
DRG. CHKD.		
DSE'D BY		
DES.CHKD.		





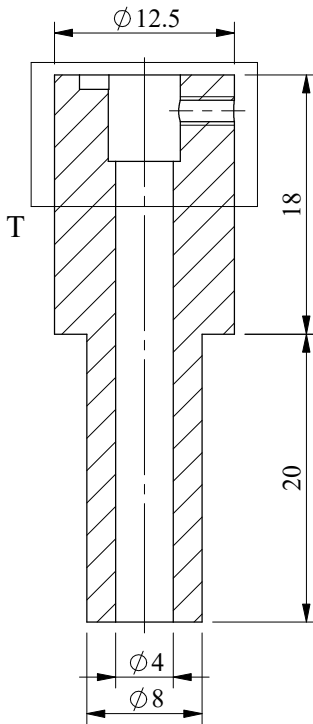
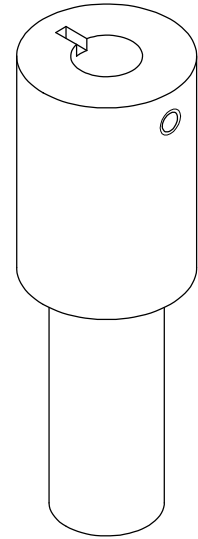
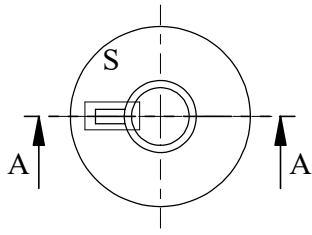

SECTION A-A

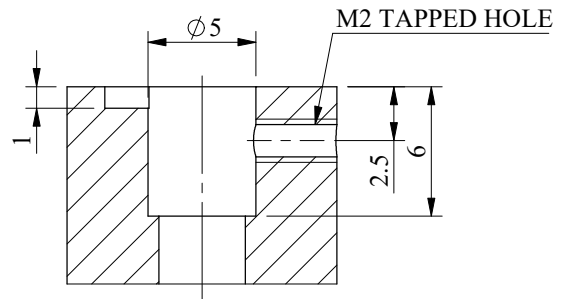

DETAIL T  
SCALE 3 : 1

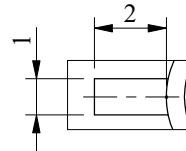

DETAIL S  
SCALE 5 : 1

NOTES :-

UNLESS OTHERWISE SPECIFIED

- 1) ALL DIMENSIONS ARE IN mm.
- 2) DO NOT SCALE THE DRAWING.
- 3) SURFACE FINISH IN MICRON 3.2 CLA OR BETTER.
- 4) ROUND ALL INTERNAL SHARP CORNERS BY 0.4R
- 5) REMOVE ALL EXTERNAL SHARP CORNERS BY CHAMFER 0.5x45°
- 6) GENERAL TOLERANCE AS PER IS:2102 (MEDIUM CLASS).

NO.	DESCRIPTION	DR'N DATE	APP'D
REVISIONS			
TITLE <b>ADAPTOR</b>		APP'D	
PART NO.	18		SCALE 1:2
MAT'L	AL 6061		
QTY/ASS'Y	1	FILE NAME -	

DR'N BY	AKSHAY	PROJECT : DSEA
DRG. CHKD.		
DSE'D BY		
DES.CHKD.		

DRG. NO.	<b>A4-DSEA/DRHR/2021-22/318</b>
REV. 0	DATE 06.01.2021

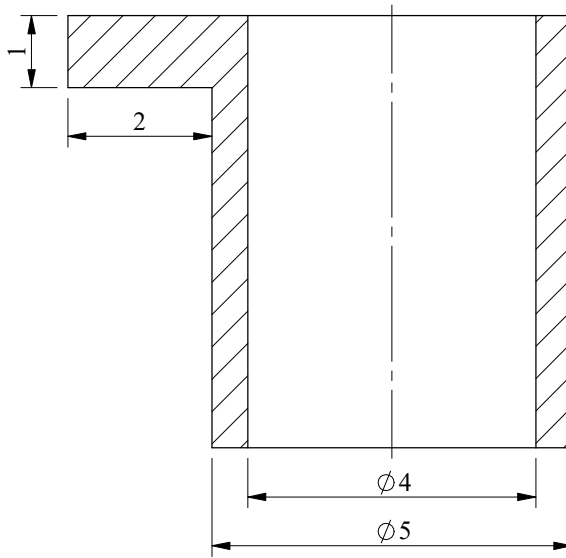
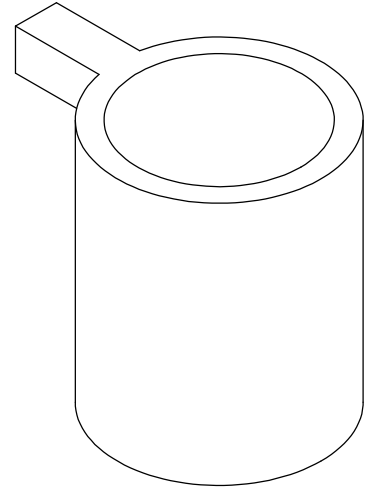
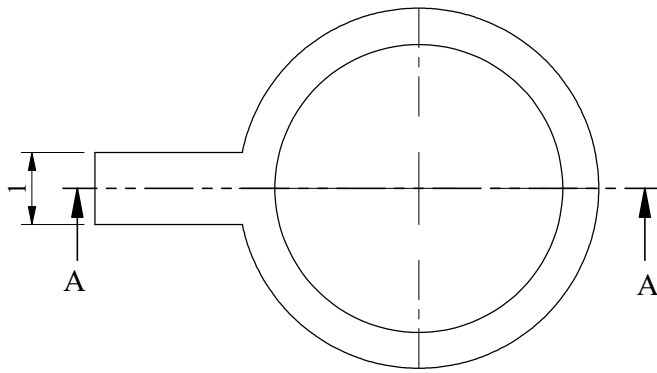

SECTION A-A  
SCALE 10 : 1

NOTES :-

UNLESS OTHERWISE SPECIFIED

- 1) ALL DIMENSIONS ARE IN mm.
- 2) DO NOT SCALE THE DRAWING.
- 3) SURFACE FINISH IN MICRON 3.2 CLA OR BETTER.
- 4) ROUND ALL INTERNAL SHARP CORNERS BY 0.4R
- 5) REMOVE ALL EXTERNAL SHARP CORNERS BY CHAMFER 0.5x45°
- 6) GENERAL TOLERANCE AS PER IS:2102 (MEDIUM CLASS).

NO.	DESCRIPTION	DR'N DATE	APP'D
REVISIONS			
TITLE		APP'D	
<u>SLEEVE</u>			
PART NO.	19	SCALE 1:2	
MAT'L	SS 304		
QTY/ASS'Y	1	FILE NAME	101
DR'N BY		DRG. NO.	
AKSHAY		A4-DSEA/DRHR/2021-22/319	
PROJECT : DSEA		REV. 0 DATE 06.01.2021	

DR'N BY	AKSHAY	PROJECT : DSEA
DRG. CHKD.		
DSE'D BY		
DES.CHKD.		

1

2

3

4

1 2 3 4 5 6 7 8

A

B

C

D

E

F

A

B

C

D

E

F

ITEM NO.	PART NAME	MATL.	QTY	DRAWING NO.	REMARKS
1	BASE PLATE	AL 6061	1	A4-DSEA-DRHR-2021-2022-351	
2	PLAQUE HOLDER	AL 6061	1	A4-DSEA-DRHR-2021-2022-352	
3	BEARING COVER	AL 6061	1	A4-DSEA-DRHR-2021-2022-353	
4	ROTARY HOLDER	AL 6061	1	A4-DSEA-DRHR-2021-2022-354	
5	PLAQUE	AL 6061	1	A4-DSEA-DRHR-2021-2022-355	
6	TIMING PULLEY 1	AL 6061	1	A4-DSEA-DRHR-2021-2022-356	

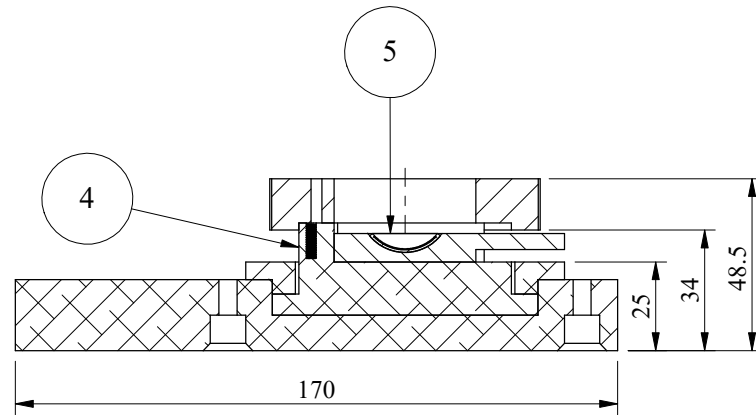
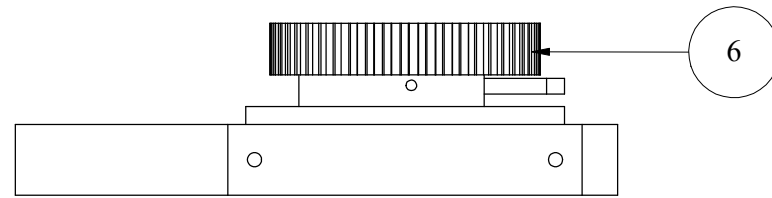
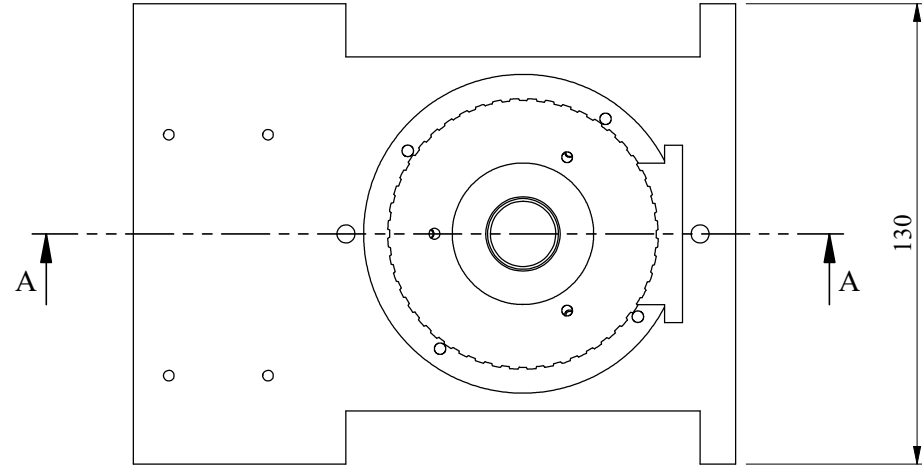

SECTION A-A

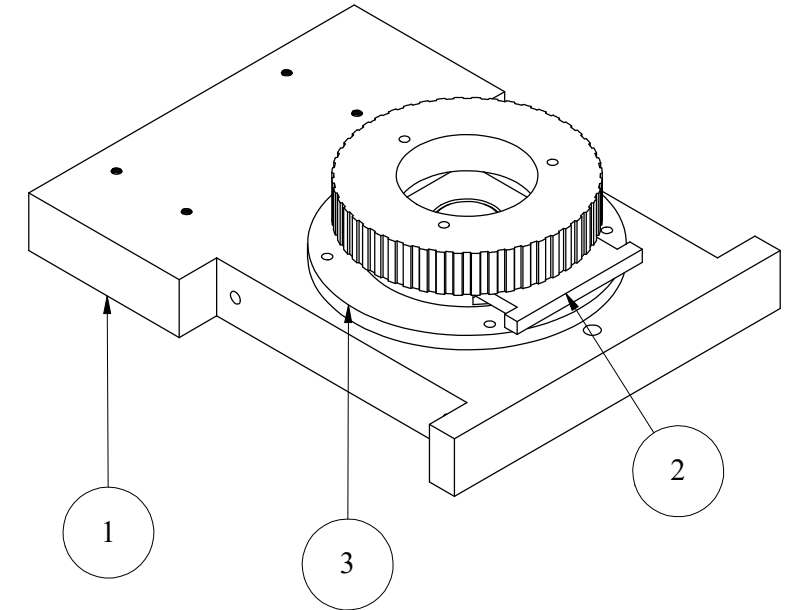

NOTES :-  
 UNLESS OTHERWISE SPECIFIED  
 1) ALL DIMENSIONS ARE IN mm.  
 2) DO NOT SCALE THE DRAWING.  
 3) SURFACE FINISH IN MICRON 3.2 CLA OR BETTER.  
 4) ROUND ALL INTERNAL SHARP CORNERS BY 0.4R  
 5) REMOVE ALL EXTERNAL SHARP CORNERS BY CHAMFER 0.5x45°  
 6) GENERAL TOLERANCE AS PER IS:2102 (MEDIUM CLASS).

PROJECT	DSEA	TITLE	BASE PLATE SUB-ASSY	
DRAWN BY	AKSHAY	DATE	27.12.2021	APPROVED
DRG. CHKD.		DATE		
DESIGNED BY		DES.CHKD.		PROJECTION
			FILE NAME	SCALE 1:1
			DRAWING NO. A3-DSEA/DRHR/2021-22/350	REV. 0

NO.	LOC.	DESCRIPTION	DRN. DATE	APPD. DATE
1	-	-	-	-
REVISIONS				

1 2 3 4 5 6 7 8

M3 TAPPED HOLES, 10 DEEP  
4Nos. (AS SHOWN)

M5 TAPPED HOLES  
10 DEEP, 2 Nos.

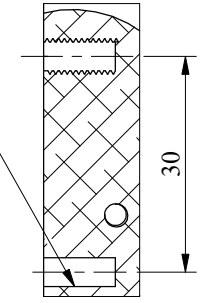
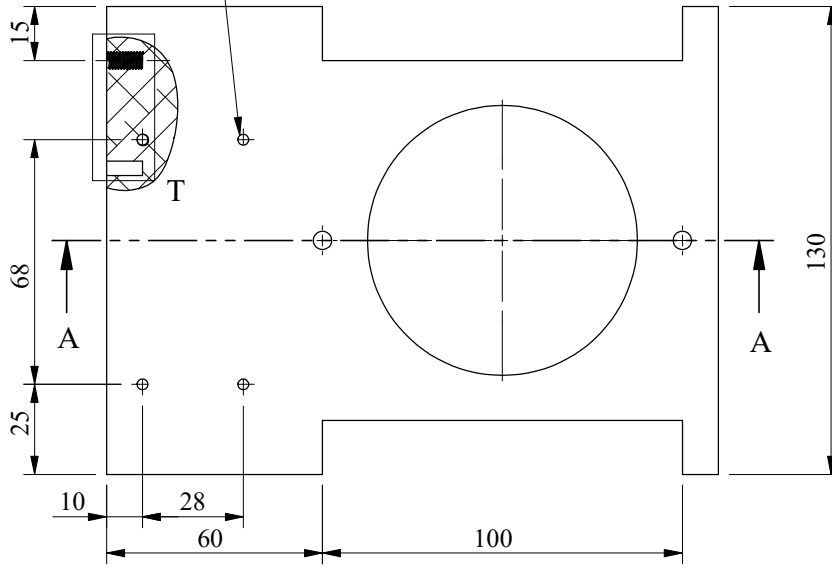

DETAIL T  
SCALE 1 : 1

M5 TAPPED HOLES, 10 DEEP  
4Nos. (AS SHOWN)

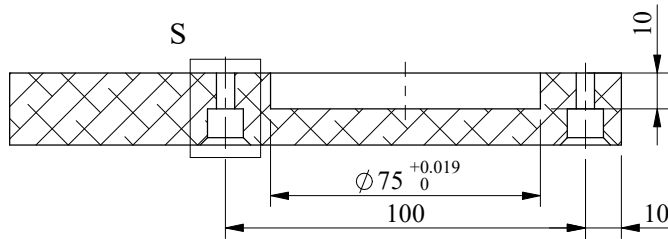
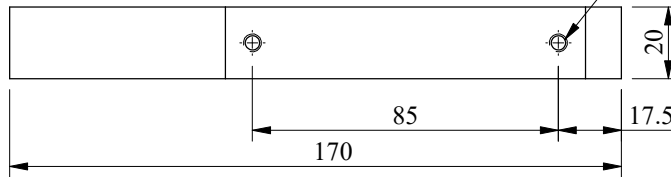

SECTION A-A

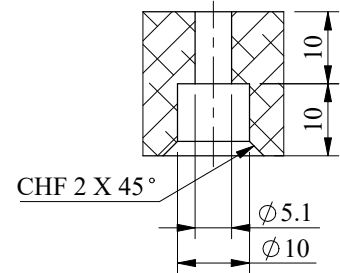

DETAIL S  
SCALE 1 : 1  
(TYP)

NOTES :-

- UNLESS OTHERWISE SPECIFIED
- 1) ALL DIMENSIONS ARE IN mm.
- 2) DO NOT SCALE THE DRAWING.
- 3) SURFACE FINISH IN MICRON 3.2 CLA OR BETTER.
- 4) ROUND ALL INTERNAL SHARP CORNERS BY 0.4R
- 5) REMOVE ALL EXTERNAL SHARP CORNERS BY CHAMFER 0.5x45°
- 6) GENERAL TOLERANCE AS PER IS:2102 (MEDIUM CLASS).

NO.	DESCRIPTION	DR'N DATE	APP'D
REVISIONS			
TITLE		APP'D	
BASE PLATE			
PART NO.	1	SCALE 1:2	
MAT'L	AL 6061		
QTY/ASS'Y	1	FILE NAME -	

DR'N BY	AKSHAY	PROJECT : DSEA
DRG. CHKD.		
DSE'D BY		
DES.CHKD.		

DRG. NO.	A4-DSEA/DRHR/2021-2022/351
REV. 0	DATE 27.12.2021



Ø3.2 THROUGH ALL  
EQUI. SPACED ON P.C.D. 80  
4Nos. (AS SHOWN)

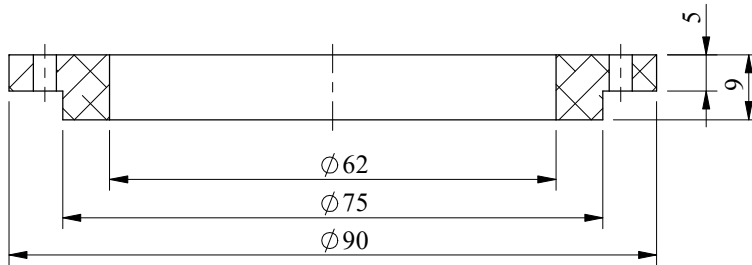
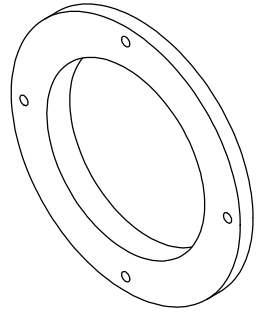
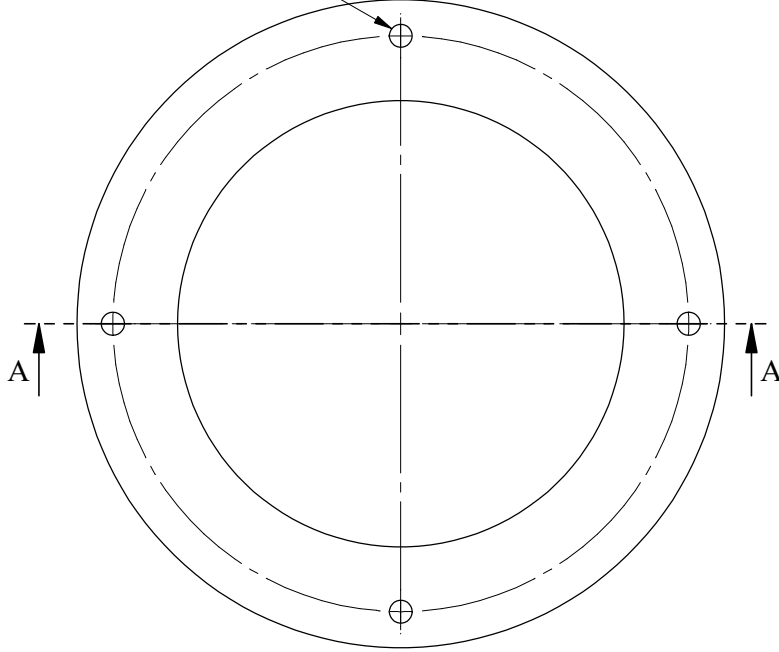

SECTION A-A

NOTES :-

UNLESS OTHERWISE SPECIFIED

- 1) ALL DIMENSIONS ARE IN mm.
- 2) DO NOT SCALE THE DRAWING.
- 3) SURFACE FINISH IN MICRON 3.2 CLA OR BETTER.
- 4) ROUND ALL INTERNAL SHARP CORNERS BY 0.4R
- 5) REMOVE ALL EXTERNAL SHARP CORNERS BY CHAMFER 0.5x45°
- 6) GENERAL TOLERANCE AS PER IS:2102 (MEDIUM CLASS).

NO.	DESCRIPTION	DR'N DATE	APP'D
REVISIONS			
TITLE <b>BEARING COVER</b>		APP'D	
PART NO.	3		SCALE 1:2
MAT'L	AL 6061		
QTY/ASS'Y	1	FILE NAME -	

DR'N BY	AKSHAY	PROJECT : DSEA	DRG. NO.
DRG. CHKD.			<b>A4-DSEA/DRHR/2021-2022/353</b>
DSE'D BY			REV. 0 DATE 27.12.2021
DES.CHKD.			

1

2

3

4





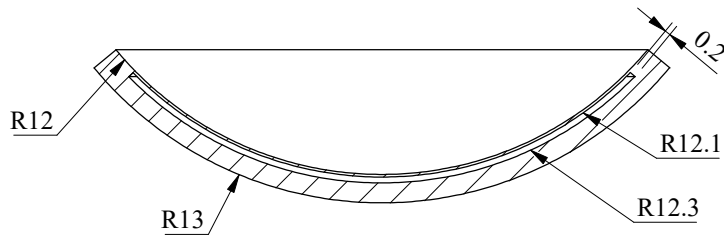
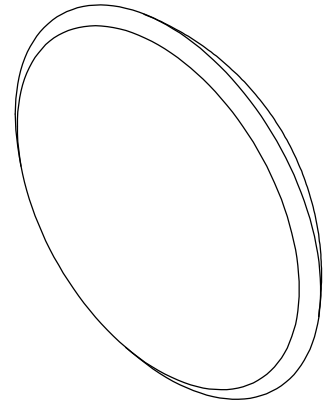
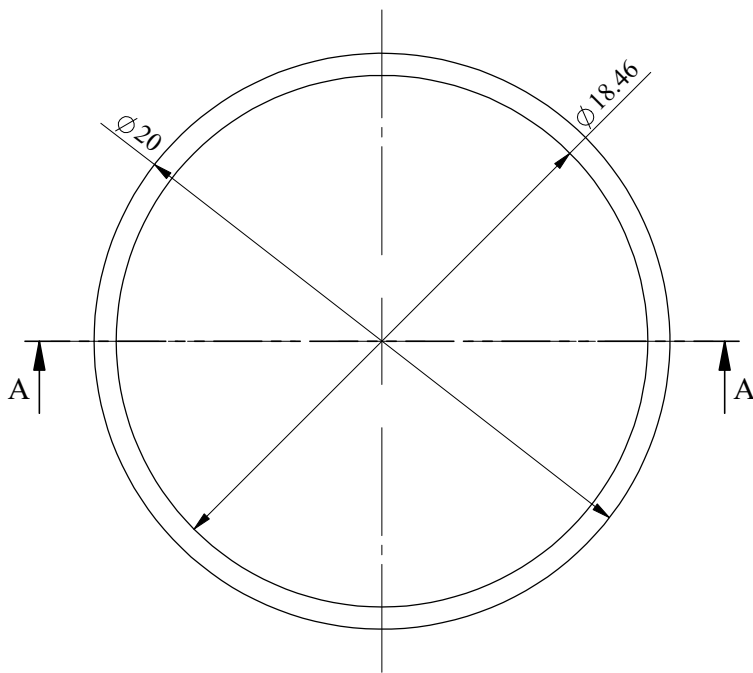

SECTION A-A  
SCALE 4 : 1

NOT IN THE SCOPE OF SUPPLY

NOTES :-

UNLESS OTHERWISE SPECIFIED

- 1) ALL DIMENSIONS ARE IN mm.
- 2) DO NOT SCALE THE DRAWING.
- 3) SURFACE FINISH IN MICRON 3.2 CLA OR BETTER.
- 4) ROUND ALL INTERNAL SHARP CORNERS BY 0.4R
- 5) REMOVE ALL EXTERNAL SHARP CORNERS BY CHAMFER 0.5x45°
- 6) GENERAL TOLERANCE AS PER IS:2102 (MEDIUM CLASS).

NO.	DESCRIPTION	DR'N DATE	APP'D
REVISIONS			
TITLE <b>DUMMY PLAQUE</b>		APP'D	
PART NO.	5	SCALE 1:2	
MAT'L	AL 6061		
QTY/ASS'Y	1	FILE NAME -	

DR'N BY	AKSHAY	PROJECT :DSEA	DRG. NO.
DRG. CHKD.			<b>A4-DSEA/DRHR/2021-22/355</b>
DSE'D BY			REV. 0 DATE 27.12.2021
DES.CHKD.			

1

2

3

4

