

Government of India
Bhabha Atomic Research Centre
Security Electronics & Software Systems Division

Ref: BARC/SESSD/AKB/2022+1/P 46898

Date: 31/5/2022

Sub: Invitation of Quotation for Design & Fabrication of Vibration Isolation Table with instrument rack & computer table for SEM

Dear Sirs,

1. Quotations are invited for the minor fabrication job, as per the enclosed specifications in **annexures I**.
2. Bidder shall quote for the entire work involved in this fabrication.
3. Taxes/GST/IGST/other charges shall be quoted separately.
4. **Technical & Commercial parts of the offer have to be furnish separately in the offer.**
5. The quotation must reach Head, Security Electronics & Software Systems Division by 15/06/2022 and must be sent in a sealed envelope super scribed with the reference number & the due date given above. The quotations must be sent through **Indian Postal Service only** and hand delivery or courier delivery of quotations will not be accepted. **The sealed quotation shall contain Technical & Commercial parts of the offer in two separate sealed envelopes, differentiated clearly by the terms "TECHNICAL" & "COMMERCIAL" super-scribed on the respective envelops**
6. The address on the envelope should read:
**Head, Security Electronics & Software Systems Division
BARC, Trombay,
Mumbai – 400085.
(Kind Attn: Shri N. K Yadav, SO/F)**
7. For any clarification regarding fabrication work, please contact by e-mail at nkyadav@barc.gov.in and phone on 022-25594894.
8. The fabrication work shall be subjected to inspection by our engineers. The finished components shall not be dispatched prior to approval by our engineer. Facility for necessary inspection should be provided to the engineer deputed for inspection of the job during fabrication at bidder's premises.
9. The bidder shall deliver the finished components after approval by our engineer/officer within **3 months** from the date of issue of work order to the bidder. The finished components along with left over materials shall be delivered at **SESSD, BARC, Trombay, Mumbai - 400 085**.
10. Head, Security Electronics & Software Services Division reserves the rights to accept / reject any or all quotations without assigning any reason.
11. Delivery charges, if any, must be clearly mentioned in the offer.
12. Quotation must also indicate the applicable GST separately for items and duration of validity of offer.
13. The Bidder should also provide GSTIN/PAN/TAN/GIR No.
14. Income tax@2% and GST TDS 2% will be deducted from your bill.
15. Any delay which is attributed to the contractor is liable for imposition of penalty@ 0.5% per week (max 10%) on the contractor.
16. Supplier is required to comply with ITR requirements stipulated as per Section 206AB of Income Tax Act, 1961.

Encl.: Annexure- I

ए के यादव / Shri N. K. Yadav, SO/F
अध्यक्ष / Head
सुरक्षा, इलेक्ट्रॉनिक्स एवं सॉफ्टवेयर प्रणाली प्रभाग
Security Electronics & Software Systems Division
श्रीमान परमाणु अनुसंधान केंद्र
Bhabha Atomic Research Centre
भारत सरकार / Government of India
ट्रॉम्बे, मुम्बई / Trombay, Mumbai - 400085.

भारत सरकार
भाभा परमाणु अनुसंधान केंद्र
सुरक्षा इलेक्ट्रॉनिक्स एवं क्रमानुदेश प्रणाली प्रभाग

संदर्भ: BARC/SESSD/AKB/2022/

दिनांक:

विषय: " वाइब्रेशन आइसोलेशन टेबल के साथ इन्स्ट्रुमेंट रैक और कम्प्यूटर टेबल का फ़ैब्रीकेशन " हेतु निविदा का आमंत्रण

1. अनुबंध के अनुसार, लघु निर्माण कार्य के लिए निविदा आमंत्रित किये जाते हैं ।
2. प्रदायकों को अनुबंध के अनुसार लघु निर्माण कार्य के लिए निविदा जमा करना होगा । यह कार्य सामग्री की आपूर्ति के बिना कार्यान्वित किया जायेगा ।
3. निविदा में करों और उत्पाद शुल्क को अलग से दर्शाया जाये।
4. निविदा अध्यक्ष, एस. इ. एस. एस. डी को दिनांक 15/06/2022, १८३० घ. तक पहुंच जाना चाहिए तथा मोहरबंद लिफाफे पर सन्दर्भ संख्या एवं ऊपर लिखित निर्धारित तिथि लिखी होनी चाहिए ।
5. लिफाफे पर पते को इस प्रकार लिखा जाना चाहिए :
**अध्यक्ष, सुरक्षा इलेक्ट्रॉनिक्स एवं क्रमानुदेश प्रणाली प्रभाग,
भा.प.अ.केंद्र, ट्रॉम्बे, मुंबई - ४०००८५
[ध्यानकर्षण: श्री न. कु. यादव, वैज्ञानिक अधिकारी (एफ)]**
6. कार्य हमारे अधिकारी की देखरेख में किया जाएगा ।
7. हमारे अधिकारी की देखरेख में प्रदायक को कार्यदिश मिलने कि तिथि से 3 महीने के अंदर कार्य पूरा करना पड़ेगा।
8. निम्नहस्ताक्षरता बिना कोई कारण दर्शाये किसी भी या सभी निविदा को स्वीकार व अस्वीकार करने का अधिकार सुरक्षित रखते हैं ।
9. निविदा में प्रस्ताव की वैधता भी दर्शाई जानी चाहिए ।
10. निविदा केवल मुद्रित लेटर हेड प्रारूप में ही दिए जाएं। कम्प्यूटर जनित फार्म में प्राप्त निविदा को अवैध मानते हुए खारिज कर दिया जायेगा।
11. निविदा में प्रदायकों का पैन, वैट तथा सर्विस टैक्स रजिस्ट्रेशन नंबर शामिल रहना चाहिए।
12. प्रदायकों को माल एवं सेवा कर (जी.एस.टी) के अंतर्गत पंजीकृत होना चाहिए एवं कार्य के विषय में विस्तृत आदेश के अनुसार यथा लागू जी.एस.टी का भूगतान सम्बंधित कर प्राधिकारियों को प्रदायक द्वारा किया जायेगा ।
13. निविदा से प्राप्त की गयी दरों में जीएसटी / अन्य कर शामिल होंगे और इनका भुगतान प्रदायक द्वारा किया जायेगा तथा इस सम्बन्ध में किये गए किसी भी दावे पर भापअ केंद्र द्वारा विचार नहीं किया जायेगा । तथापि, प्रदायक द्वारा उपलब्ध कराई गयी सेवा (सीजीएसटी अधिनियम, २०१७ में यथा उपलब्ध) की आपूर्ति के समय जीएसटी के घटकों को सत्यापित किया जायेगा, यदि विस्तार सहित निविदा की प्राप्ति की अंतिम तारीख पर लागू घटकों में कोई परिवर्तन हुआ तो ।

अ. कू. भट्टाचार्य
(डॉ. अ. कू. भट्टाचार्य)
उत्कृष्ट वैज्ञानिक तथा अध्यक्ष,
एस. इ. एस. एस. डी

संलग्न: अनुबंध - I

ए के भट्टाचार्य / A. K. Bhattacharjee

अध्यक्ष / Head
सुरक्षा इलेक्ट्रॉनिक्स एवं सॉफ्टवेयर प्रणाली प्रभाग
Security Electronics & Software Systems Division
भाभा परमाणु अनुसंधान केंद्र
Bhabha Atomic Research Centre
भारत सरकार / Government of India
ट्रॉम्बे, मुम्बई / Trombay, Mumbai - 400085.

Annexure-I

Specifications for Design & Fabrication of vibration isolation table with instrument rack & computer table for SEM

A. Brief Description

The SEM is vibration sensitive instrument & requires vibration free table. For isolating the vacuum chamber of SEM from vibrations, the chamber has to be mounted on spring based vibration isolation table. This spring based vibration isolation table is to be designed & fabricated along with customized instrument rack & computer table. A diagram showing vibration isolation table is given in Annexure- II & III. The assembly drawing of vibration isolation table ,customized instrument rack & computer table is attached. The detailed specifications for fabrication of above items are described below: -

B. Scope of work:

Vendor would quote for two complete set of vibration isolation table along with rack & computer Table . Part quotation will not be accepted. The fabrication work would include the followings.

1. Fabrication of Vibration isolation table for SEM.
2. Fabrication of Customized Instrument rack.
3. Fabrication of dedicated computer table.
4. Fabricated products should have better surface finish with powder coating for aesthetic look.
5. Vibration isolation table should give minimum 20 dB attenuation for any frequency.
6. Acceptance will be based on testing result of the isolation table with required system natural frequency of <2 Hz.
7. Preparation & submission of detailed manufacturing drawing of all the three items before commencement of job.
8. After satisfactory inspection of first set of isolation table, instrument rack & computer table, vendor will start fabrication of 2nd set of isolation table, instrument rack & computer table.
9. It is in scope of vendor to provide all the test facility & show the result of measurement of attenuation & natural frequency as stated above.

C. Quantity Required: 2 Sets.

One Set includes following components:

1 Set: 1 no. Vibration Isolation table + 2 nos. Customized Racks + 2 nos. Computer Tables

i.e. total components are:

- i. Vibration Isolation table: **2 nos.**
- ii. Customized Instrument Rack: **4 nos.**
- iii. Computer Table: **4 nos.**

D. Specification of vibration isolation table for SEM: -

1. Overall dimension of vibration isolation table will be 770mm (L) x770mm (W) x800mm (H).
2. Load bearing capacity of vibration isolation table should be approx. 120 Kg.
3. The main components of the table are- Top glass cover & corrugated rubber sheet, top plate, top side cover, table frame assembly, springs, spring frame assembly, leaf spring assembly, bottom plate, table door & side covers. The assembly drawing of table is shown as B-100. The detail description of each component is given below: -

3.1 Top plate specification:

- 3.1.1 Overall size: 770mm (L) x770mm (W) x3 mm (T) with a central hole of dia. 305 mm. The top plate should be made in two separate parts as per the drawing attached as E-101 & E-101(2).
- 3.1.2 The top plate must be bended by 10 mm from all the side maintaining overall dimension.

3.1.3 Top plate material: Magnetic SS 410.

3.1.4 Top glass cover & corrugated rubber sheet will be same as the top plate. Thickness of glass will be 8mm & rubber will be 3mm.

3.2 Top side cover specification:

3.2.1 Cover plate is to be provided under top plate which will be mounted on base plate from all the four direction. The dimension of cover plate for one side will be 750mm (L)x108mm(H)x 2mm (T). Refer drawing as D-103.

3.2.2 Material: MS.

3.3 Specification of Table Frame assembly:

3.3.1 Table frame should be made of MS square tubes (50mm x 50mm x 3mm(T) with length of 650mm as shown in drag. D-120.

3.3.2 Table frame will hold the spring frame assembly kept on the base plate.

3.3.3 A base plate of MS with dimension 770 mm(L) x 770 mm (W) x 10 mm (T) will rest on Table frame & will be welded with table frame. Refer drag. D-106.

3.3.4 A M.S. sheet (bottom plate) of 3 mm thick with appropriate length & width is to be mounted inside at bottom of the table frame with knob screw as shown in drawing E-109.

3.4 Specification of the Springs:

3.4.1 Four nos. of helical springs should be mounted on spring base plate at specified locations (4 corners) as shown in drawing D-150. Each spring should be design & fabricated with following design parameters: -

A) Spring length: 122 mm

B) OD: 87.3 mm

C) Isolation efficiency(attenuation): >20 dB

3.4.2 The testing of spring based isolation table will be done at vendor site. The required natural frequency of the isolation system using above spring should be < 2 Hz .

3.4.3 Three more sets of springs (one set consists of 4 nos. spring) of different spring constant are to be fabricated & supplied by the vendor as a spare. The spring constant of each spare set will be finalized by mutual agreed data as per the system requirement.

3.4.4 Vendor has to demonstrate the testing of spare sets of spring for given spring constant.

3.4.5 Four nos. of rubber bellows containing valve has be fitted inside of springs.

3.5 Specification of the Spring Frame Assembly: Refer : Refer drawing E-151.

3.5.1 A M.S. square frame of 600x600 mm is to be fabricated from the rectangular tube size 600x40x20 mm x 2.5 mm (T) as shown in attached drawing as E-151.

3.5.2 At the center of the spring frame assembly a M.S. chamber base plate of 325x325x10 mm is to be welded on spring frame assembly. A hole of \varnothing 170 mm is to be made in the center of M.S. chamber base plate. Refer drag. E-152

3.5.3 Silicon rubber sheet of 300x300x5 mm will be kept above chamber base plate. Extra 1000x1000x5 mm & 3mm Si rubber sheet should be supplied by vendor.

3.5.4 Spring should be mounted on the base plate as per the drawing.

3.6 Leaf spring assembly: refer drawing E-200

3.6.1 Frictional roller arrangement must be provided for vibration isolation as per the drawing. For this purpose a leaf spring of stiffness 1 N/meter is to be designed. Two addition set of same leaf spring should be supplied by the vendor.

4. The height of table must be adjustable within the range of \pm 10mm resting on this support legs.

5. There is no moving load. The total load will be concentrated at middle of isolated frame.

6. Vibration isolation table should give minimum 20 dB attenuation for any frequency.

7. The detail manufacturing drawing should be prepared & submitted to the user by vendor before starting the Fabrication work.

8. The Table should be mounted on heavy duty adjusting leveling caster wheels. For easy transport of equipment, it should have swivel & locking feature.
9. There should be no sharp edges on any fabricated parts/components. All edges will be rounded. The table will be covered by the MS sheet of thickness 2 mm from all the direction. The sides & back cover will be fixed by screws for opening & closing as shown in drawing E-107 & E107(2). Front door will be opened from middle part & hinged at both the corner as shown in drawing E-108 & it should have magnetic door locking system. Two hole of dia. 40 mm & 20 mm is to be provided at the center of back cover of table as per the attached drawing as E-107(2).
10. All the cover plates will be Powder Coated for corrosion resistance & better appearance. The Vendor should provide color options to the indenter for recommendation.
11. Pre-dispatch inspection will be carried out at vendor site before delivery & final product will be accepted if it meets all user's acceptance criteria.
12. Final product should be powder coated.
13. The deliverables should have warranty for a period of one year from the date of final receipt at purchaser's premises.
14. Vendor should be agreeable to accept minor changes in the drawing/design if felt necessary by the user.
15. Vendor have to provide corrugated rubber of 3mm thickness & glass of 8mm thickness (as per the top plate dimension) for keeping at top cover for better appearance. The drawing E-101, E-101(2) & E101(3)(4) for the same is attached .

Specification of computer table for SEM:

A computer table is to be fabricated for keeping monitors & other instrument of SEM.

Detail specification is given below: -

1. The overall dimension of computer table will be 900 mm (L) x 750 mm (W) x 800 mm (H). The top of table will be made of pre-laminated particle board of thickness not less than 20mm & size will be 750 mm x 900 mm. Please refer the drawing for more detail.
2. Table frame should be made of MS square tubes (30mm x 30mm x 3mm(T) as shown in drag.
3. The left, right & back side of table will be covered by perforated MS sheet with thickness of 3mm. All the three side will be welded with leg of table.
 1. The top cover of the table will be tightly fitted with the frame & also screwed from four side. The sides of top cover should have wooden beeding for smoothness.
5. The Table should be mounted on heavy duty adjusting leveling caster wheels. For easy transport of equipment, it should have swivel & locking feature.
6. The height of table must be adjustable within the range of ± 10 mm resting on this support legs.
7. There should be no sharp edges on any fabricated parts/components. All edges will be rounded.
8. All the cover plates will be painted for corrosion resistance & better appearance. The Vendor should provide color options to the indenter for painting recommendation.
9. Pre-dispatch inspection will be carried out at vendor site before delivery & final product will be accepted if it meets all user's acceptance criteria.
10. Final product should be powder coated.
- 11.. Vendor have to provide corrugated rubber of thickness 3mm & glass of thickness 8mm for keeping at the top cover for better appearance.
12. Vendor should be agreeable to accept minor changes in the drawing/design if felt necessary by the user.
13. There will be provision of sliding tray under the top cover for keeping key board & mouse.

E. Customized instrument rack:

Gist:

The customized electronics rack is intended to accommodate several sub-systems of SI. The rack should have provision for cable guides inside the rack and from the rack to other systems. There should be provision to adjust the height upto ± 10 mm. The rack should have hinged door at the front, removable side and back plates and supported by castor wheels & adjustable

mounting pads. The castor wheels are used only during moving the rack indoors. While stationary, the rack should be supported only by adjustable mounting pads. The back and side of the rack should have thru. holes to allow the wires going inside/outside the rack.

Specifications of customized rack:-

1. The rack should accommodate several equipment/units in different shelves. Total 3 no. of shelves should be provided within the rack. The height of the shelves should be **adjustable** along the overall height of the rack with a distance of 1.75 inches or lower between any two adjacent holes.
2. The arrangement of the systems is given below and is represented in Figure 1. There will be 3 nos. of total shelf. Load bearing capacity of each shelf should be 25kg.
3. Each shelf in the rack should withstand a maximum weight of **50% higher** than the weights mentioned above without any visible deformation and sagging in it.
4. The rack top should be of pre-laminated particle board of thickness not less than 20mm. Body of the rack should be made of mild steel sheets of suitable gauge and should be powdered coated with **smooth matte finish**. Details of colour shades shall be finalized during fabrication.
5. All mild steel parts should have epoxy powder coating of thickness not less than 50 microns for corrosion resistance. Due process of powder coating involving steps like pre-cleaning, degreasing, phosphating, passivation etc. should be followed during manufacturing.
6. Provision should be there for ease of removal and assembling of the **back panel** of the rack.
7. The back panel of the rack should have a cut out for entry of cables and proper arrangement should be provided with cable hole cover to cover remaining empty space after inserting the cables.
8. Provision should be provided for cable guides inside the rack.
9. Provision of **mains power supply** for sub-systems should be there inside the rack. **3 nos.** of surge protectors each with **6 sockets** and minimum **cable length of 3 meters**.
10. Provision of metallic double **hinged door** along with magnetic lock at the front with a door opening angle of 110 degrees or more should be provided.
11. The rack should be supported with caster wheels. Good quality PU or molded Nylon castor wheels fitted should be used.
12. Wheels should have twin wheel castor swivel mechanism.
13. The castor wheels are used only during moving the rack indoors. While stationary, the rack should be supported only by adjustable mounting pads with PU/molded nylon pads at the bottom of the rack.
14. Provision should be there for height adjustment of ± 10 mm through adjustable mounting pads.
15. Provision should be made available in the rack for convective cooling of electronics enclosed. Minimum of **4 fans** to be mounted with silicon pad on suitable locations of the rack. The airflow of the rack should be 90CFM or more and also the fans should be noiseless. Exact location of the fans would be decided before initiation of fabrication.
16. Venting holes or slits should be provided on side-panel of the rack. Details of the vent holes/slits shall be finalized before initiation of fabrication.
17. Provision should be there for earthing the rack.
18. Three Si rubber sheets of thickness 3mm with the dimension of each self should be provided which will be mounted on each self.
19. Vendor have to provide corrugated rubber & glass for keeping at the top cover for better Appearance.

F. Pre-dispatch Inspection: -

In the event of placement of work-order, on-site inspection will be performed by the users during material procurement, manufacturing, assembly stages or at any intermediate stage,

with prior notice to the supplier. The final product will be inspected by the users before delivery at supplier's premises.

G. Acceptance criteria: -

1. The final product will be accepted only after detailed inspection of the items.
2. All the fabricated parts will be verified in detail at the vendor's site by measuring the dimensions, surface finish, tolerances etc.
3. It is the vendor's responsibility to show the dimensional compliance of the fabricated parts with their corresponding drawing requirements to the indenter. Hence, vendor should have arranged all the necessary tools for measurement of dimension, surface finish, roundness, angle, tolerances etc. which are deemed necessary to comply with the drawing requirements.
4. Testing of spring constant of each spring should be carried out as per design requirement. Performance testing of vibration isolation table should be carried out by vendor & all results should be satisfactory.
5. Vibration isolation table should give minimum 20 dB attenuation for any frequency. All the necessary arrangement will be done by vendor to show the attenuation efficiency to indenter.
6. Acceptance will be based on testing result of the isolation table with required system natural frequency of <2 Hz. It is vendor responsibility to test & show the result.
7. After the final acceptance of the products by the indenter, the supplier may deliver the product to the user's site.

H. Deliverables: -

- i. **Two set.** This include 2nos. of Vibration isolation table, 4 nos. of instrument rack & 4 nos. of computer table for SEM.
- ii. Final complete manufacturing drawings of the above system.
- iii. Testing report of the each of the above.

I. Delivery schedule

Estimated delivery period is 03 months from the date of order placement.

J. Technical evaluation of offer and supplier:-

Technical Compliance Proforma is enclosed as Annexure-IV for technical evaluation of offer and prospective vendor competence. **All offers must accompany duly filled Technical Compliance Proforma bearing signature and stamp of authorized signatory of the company, failing which the offer shall be considered technically unsuitable and rejected outright without.**

K. General.

1. Offers received after due date or without bearing reference no. on the envelope are likely to be rejected .
2. Your offer shall indicate the total cost including the taxes.
3. **Taxes:** All applicable taxes should be clearly mentioned separately.
4. **Inspection / Guarantee:** All the individual items shall be inspected before dispatch. The items supplied shall be guaranteed for free repair/replacement for a period of one year from date of acceptance.
5. The goods proposed to be fabricated based on this NIT is meant for Research Institution under the Department of Atomic Energy & therefore the price to be quoted for the product should be exclusive of the excise duty. The purchaser will make available to the successful bidder

with whom a work order is placed, the excise duty exemption certificate duly signed by authorized officer of DAE well before the dispatch of goods by supplier. While submitting the offer, the bidder should specify in his offer that the price quoted by him does not include any element of excise duty, subject to production of exemption certificate. Where, however the prices, quoted are inclusive of excise duty, the percentage/ quantum of excise duty included in the quoted price should be specifically indicated in the tender.

6. **Payment Terms:** No advance payment will be made. Normally 100% payment is released within 30 days from the receipt of material.
7. Overwriting, scratching etc. must be avoided in the quotation. Any alterations in the figures shall be carried out by rewriting the whole figure & countersigned by authorized person from the firm.
8. The right to accept/reject any or all the offers, without giving any reason, is reserved.
9. The Bidder should also provide PAN/TAN/GIR No
10. You may contact us for any clarification on 25594894.

L. Confidentiality Clause

The following clause of confidentiality must be strictly adhered to by the vendor.

1. No party shall disclose any information to third party concerning the matters under this contract generally. In particular, any information identified as "PROPRIETARY" in nature by the disclosing party shall be kept strictly confidential by the receiving party and shall not be disclosed to any third party without the prior written consent of the original disclosing party.
2. "RESTRICTED INFORMATION" categories under section 18 of the Atomic Energy Act, 1962 and "OFFICIAL SECRETS" under section 5 of the official Secrets Act, 1923: Any contravention of the above mentioned provisions by any contractor, sub-contractor, consultant, advisor or the employees of a contractor will invite penal consequences under the aforesaid legislation.
3. Prohibition against the use of BARC's name without permission for publicity purposes:-The contractor or sub-contractor, consultant, advisor or the employees engaged by the contractor shall not use BARC's name for Publicity purpose through any public media like press, radio, T.V. or internet without the prior written approval of BARC. (Vide circular ref: 2/Misc-9/Lgl/2001/92 dated April 30, 2001).

Uyadao

Encl: Annexure- I

Annexure-IV
TECHNICAL COMPLIANCE PROFORMA

Sl. No.	Requirements	Compliance by Offered product (YES / NO)	Remarks
1.	Previous experience in fabrication and supply of products of similar nature		
2.	Have necessary arrangement to vibration isolation efficiency test of isolation table & test report?		
3.	All items in the respective quantities offered, as per point no. C in annexure-I.		
4.	Supplier agreeable to accommodate for minor changes in design of mechanical components before fabrication?		
5.	Supplier agreeable to refabricate components deemed technical unsuitable during inspection?		
6.	Have test equipment to test spring constant & its test certificate?		
7.	Any deviation in the technical specifications detailed in annexure-I?		

**** Note: Indenting Officer may visit Vendors site for verification/evaluation of supplier's capability.**

Signature and Seal of
Authorized signatory for the
Supplier

cyados

BILL OF MATERIAL

ITEM NO.	PART NO.	DESCRIPTION	MATL.	QTY.	DRG. NO.	REMARKS
100	-	VIBRATION ISOLATION TABLE	-	01	THIS DWG	-
-	101	TOP PLATE 770 x 385 x 2 mm THK	MAGNETIC SS 410	02	101	-
-	102	COUNTERSINK FLAT HEAD SCREW M3, 6mm LG	SS 304	20	STD.	-
-	103	TOP SIDE COVER 750 x 108 x 2 mm THK	MS	04	103	-
-	104	FRAME FIXING STUD	SS 304	04	104	-
-	105	TOP PLATE SUPPORT STUD I2 DIA 108 LONG	SS 304	04	105	-
-	106	BASE PLATE 770 x 770 x 10 mm THK	MS	01	106	-
-	107	SIDE COVER 650 x 550 x 2 mm THK	MS	03	107	-
-	108	TABLE DOOR	MS	02	108	-
-	109	BOTTOM PLATE	SS 304	01	109	-
-	110	M3 SOCKET HEAD SCREW M3, 6mm LONG	SS 304	52	STD	-
-	120	TABLE FRAME ASSM	MS	01	120	-
-	150	SPRING FRAME ASSM	-	01	150	-
-	200	LEAF SPRING ASSM	-	06	-	AS PER GUIDANCE
-	220	WHEEL ASSM	-	04	STD	AS PER GUIDANCE
-	250	HEIGHT ADJUSTMENT ASSM	-	04	-	AS PER GUIDANCE

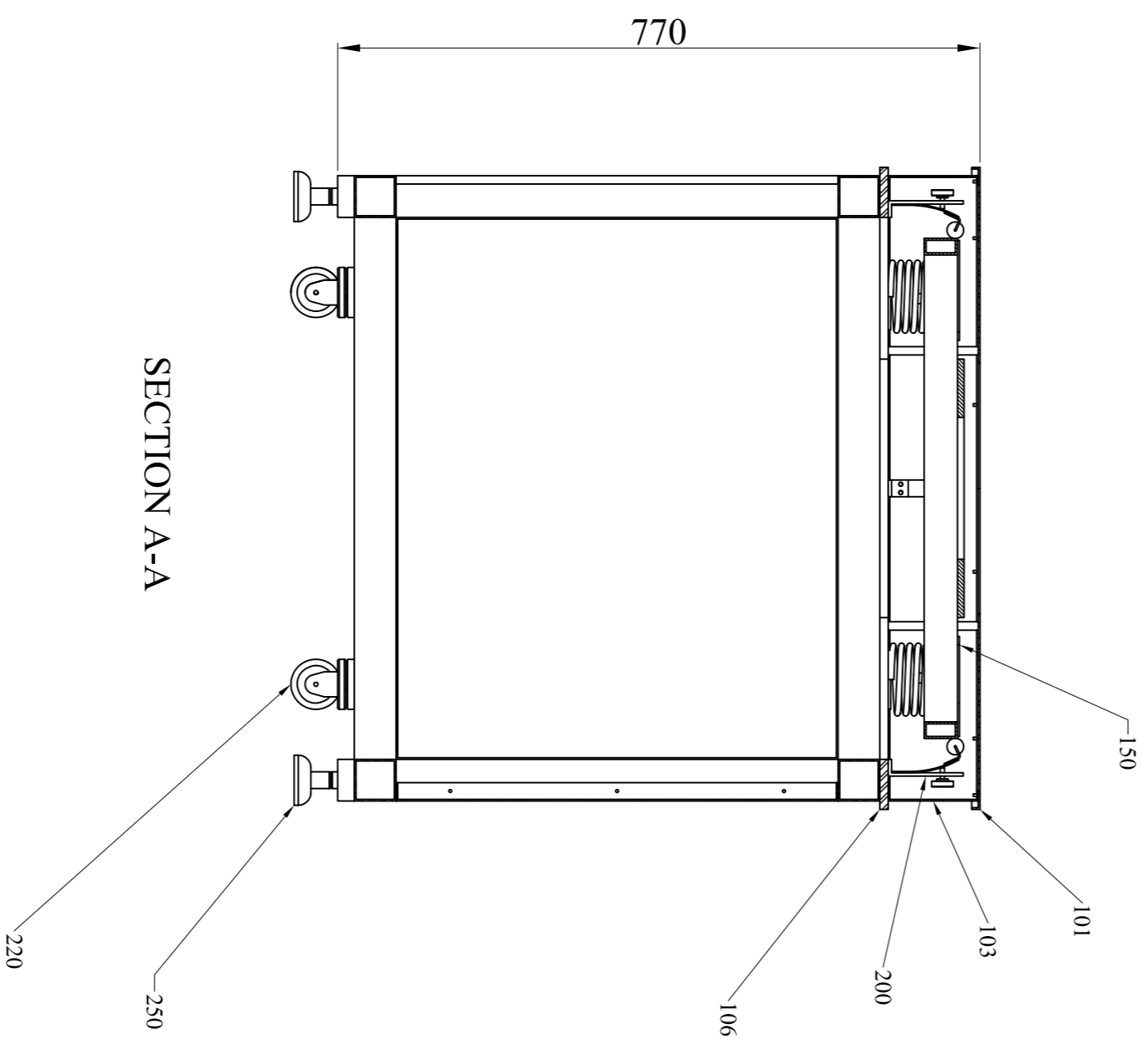
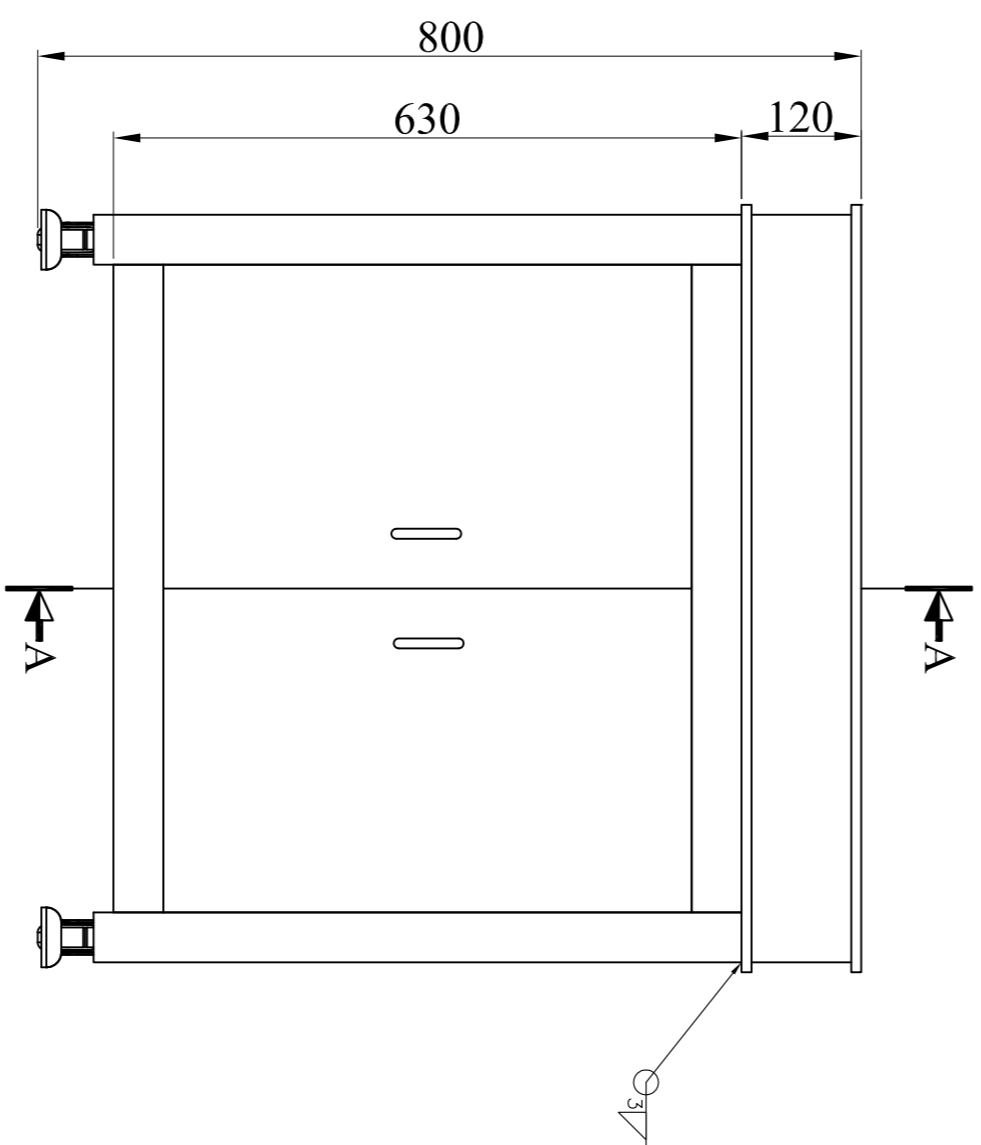
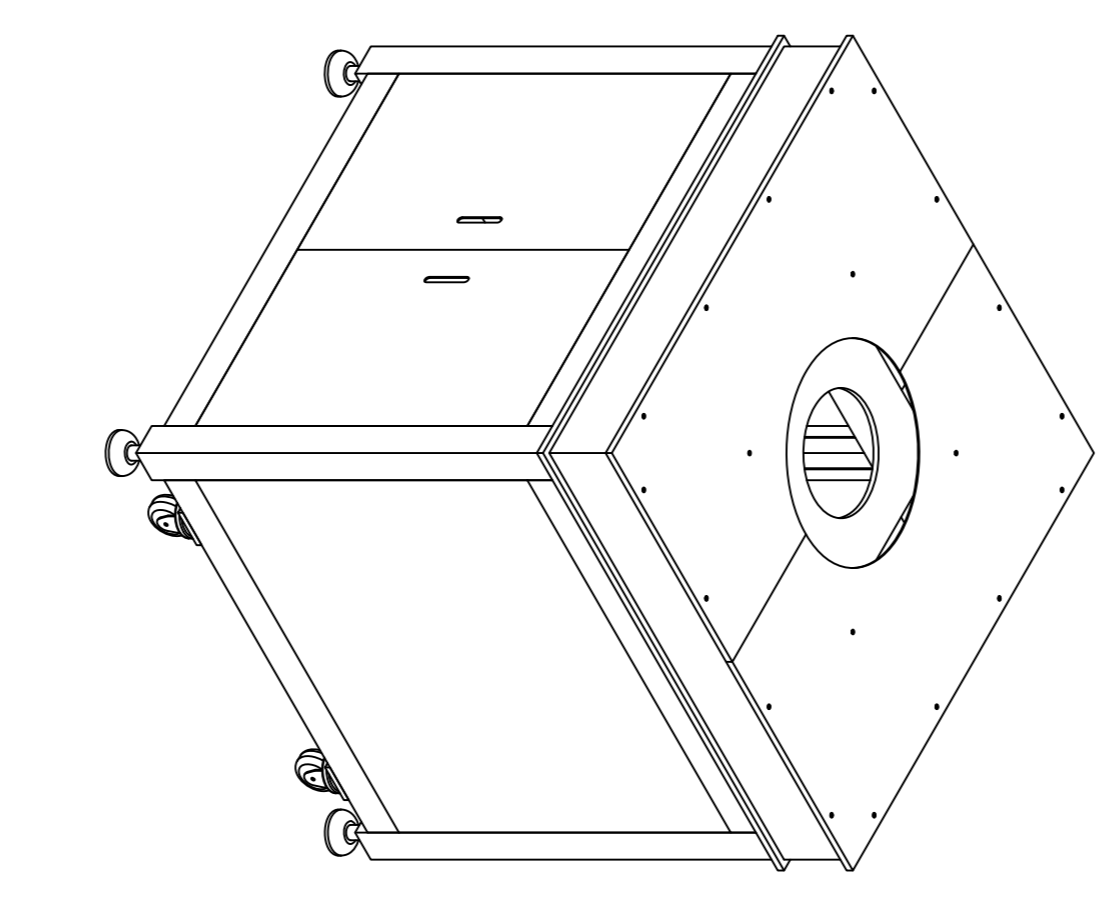
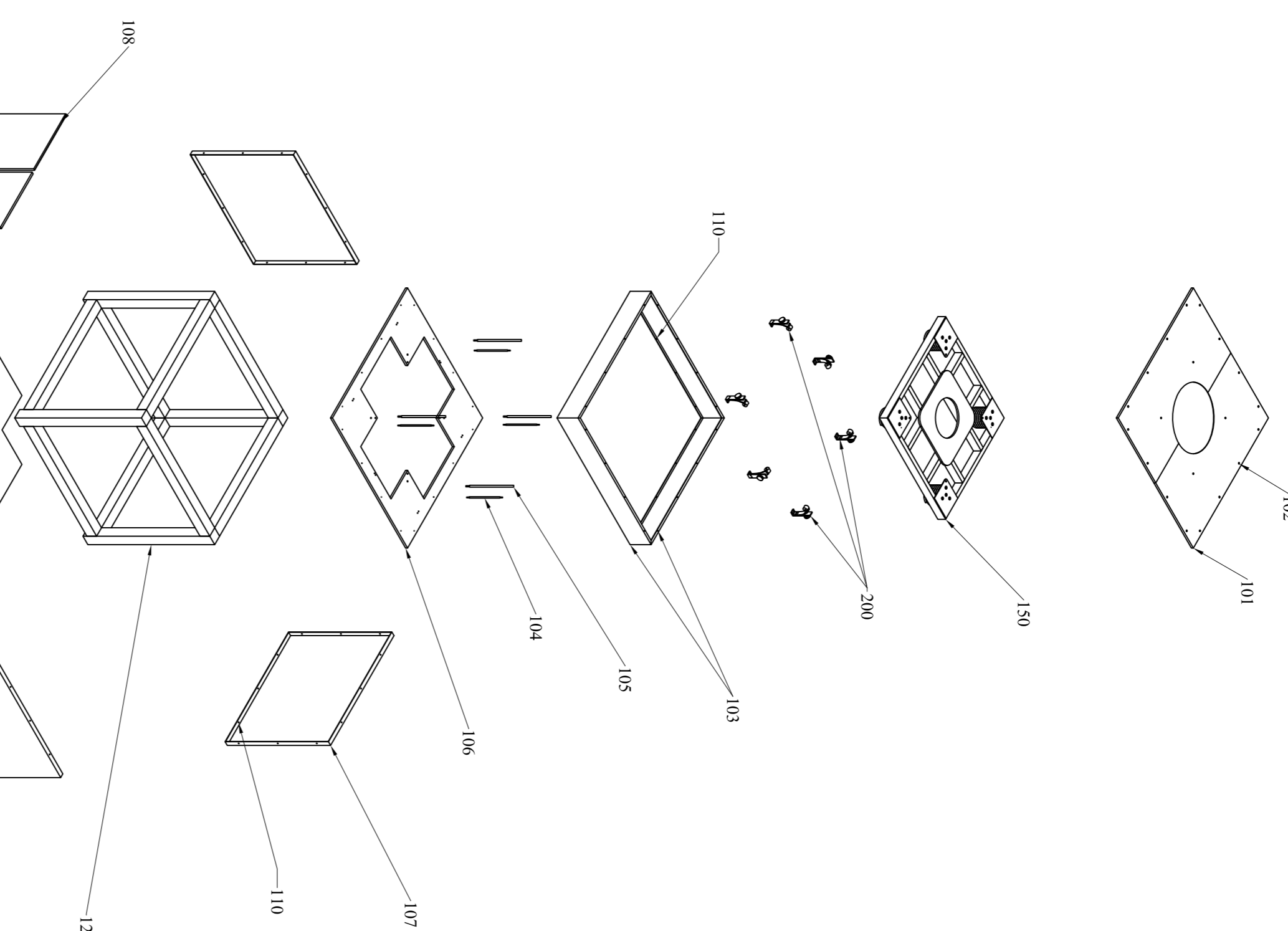
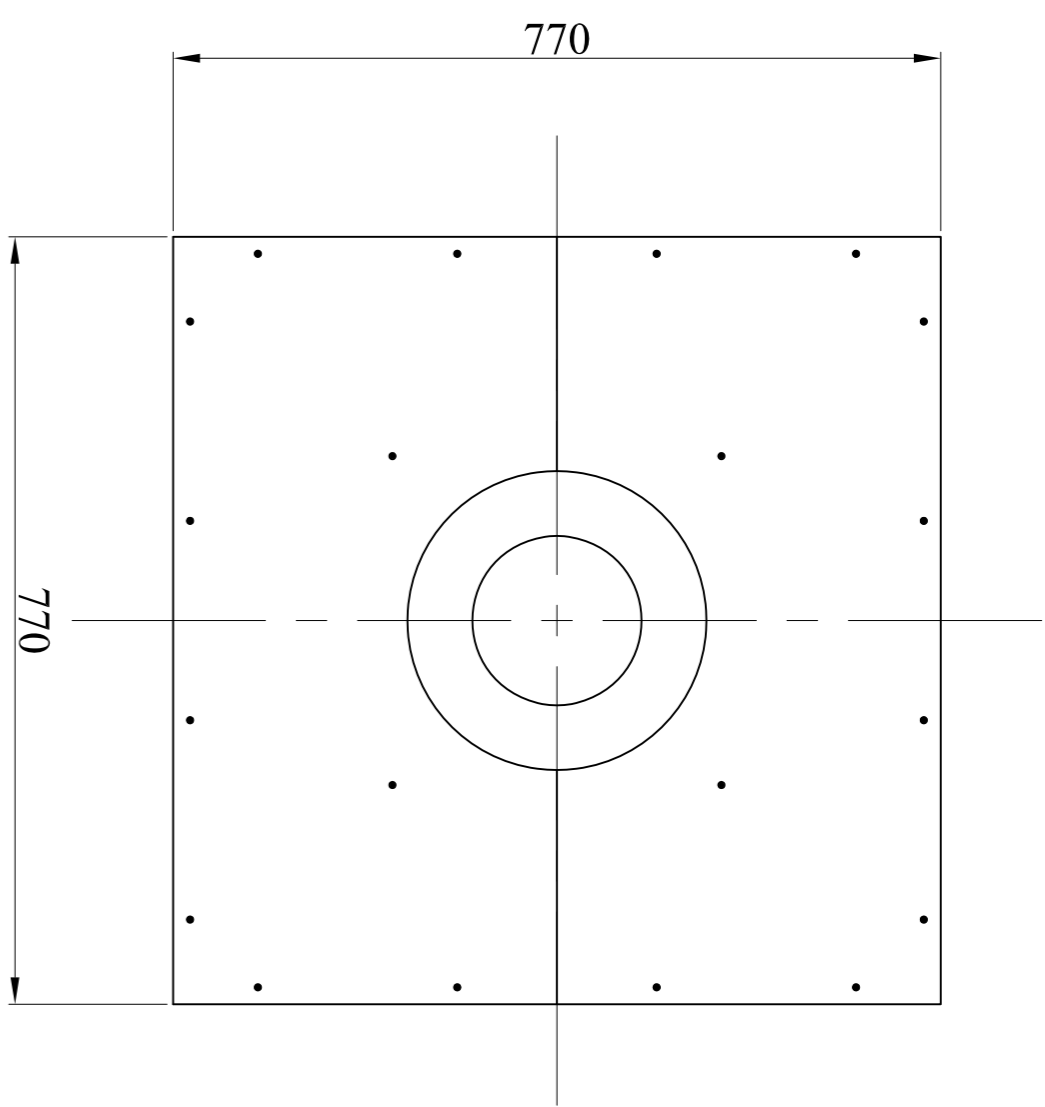

DRG. NO. **B-100** REV. **0**

REFERENCE DRAWINGS

DRG. NOS.

NO. LOC.

REVISIONS

DESCRIPTION

DRN. DATE

APP'D

GENERAL TOLERANCE (UNLESS OTHERWISE SPECIFIED SHOULD CONFORM TO IS: 2102 VIZ. (MEDIUM CLASS) FOR MACHINED WORK DIMENSIONS.

LINEAR DIMENSIONS

LENGTH OF SHORTER

SURFACE FINISH IN MICRONS 3.15 \sqrt{CLA} CHAMFER 1 x 45°

NOTES:

PROJECT OR SECTION: **SEM** TITLE: **VIBRATION ISOLATION TABLE ASSM**

DRN.: J.S. YADAV DATE: 16 MARCH 2020

DRG. CHKD.: DATE: DES. CHKD.:

GOVERNMENT OF INDIA

BHABHA ATOMIC RESEARCH CENTRE

SECURITY ELECTRONICS & SOFTWARE SYSTEM DIVISION

DRG. NO.: **B-100**

PROJECTION: REV. **0**

8

7

6

5

4

2

1

ANNEXURE- II

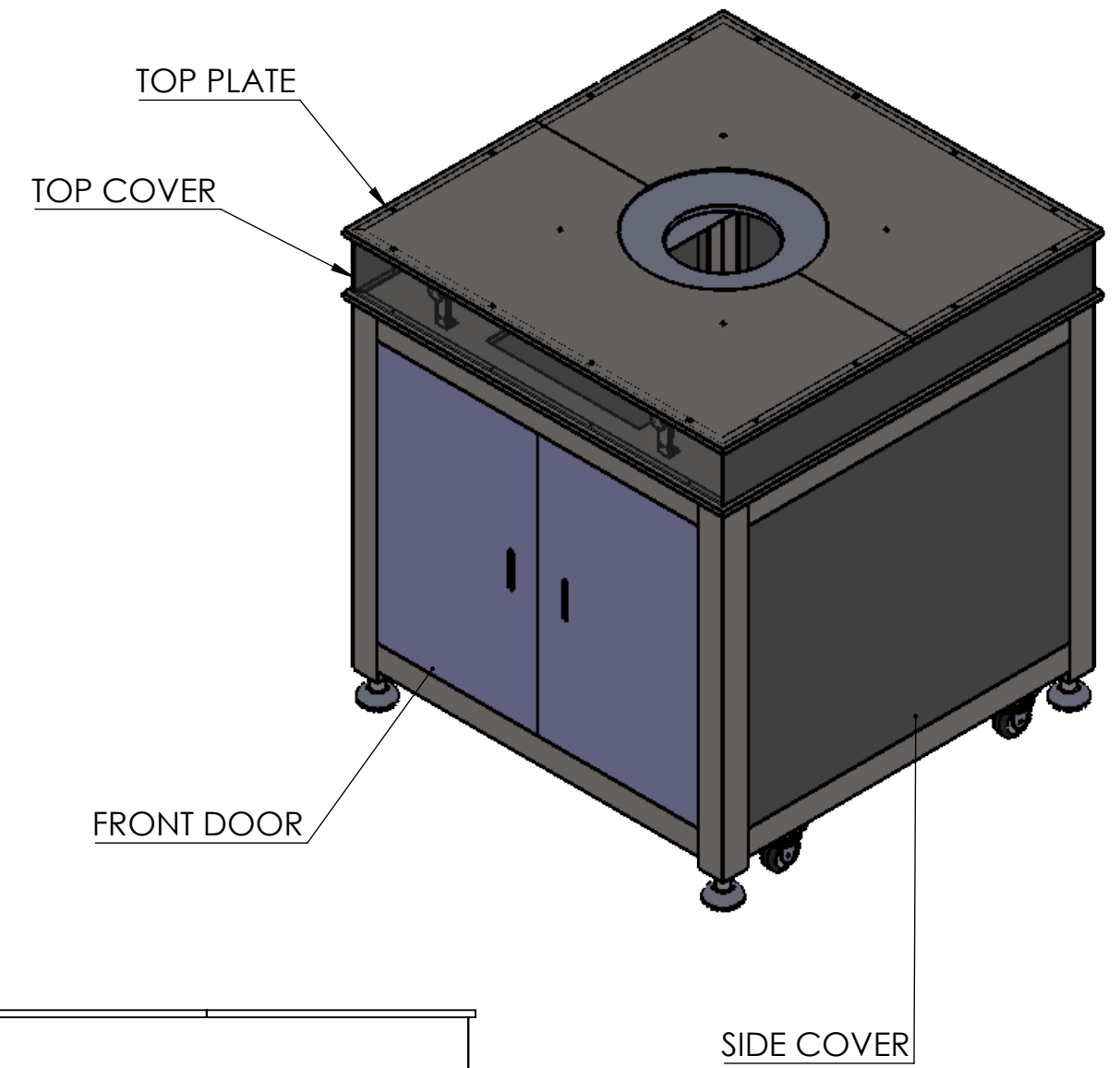
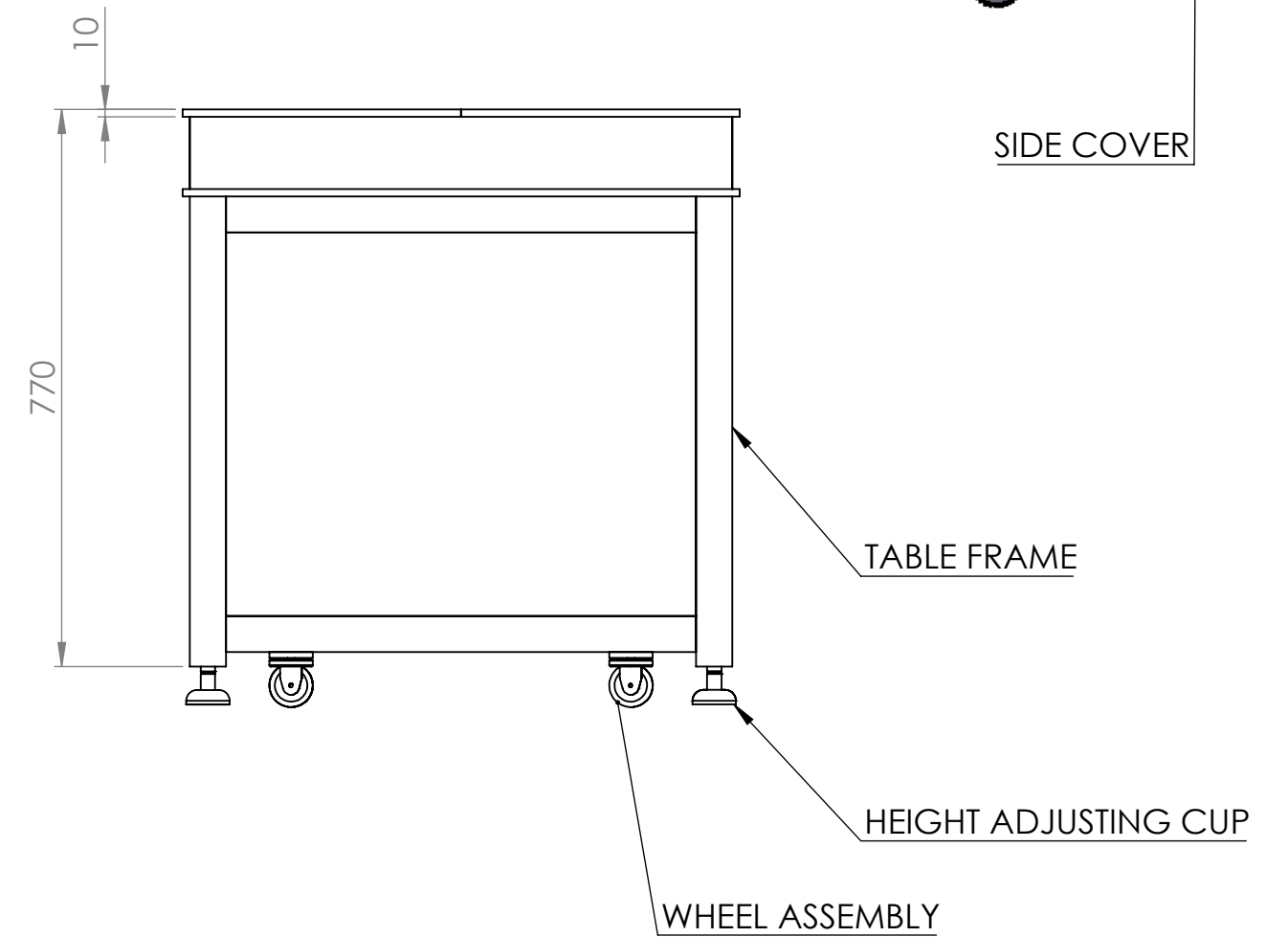
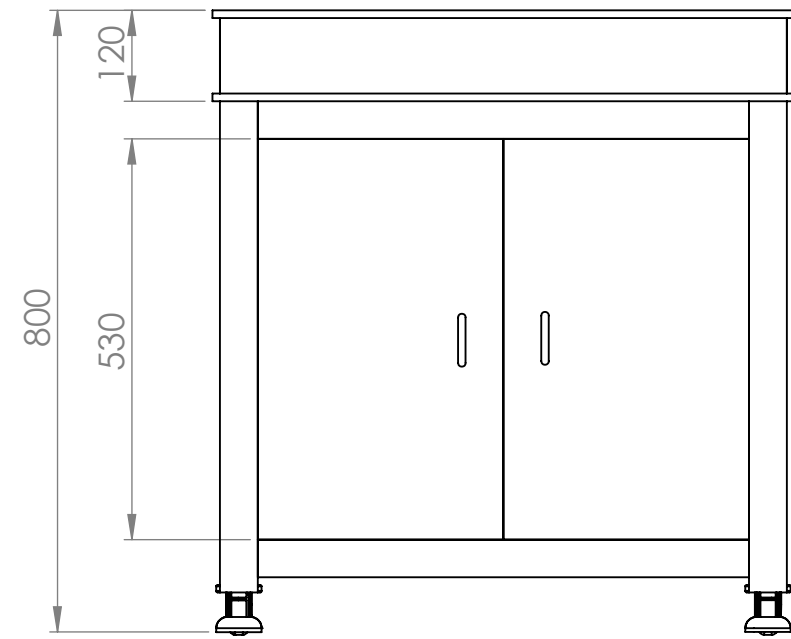
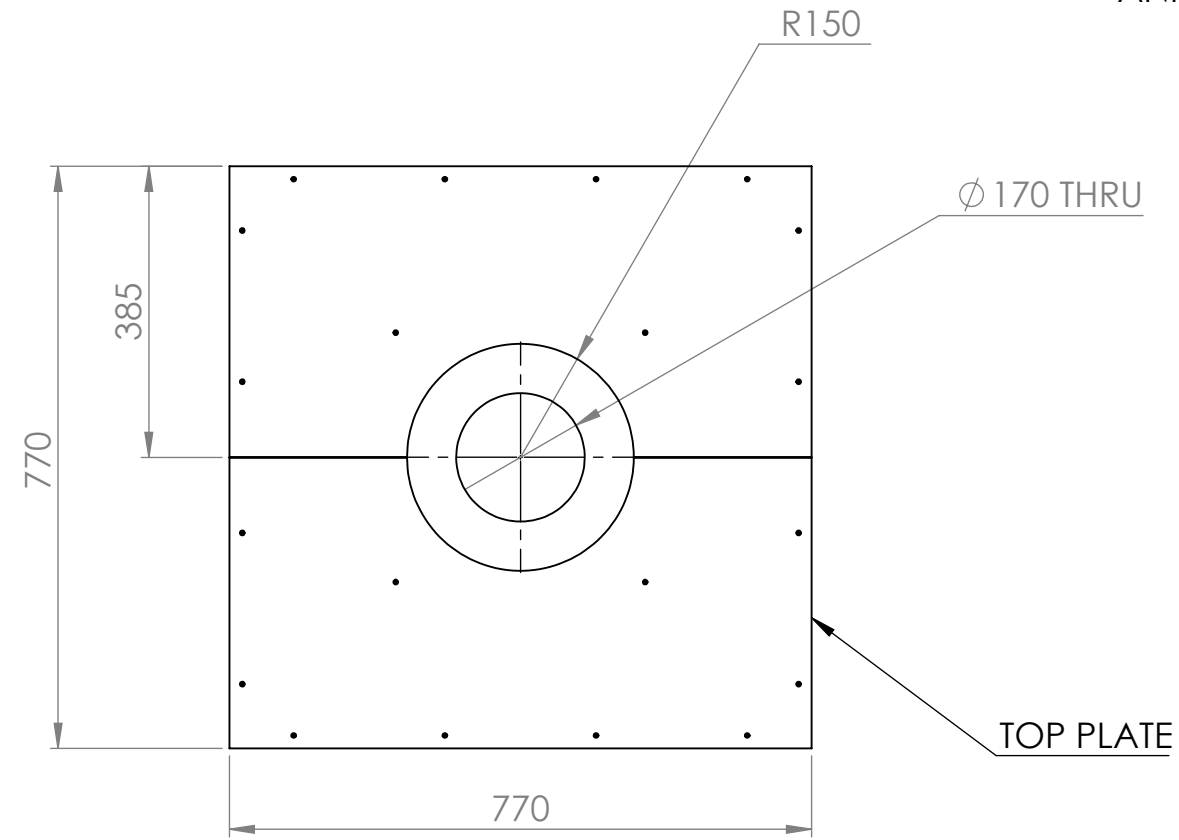

ANNEXURE- III

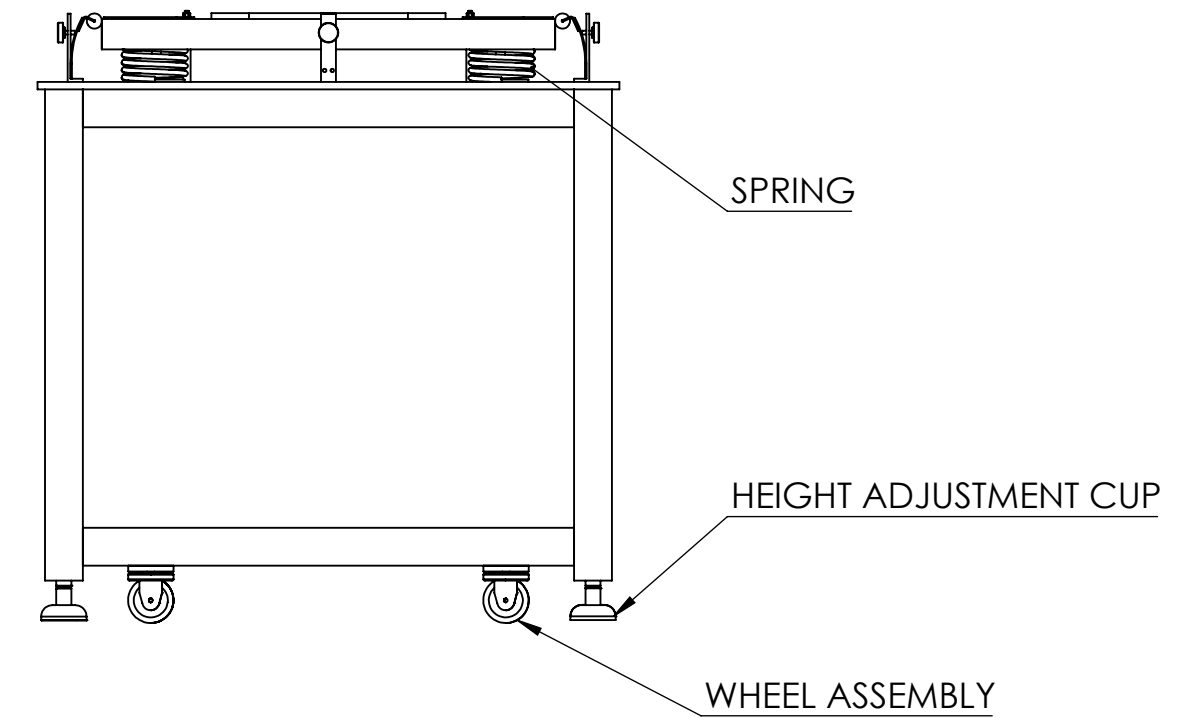
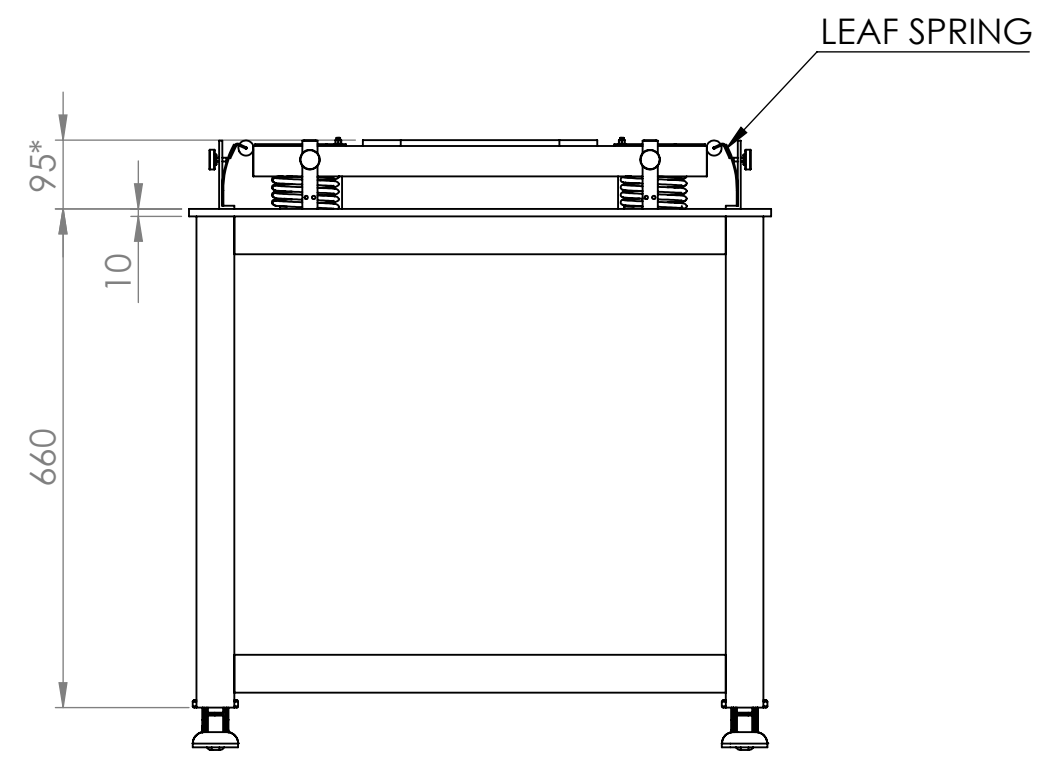
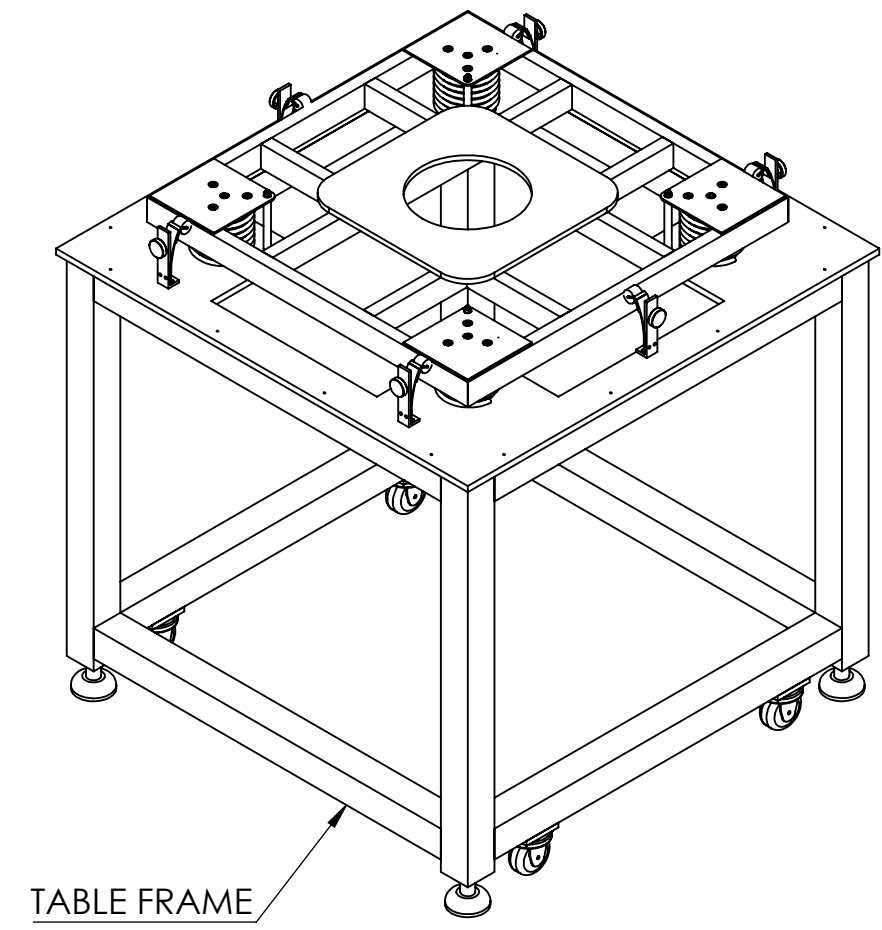
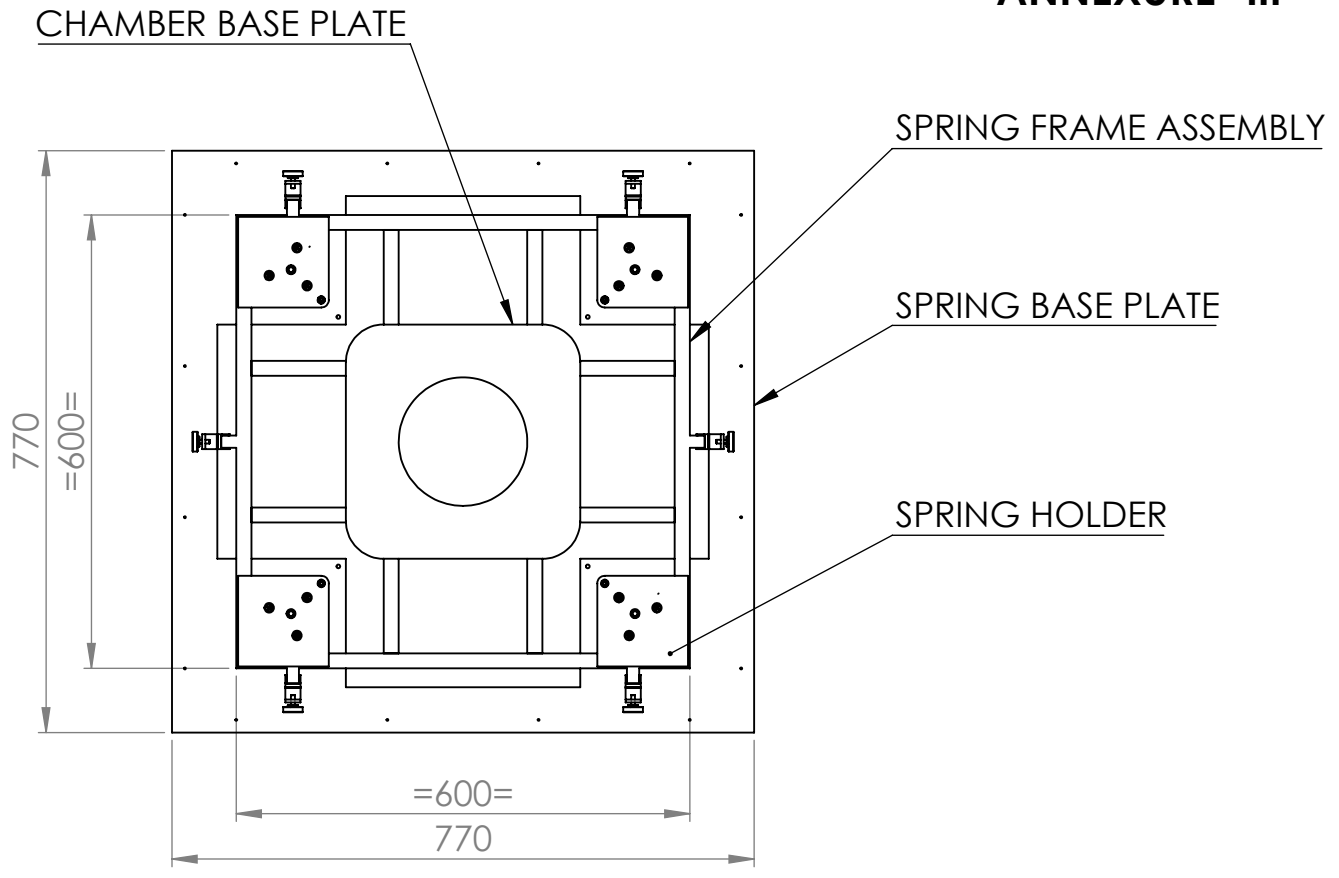

*DIMENSION SHOWN IS IN APPLIED LOAD CONDITION OF 120Kg ON THE CHAMBER BASE PLATE.

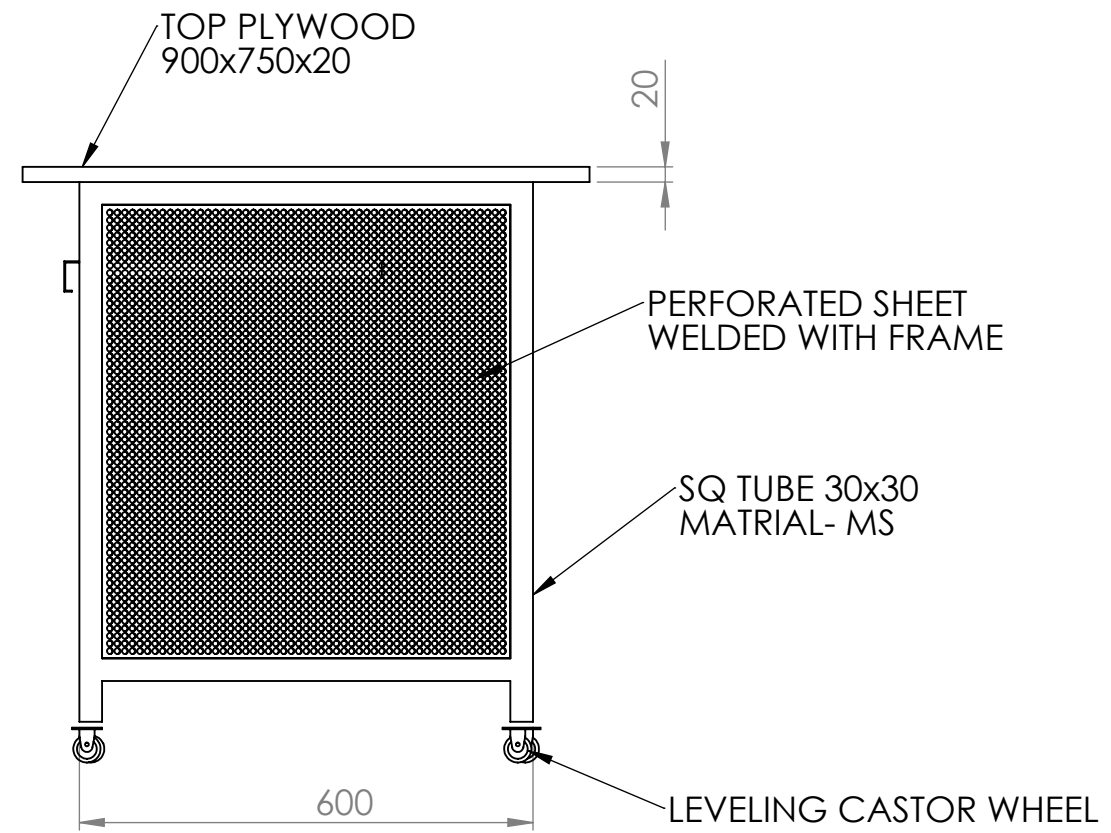
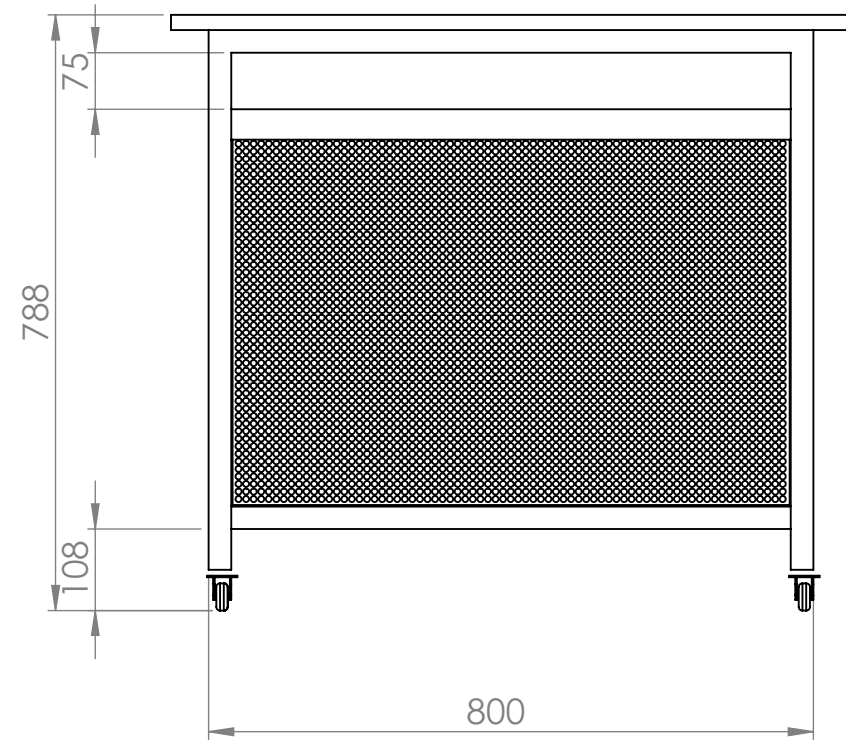
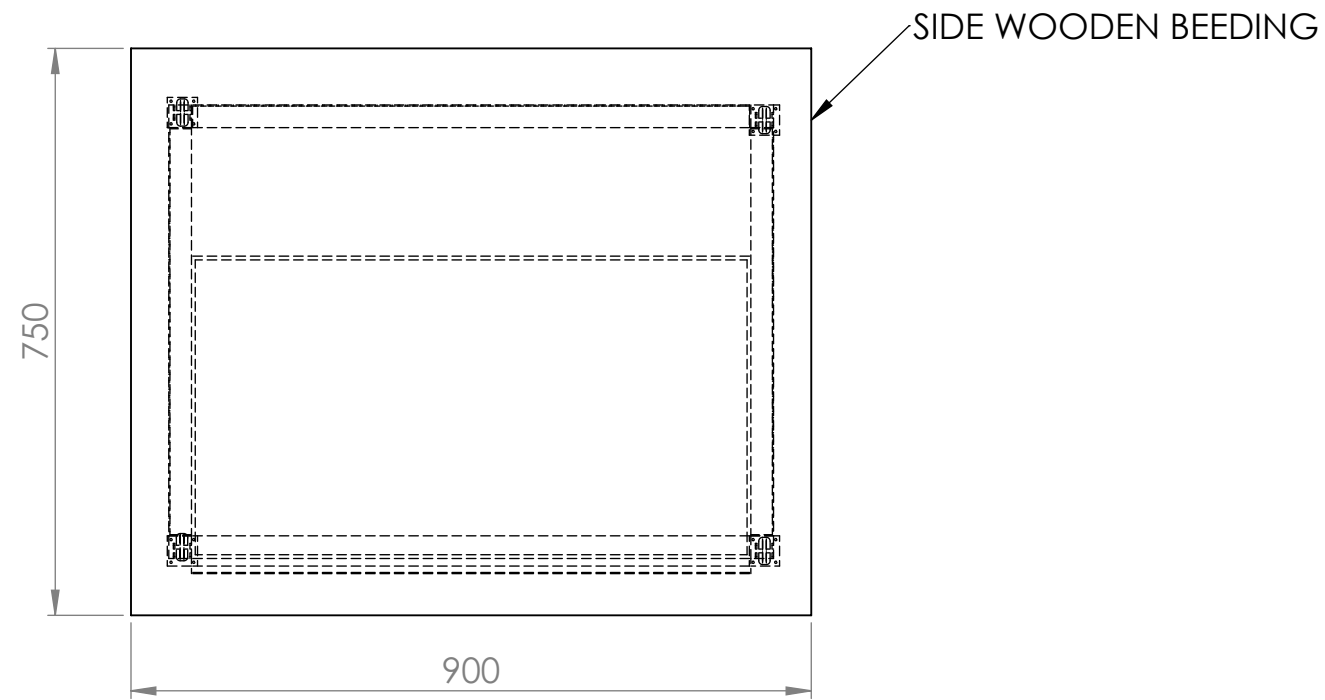

COMPUTER TABLE

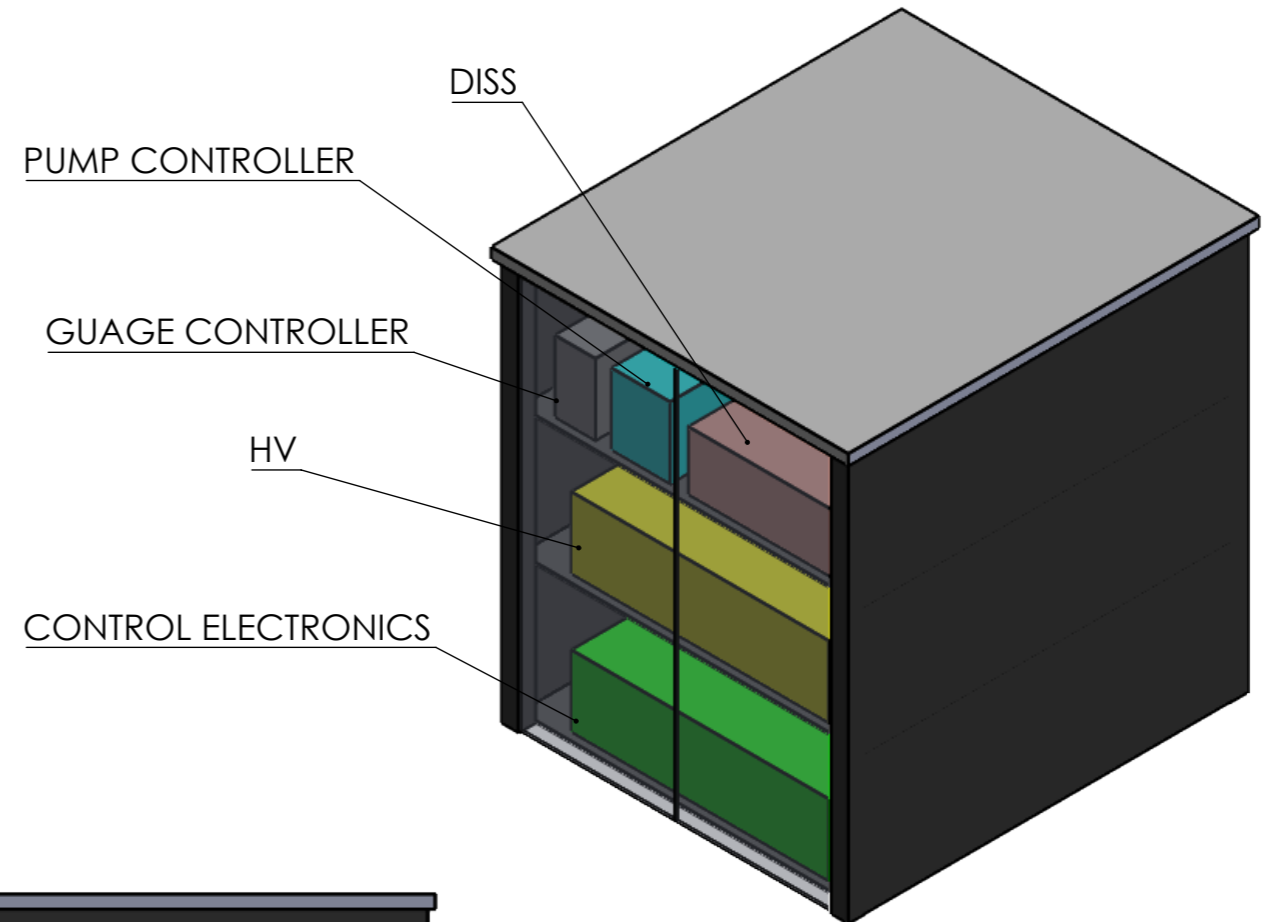
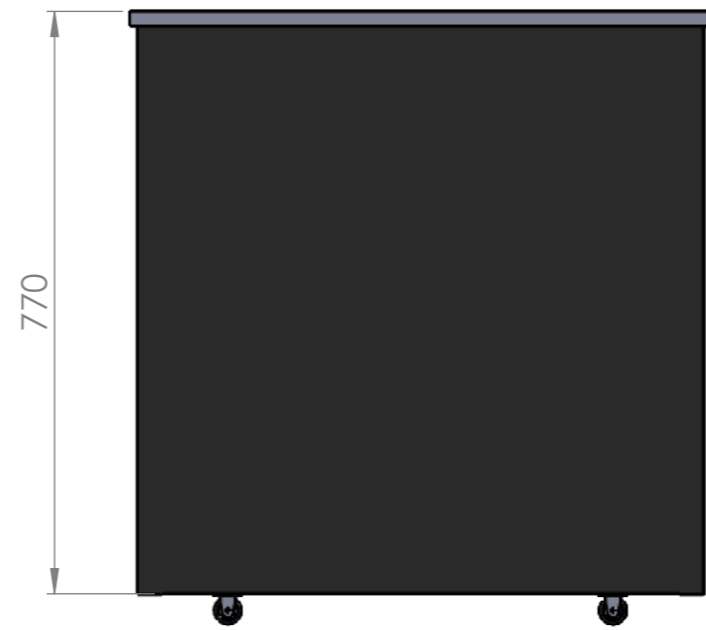
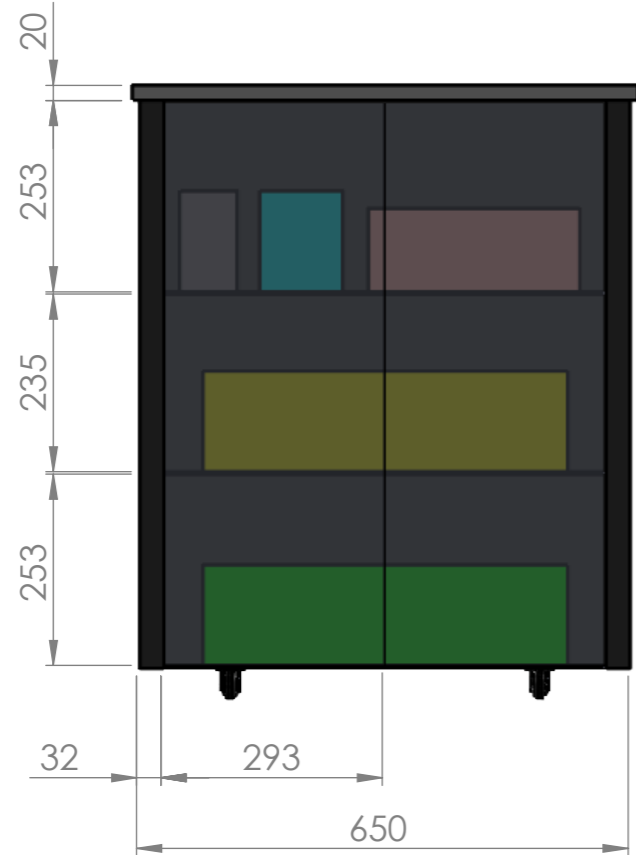
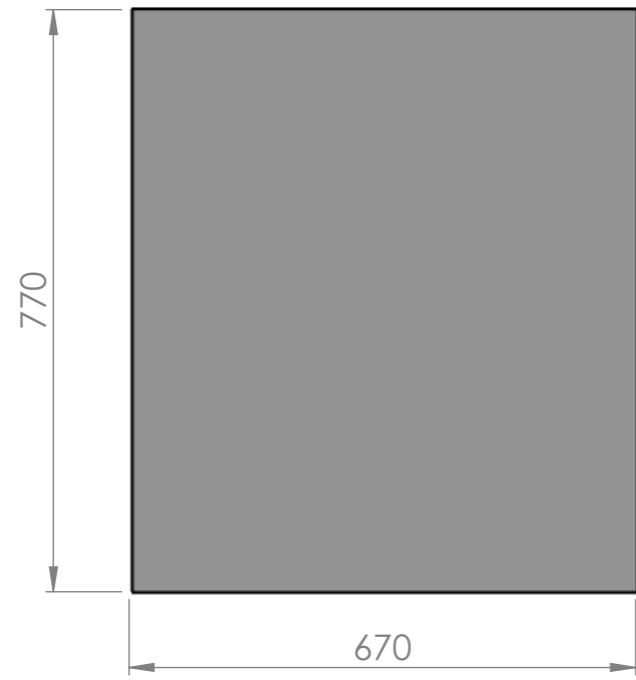

UNLESS OTHERWISE SPECIFIED: DIMENSIONS ARE IN MILLIMETERS SURFACE FINISH: TOLERANCES: LINEAR: ANGULAR:			FINISH:		DEBURR AND BREAK SHARP EDGES		DO NOT SCALE DRAWING		REVISION		
						TITLE: rack assm					
DRAWN						DWG NO.					
CHK'D						SCALE:1:10					
APPV'D						SHEET 1 OF 1					
MFG						A3					
Q.A						WEIGHT:					

BILL OF MATERIAL

ITEM NO.	PART NO.	DESCRIPTION	MATL.	QTY.	DRG. NO.	REMARKS
01	151	SPRING FRAME	MS	01	151	-
02	152	CHAMBER BASE PLATE	MS	01	152	-
03	153	BRACKET	MS	04	153	-
04	154	SPRING	..	04	STD	-
05	155	DISC FOR SPRING	Al	04	155	-
06	156	M6 C'SUNK HEAD SCREW	SS	12	STD	-
07	157	UPPER SPRING DISC	MS	04	157	-

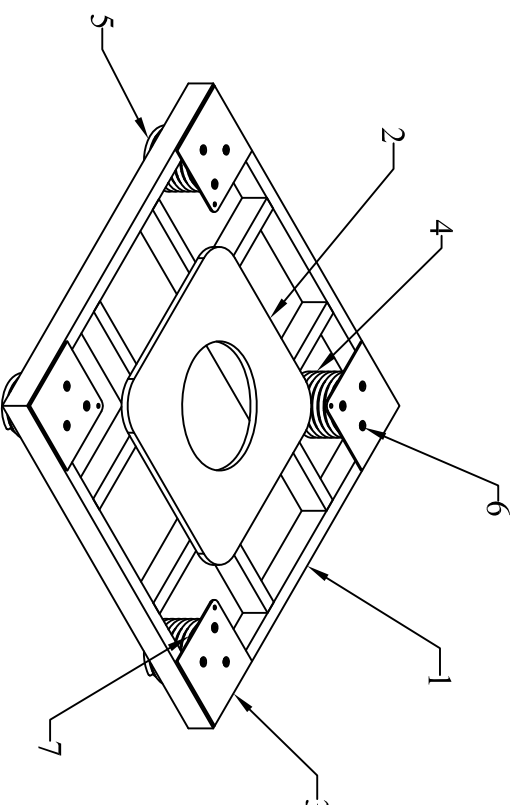
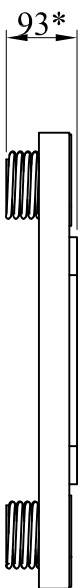
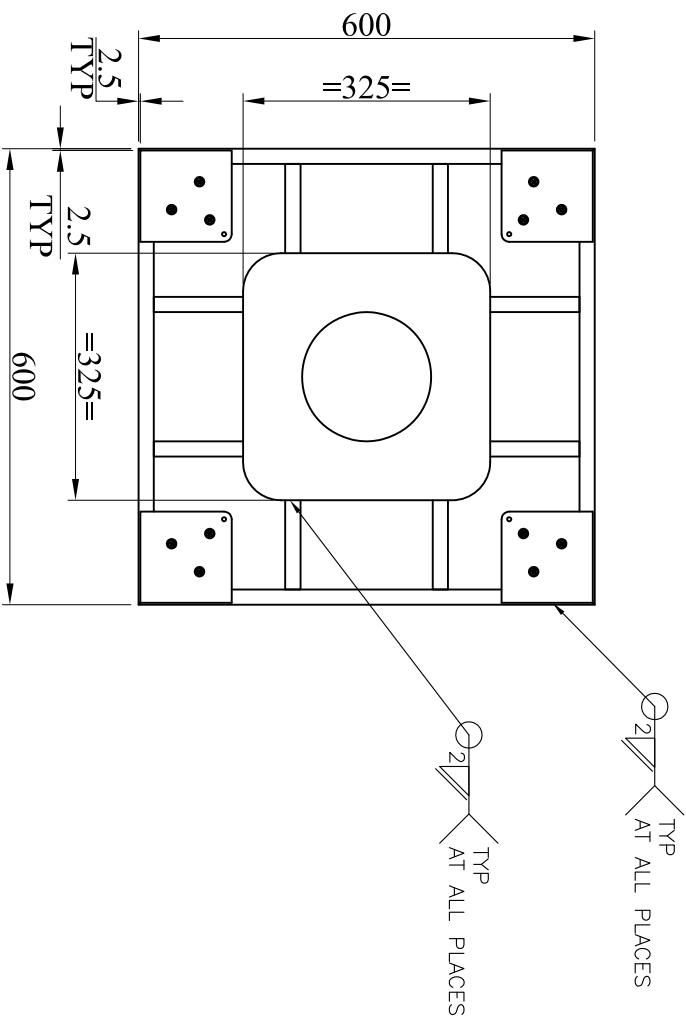

NOTE
FILLET WELD AT ALL BRACKETS AND CHAMBER BASE PLATE TO SPRING FRAME
TO GET MAXIMUM STRENGTH.
* DIMENSION IN COMPRESSED SPRING POSITION.
IF ANY DOUBT, ASK.

GENERAL TOLERANCE UNLESS OTHERWISE SPECIFIED

LINEAR DIMENSIONS	LENGTH OF SHORTER SIDE OF ANGLE
UPTO - 6 ± 0.1	1 - 6 ± 1°
6 - 30 ± 0.2	6 - 30 ± 0.30°
30 - 120 ± 0.3	30 - 120 ± 0.20°
120 - 315 ± 0.5	
315 - 1000 ± 0.8	

NOTES:-
1. ALL DIMENSIONS ARE IN MILLIMETRES.
2. REMOVE SHARP CORNERS AND BURRS.

SURFACE FINISH
IN MICRONS 3.15/CLA
CHAMFER 1 x 45°

NO.	LOC.	DESCRIPTION	REVISIONS

DRN.	APP'D	DATE

PROJECT OR SECTION :
SEM
SESSD
DRN./DATE yadavjs
DRG. CHK'D.
DESD.

TITLE
SPRING FRAME ASSEM
GOVERNMENT OF INDIA
BHABHA ATOMIC RESEARCH CENTRE
SECURITY ELECTRONICS & SOFTWARE SYSTEM DIVISION

APP'D.
SHEET NO 1 OF 1 SHEETS
SCALE:- 1 : 10
PROJECTION: THIRD ANGLE
DRG. NO. D-150
REV. 02

THIS DESIGN AND DRAWING IS THE PROPERTY OF BHABHA ATOMIC RESEARCH CENTRE
IT MUST BE RETURNED WITH QUOTATION OR UPON DELIVERY OF MATERIAL AND
EQUIPMENT MUST NOT BE USED EXCEPT BY PERMISSION OF THE OWNER.

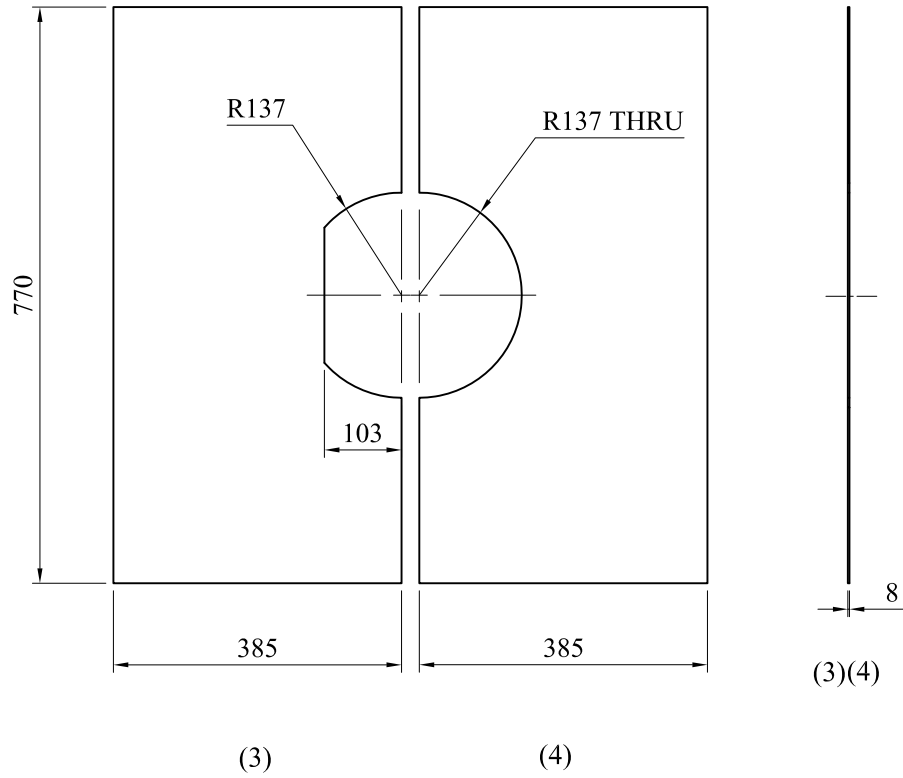
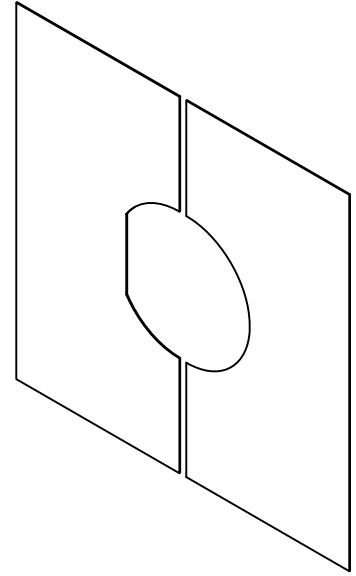

QUANTITY- 1-1 Nos both

					MATERIAL : GLASS
NO.	LOC.	DESCRIPTION			Auto-CAD FILE NO. ..
REVISIONS			DRN. / DATE	APP'D./DATE	CODE NO.: ..
PROJECT OR SECTION :		TITLE		APP'D. YV Chaudhary	
SEM		GLASS TOP 1&2		SCALE:- 1:10	
DR'N. yadavjs	DATE	03/02/2022	PROJECTION: THIRD ANGLE		
DRG. CHK'D. NK Y	DATE	..	GOVERNMENT OF INDIA		DRG. NO.
DES'D. ..	DES'D. CHK'D. ..	BHABHA ATOMIC RESEARCH CENTRE		E- 101 (3)(4)	REV.
			SECURITY ELECTRONICS & SOFTWARE SYSTEM DIVISION		0

THIS DESIGN AND DRAWING IS THE PROPERTY OF BHABHA ATOMIC RESEARCH CENTRE
 IT MUST BE RETURNED WITH QUOTATION OR UPON DELIVERY OF MATERIAL AND
 EQUIPMENT MUST NOT BE USED EXCEPT BY PERMISSION OF THE OWNER.

DrgBD.dwg

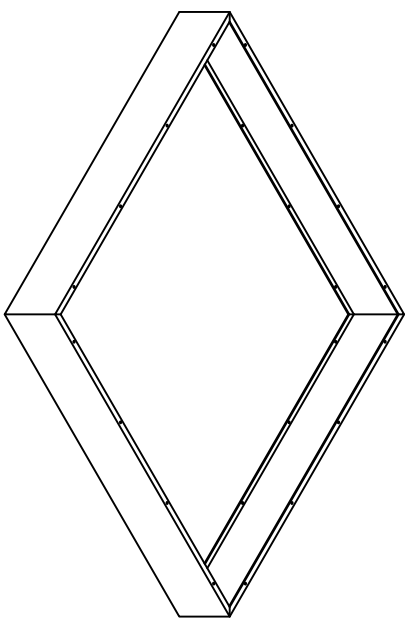
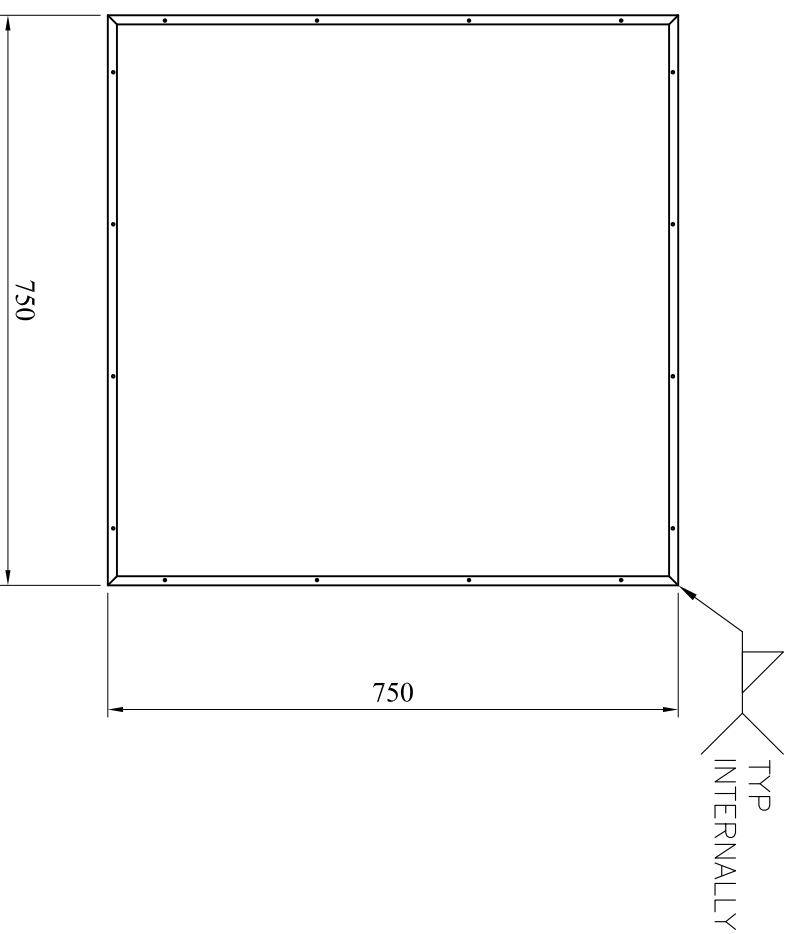
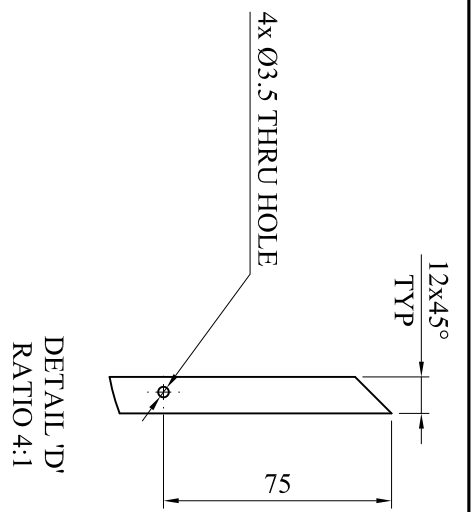
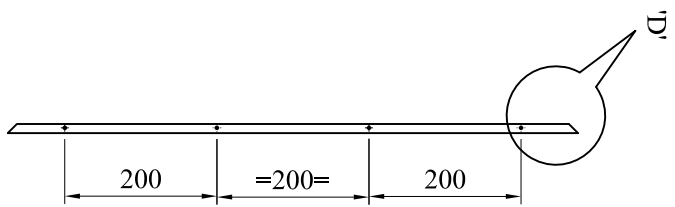
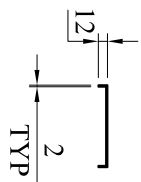
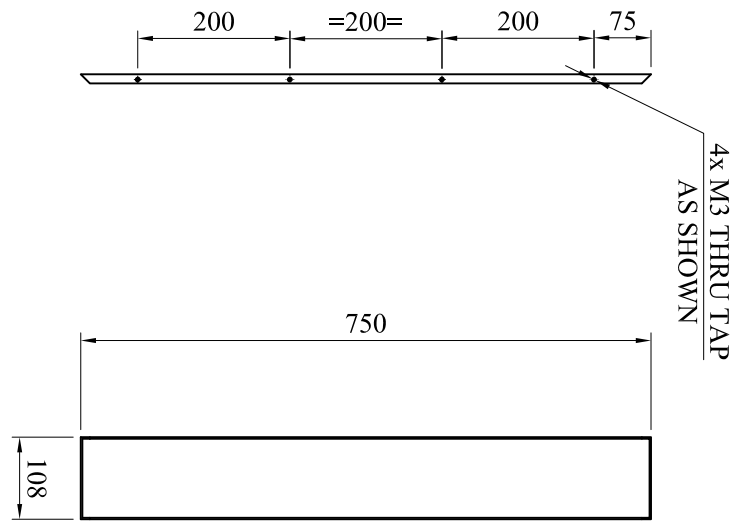

GENERAL TOLERANCE UNLESS OTHERWISE SPECIFIED

LINEAR DIMENSIONS	LENGTH OF SHORTER SIDE OF ANGLE
UPTO - 6 ± 0.1	1 - 6 ± 1°
6 - 30 ± 0.2	6 - 30 ± 0.30°
30 - 120 ± 0.3	30 - 120 ± 0.20°
120 - 315 ± 0.5	
315 - 1000 ± 0.8	

NOTES:-
 1. ALL DIMENSIONS ARE IN MILLIMETRES.
 2. REMOVE SHARP CORNERS AND BURRS.

SURFACE FINISH IN MICRONS 3.15√CLA
 CHAMFER 1 x 45°

NO.	LOC.	DESCRIPTION	DRN. DATE	APP'D

PROJECT OR SECTION :
 SEM
 VIBRATION ISOLATION TABLE

DRN./DATE yadavjs
 DRG. CHK'D. NKY
 DES'D.

TITLE
TOP COVER

GOVERNMENT OF INDIA
 BHABHA ATOMIC RESEARCH CENTRE
 SECURITY ELECTRONICS & SOFTWARE SYSTEM DIVISION

MATERIAL: MS
 SHEET NO 1 OF 1 SHEETS
 SCALE:- 1:10
 PROJECTION: THIRD ANGLE
 DRG. NO. D-103
 REV. ..

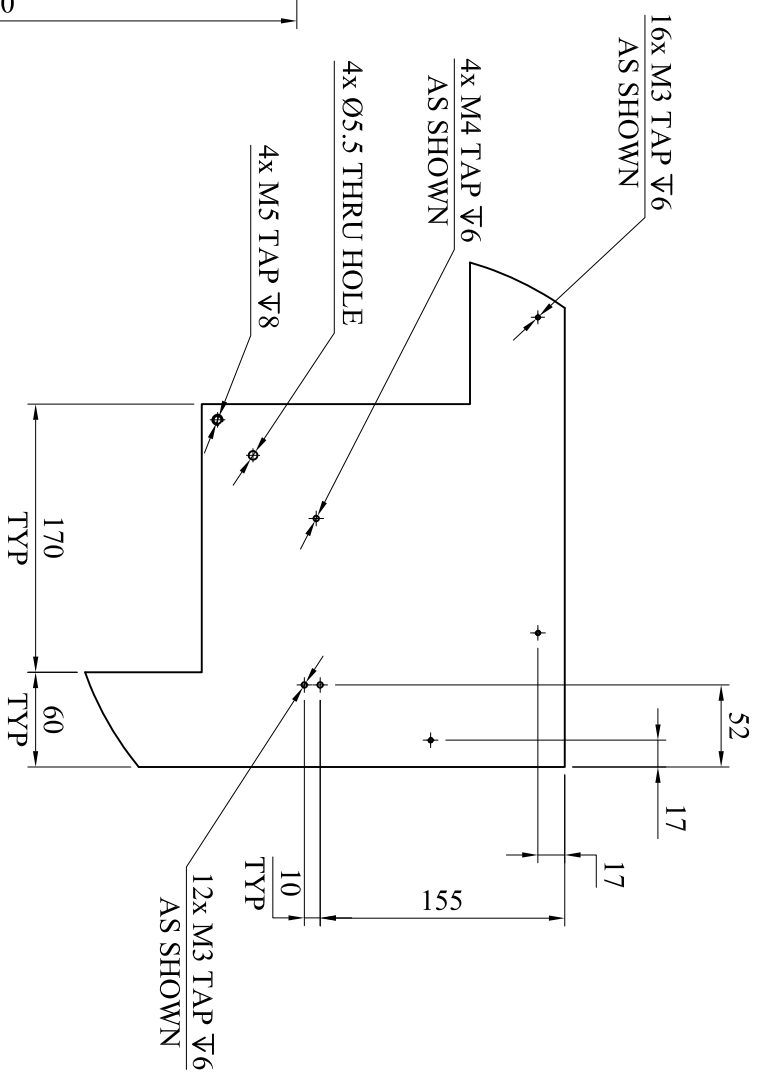
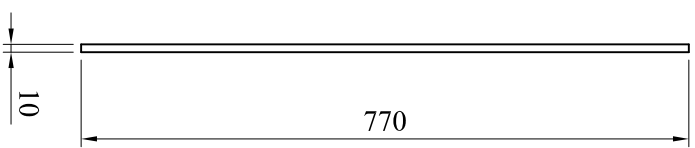
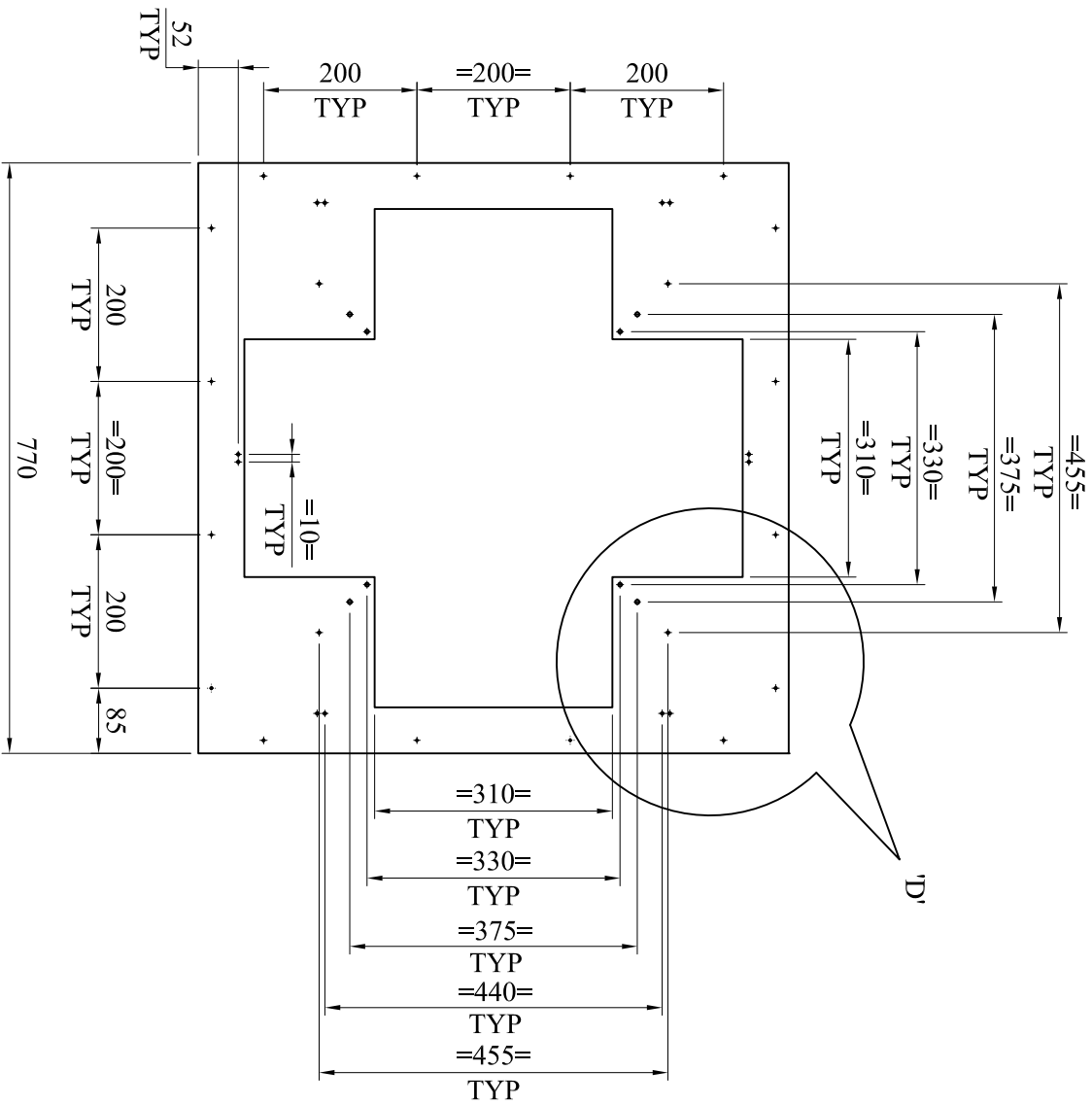

DETAIL 'D'
RATIO 2:1

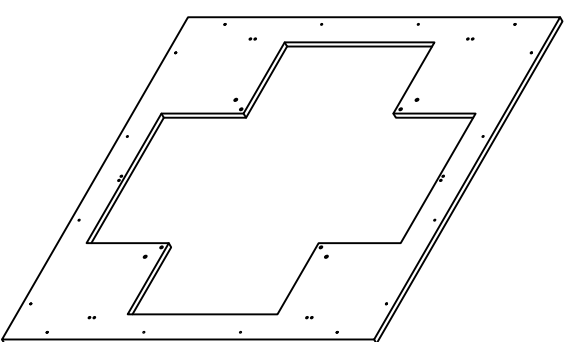

GENERAL TOLERANCE UNLESS OTHERWISE SPECIFIED

LINEAR DIMENSIONS	LENGTH OF SHORTER
UPTO - 6 ± 0.1	SIDE OF ANGLE
6 - 30 ± 0.2	1 - 6 ± 1°
30 - 120 ± 0.3	6 - 30 ± 0.30°
120 - 315 ± 0.5	30 - 120 ± 0.20°
315 - 1000 ± 0.8	

NOTES:-
 1. ALL DIMENSIONS ARE IN MILLIMETRES.
 2. REMOVE SHARP CORNERS AND BURRS.

SURFACE FINISH
 IN MICRONS 3.15√CLA
 CHAMFER 1 x 45°

NO.	LOC.	DESCRIPTION	REVISIONS

DRN.	APP'D	DATE

PROJECT OR SECTION :
SEM

VIBRATION ISOLATION TABLE

DRN./DATE yadav/s

DRG. CHK'D. NKY

DES'D.

TITLE
BASE PLATE

GOVERNMENT OF INDIA
 BHABHA ATOMIC RESEARCH CENTRE
 SECURITY ELECTRONICS & SOFTWARE SYSTEM DIVISION

MATERIAL: MS

SHEET NO 1 OF 1 SHEETS

SCALE:- 1:10

PROJECTION: THIRD ANGLE

DRG. NO. D-106

REV. ..

THIS DESIGN AND DRAWING IS THE PROPERTY OF BHABHA ATOMIC RESEARCH CENTRE
IT MUST BE RETURNED WITH QUOTATION OR UPON DELIVERY OF MATERIAL AND
EQUIPMENT MUST NOT BE USED EXCEPT BY PERMISSION OF THE OWNER.

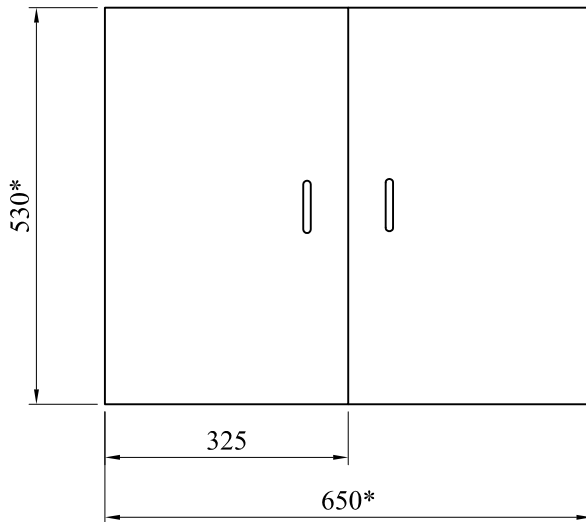
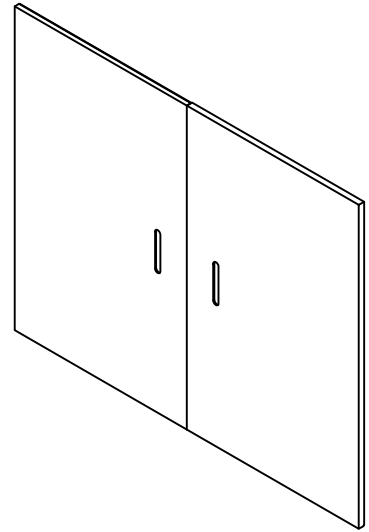
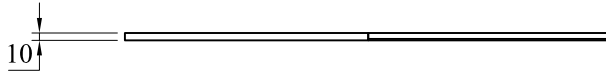

* MAXIMUM SPACE AVAILABLE FOR DOOR.
USE OF HOOKS, HOLDERS, AND FINAL DESIGN IS UP TO YOU,
SHOULD BE COMPATIBLE IN TABLE AND GOOD LOOKING.
IF ANY DOUBT, ASK.

					MATERIAL :..
NO.	LOC.	DESCRIPTION			Auto-CAD FILE NO. ..
REVISIONS			DRN. / DATE	APP'D./DATE	CODE NO.: ..
PROJECT OR SECTION :		TITLE			APP'D. yvch
SEM TABLE		DOOR			SCALE:- 1:10
DR'N. yadavjs	DATE ..				PROJECTION: THIRD ANGLE
DRG. CHK'D. NKYadav	DATE ..	GOVERNMENT OF INDIA			DRG. NO.
DES'D. ..	DES'D. CHK'D. ..	BHABHA ATOMIC RESEARCH CENTRE			E- 108
		SECURITY ELECTRONICS & SOFTWARE SYSTEM DIVISION			

THIS DESIGN AND DRAWING IS THE PROPERTY OF BHABHA ATOMIC RESEARCH CENTRE
IT MUST BE RETURNED WITH QUOTATION OR UPON DELIVERY OF MATERIAL AND
EQUIPMENT MUST NOT BE USED EXCEPT BY PERMISSION OF THE OWNER.

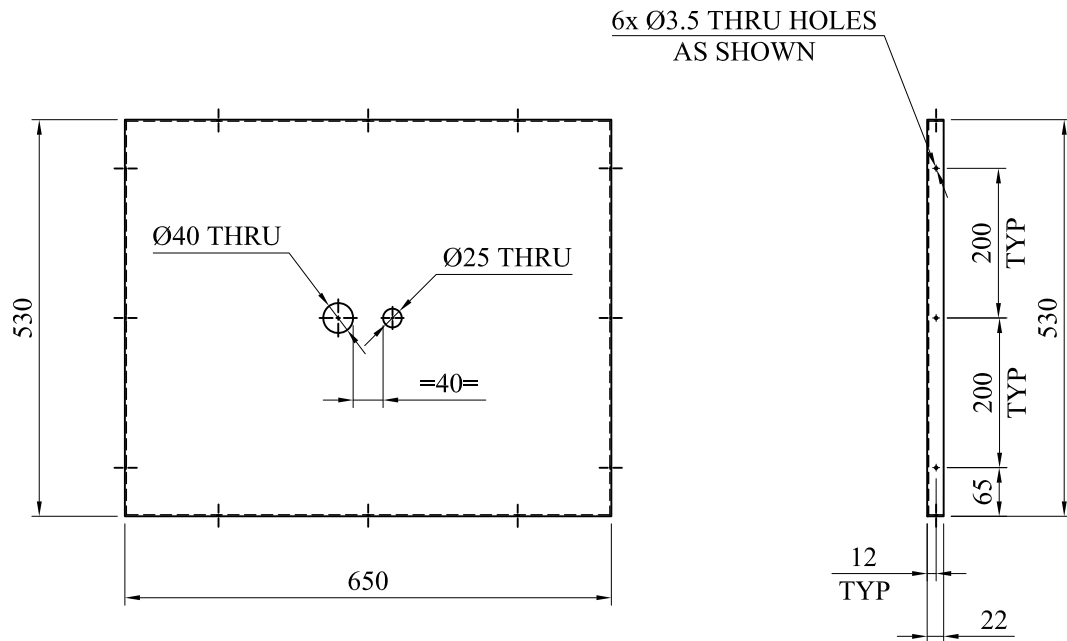
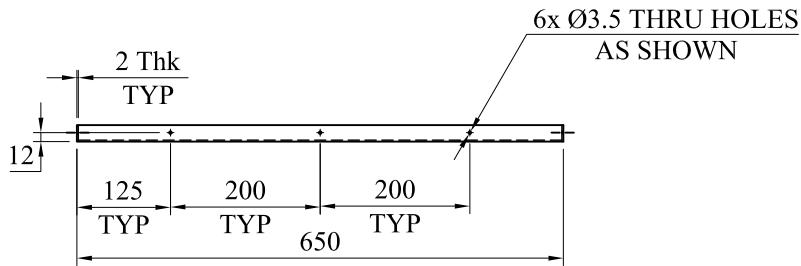
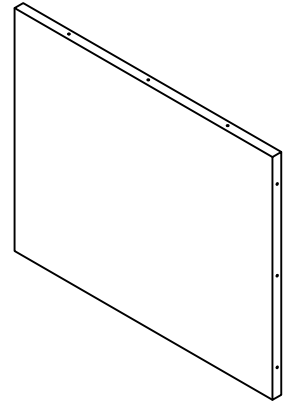

				MATERIAL : MS		
NO.	LOC.	DESCRIPTION		Auto-CAD FILE NO. ..		
REVISIONS				DRN. / DATE	APP'D./DATE	CODE NO.: ..
PROJECT OR SECTION :		TITLE			APP'D. YVC	
SEM		BACK COVER			SCALE:- 1:10	
DR'N. YADAV JS	DATE 20/03/2020				PROJECTION: THIRD ANGLE	
DRG. CHK'D. NKY	DATE ..	GOVERNMENT OF INDIA BHABHA ATOMIC RESEARCH CENTRE SECURITY ELECTRONICS & SOFTWARE SYSTEM DIVISION			DRG. NO.	REV.
DES'D. ..	DES'D. CHK'D. ..				E- 107 (2)	0

THIS DESIGN AND DRAWING IS THE PROPERTY OF BHABHA ATOMIC RESEARCH CENTRE
IT MUST BE RETURNED WITH QUOTATION OR UPON DELIVERY OF MATERIAL AND
EQUIPMENT MUST NOT BE USED EXCEPT BY PERMISSION OF THE OWNER.

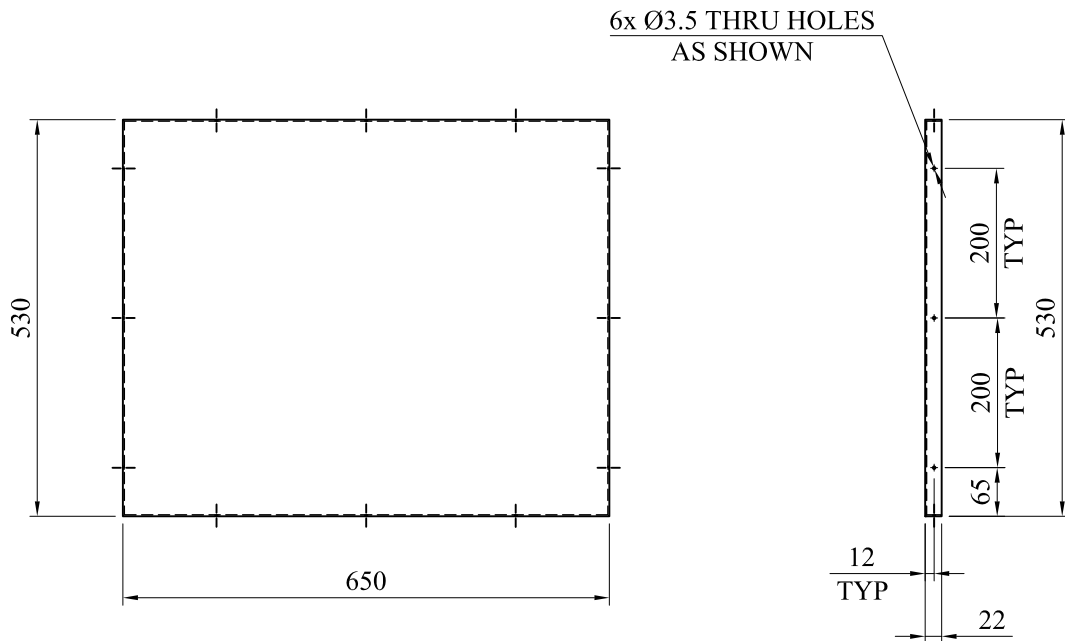
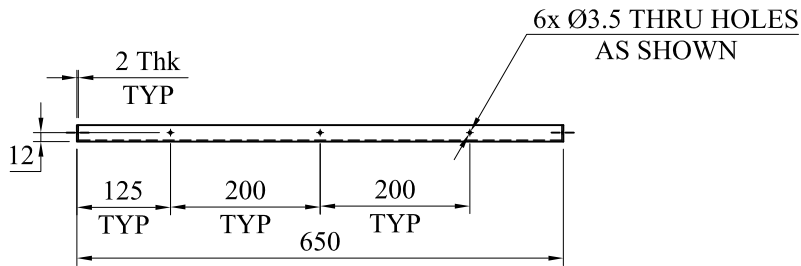
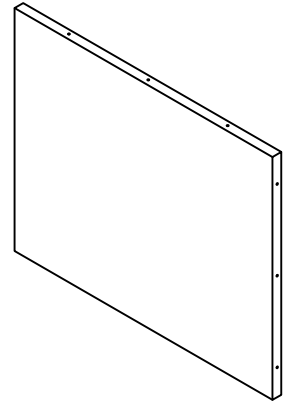

				MATERIAL : MS		
NO.	LOC.	DESCRIPTION		Auto-CAD FILE NO. ..		
REVISIONS				DRN. / DATE	APP'D./DATE	CODE NO.: ..
PROJECT OR SECTION :		TITLE			APP'D. YVC	
SEM		SIDE COVER			SCALE:- 1:10	
DR'N. YADAV JS	DATE 20/03/2020				PROJECTION: THIRD ANGLE	
DRG. CHK'D. NKY	DATE ..	GOVERNMENT OF INDIA BHABHA ATOMIC RESEARCH CENTRE SECURITY ELECTRONICS & SOFTWARE SYSTEM DIVISION			DRG. NO.	REV.
DES'D. ..	DES'D. CHK'D. ..				E- 107	0

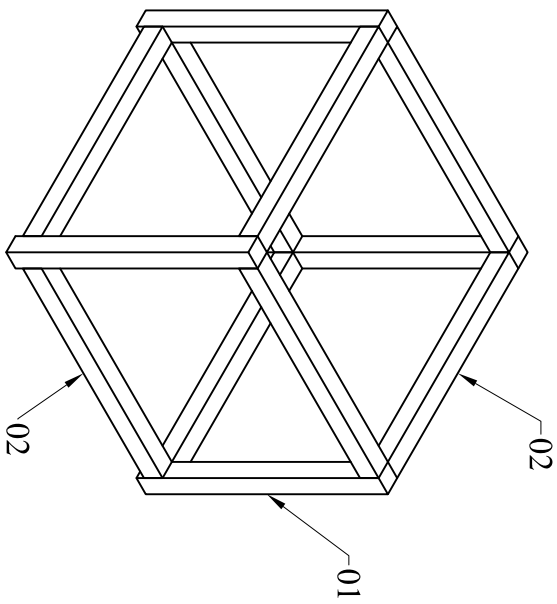
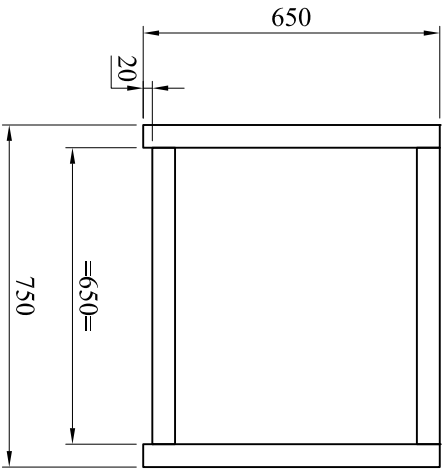
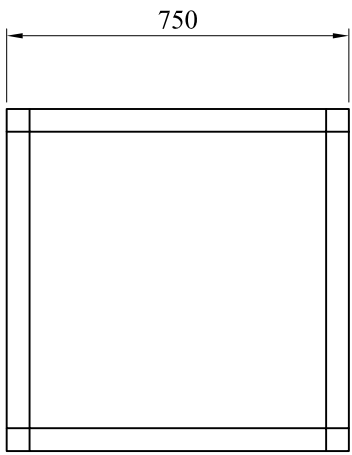

BILL OF MATERIAL						
ITEM NO.	PART NO.	DESCRIPTION	MATL.	QTY.	DRG. NO.	REMARKS
01	121	LEG	SS	04	THIS.DWG	..
02	122	LEG_SUPPORT	SS	08	THIS.DWG	..

NOTE-
SUITABLE WELDING TO BE DONE TO GET MAXIMUM STRENGTH AT ALL PLACES.
ALL WELDING SURFACES SHOULD BE FLUSHED.
PERPENDICULARITY OF 0.02mm TO BE MAINTAINED AT ALL PLACES.
IF ANY DOUBT, ASK.

LEG
PART NO. - 121

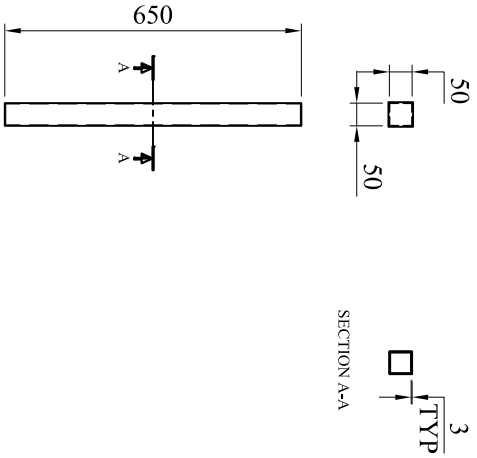

LEG SUPPORT
PART NO. - 122

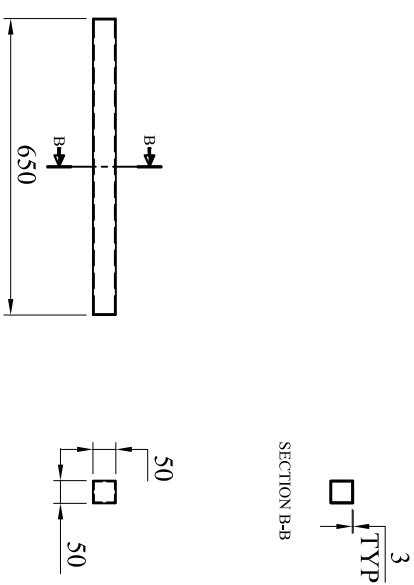

GENERAL TOLERANCE UNLESS OTHERWISE SPECIFIED

LINEAR DIMENSIONS	LENGTH OF SHORTER SIDE OF ANGLE
UPTO - 6 ± 0.1	1 - 6 ± 1°
6 - 30 ± 0.2	6 - 30 ± 0.30°
30 - 120 ± 0.3	120 - 315 ± 0.5
120 - 315 ± 0.5	315 - 1000 ± 0.8

SURFACE FINISH
IN MICRONS 3.15 CLA
CHAMFER 1 x 45°

NO.	LOC.	DESCRIPTION	DRN.	DATE	APP'D
REVISIONS					

PROJECT OR SECTION :

SEM TABLE
SESSD

DRN./DATE YADAVIS

DRG. CHK'D.

DESD.

TITLE

TABLE FRAME

GOVERNMENT OF INDIA
BHABHA ATOMIC RESEARCH CENTRE
CENTRE FOR DESIGN & MANUFACTURE

MATERIAL- MS

SHEET NO 1 OF 1 SHEETS

SCALE:- 1:20

PROJECTION: THIRD ANGLE

DRG. NO.

D-120

REV. 0

THIS DESIGN AND DRAWING IS THE PROPERTY OF BHABHA ATOMIC RESEARCH CENTRE
IT MUST BE RETURNED WITH QUOTATION OR UPON DELIVERY OF MATERIAL AND
EQUIPMENT MUST NOT BE USED EXCEPT BY PERMISSION OF THE OWNER.

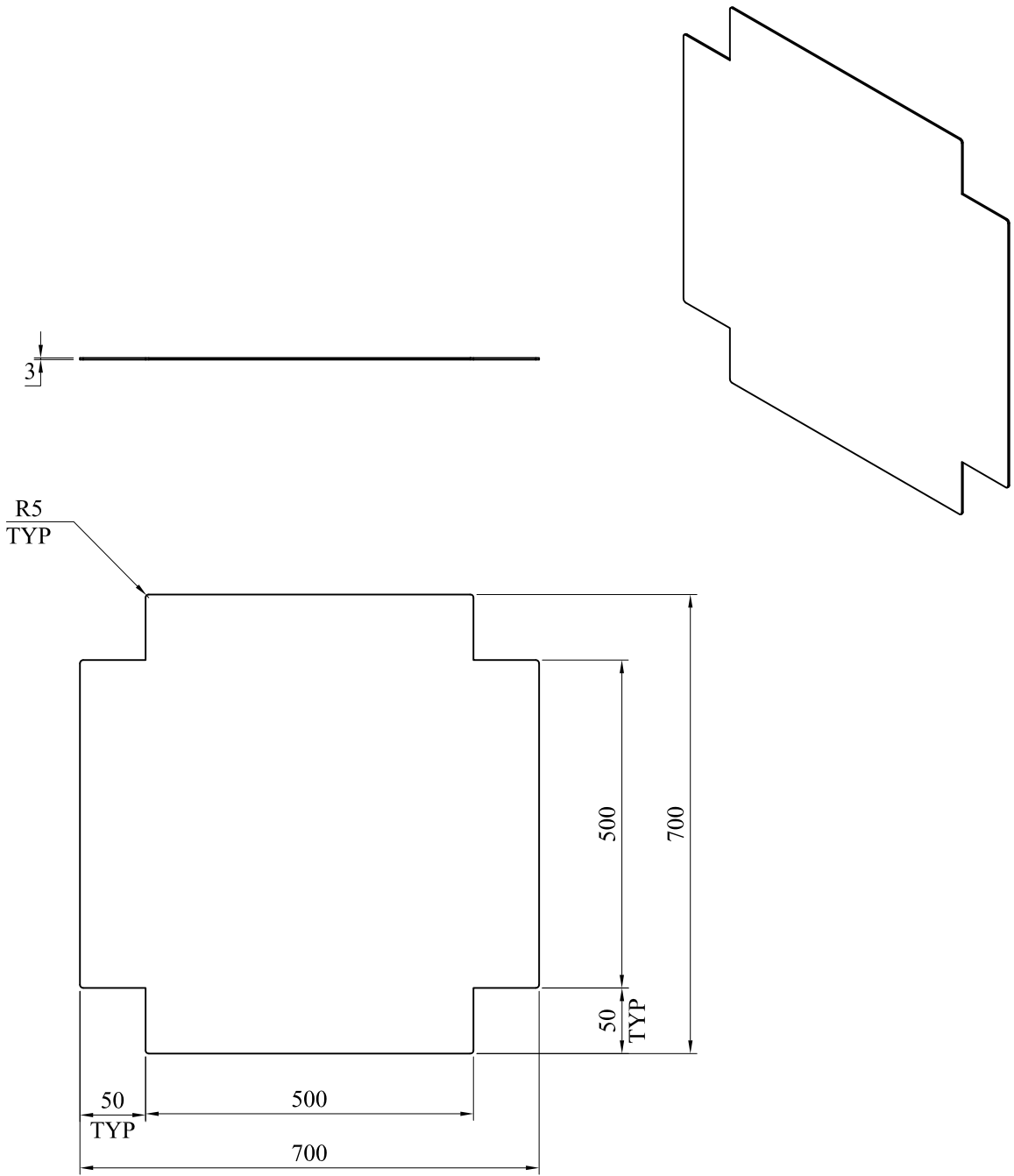

					MATERIAL : MS
NO.	LOC.	DESCRIPTION			Auto-CAD FILE NO. ..
REVISIONS			DRN. / DATE	APP'D./DATE	CODE NO.: ..
PROJECT OR SECTION :		TITLE		APP'D. yvch	
SEM TABLE		BOTTOM PLATE		SCALE:- 1:10	
DR'N. yadavjs	DATE ..	GOVERNMENT OF INDIA BHABHA ATOMIC RESEARCH CENTRE SECURITY ELECTRONICS & SOFTWARE SYSTEM DIVISION		PROJECTION: THIRD ANGLE	
DRG. CHK'D. nkyadav	DATE ..			DRG. NO.	REV.
DES'D. ..	DES'D. CHK'D. ..			E- 109	0

THIS DESIGN AND DRAWING IS THE PROPERTY OF BHABHA ATOMIC RESEARCH CENTRE
IT MUST BE RETURNED WITH QUOTATION OR UPON DELIVERY OF MATERIAL AND
EQUIPMENT MUST NOT BE USED EXCEPT BY PERMISSION OF THE OWNER.

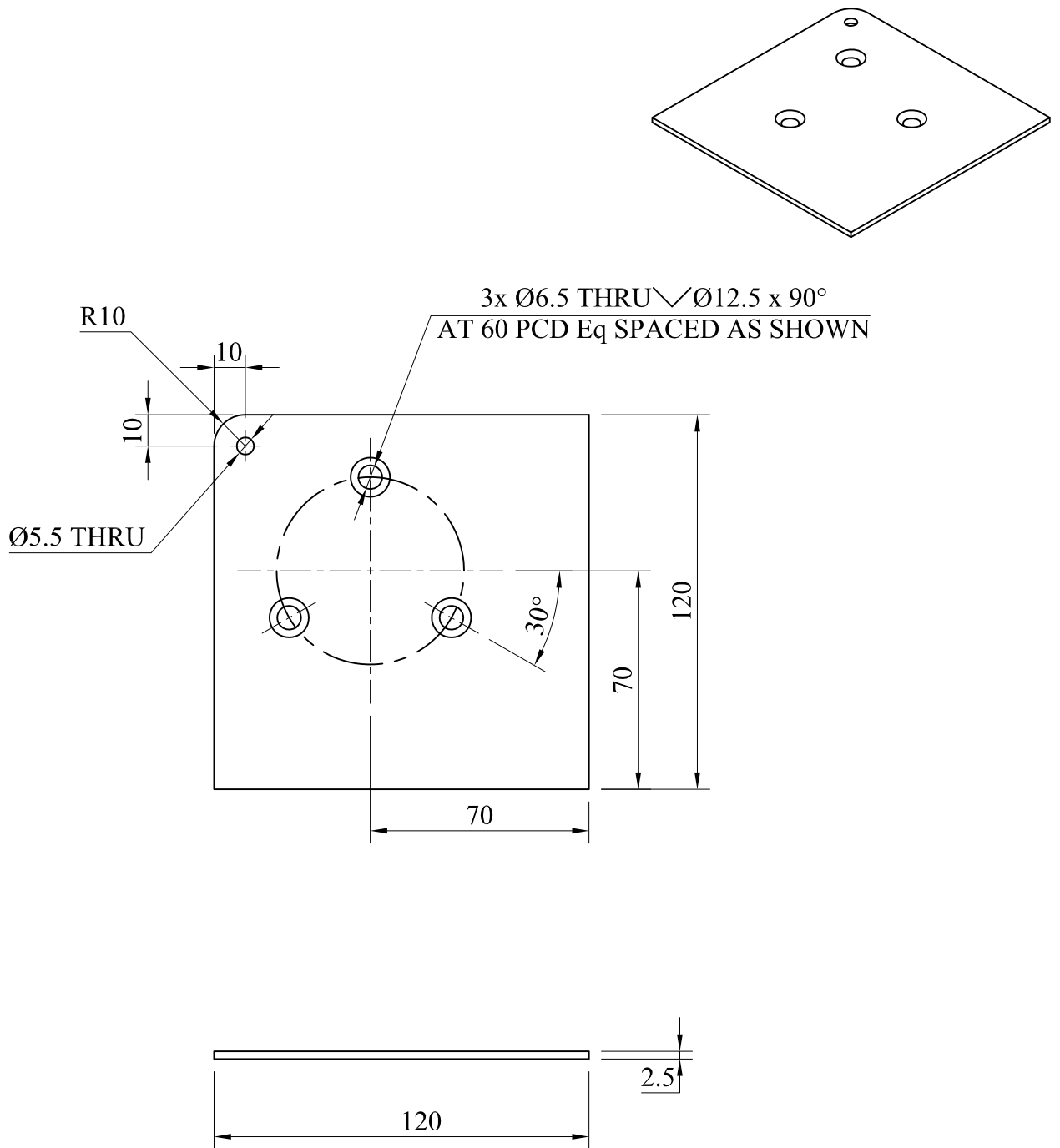

					MATERIAL : ..
NO.	LOC.	DESCRIPTION			Auto-CAD FILE NO. ..
REVISIONS			DRN. / DATE	APP'D./DATE	CODE NO. : ..
PROJECT OR SECTION :		TITLE		APP'D. ..	
SEM		BRACKET		SCALE:- 1:2	
DR'N...	DATE ..			PROJECTION: THIRD ANGLE	
DRG. CHK'D. ..	DATE ..	GOVERNMENT OF INDIA		DRG. NO-	REV.
DES'D. ..	DES'D. CHK'D. ..	BHABHA ATOMIC RESEARCH CENTRE		E - 153	0
		SECURITY ELECTRONICS & SOFTWARE SYSTEM DIVISION			

THIS DESIGN AND DRAWING IS THE PROPERTY OF BHABHA ATOMIC RESEARCH CENTRE
IT MUST BE RETURNED WITH QUOTATION OR UPON DELIVERY OF MATERIAL AND
EQUIPMENT MUST NOT BE USED EXCEPT BY PERMISSION OF THE OWNER.

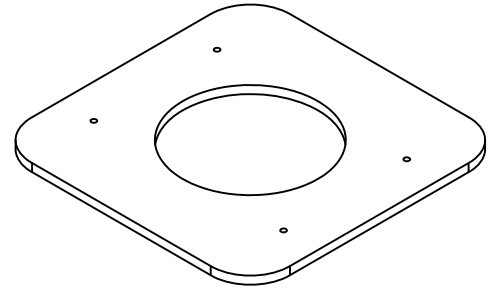

4x M6 THRU TAP
AT 285 PCD AS SHOWN

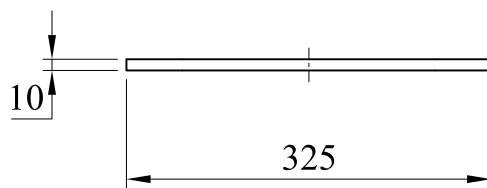
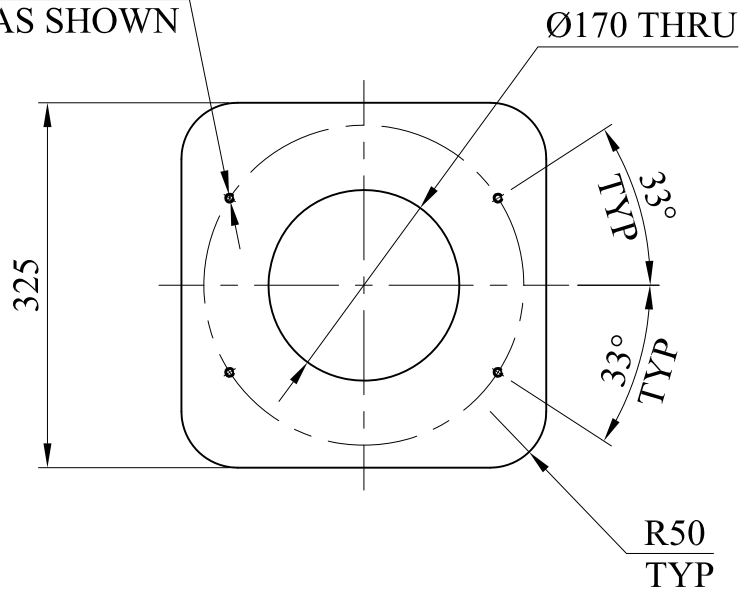

					MATERIAL : MS
NO.	LOC.	DESCRIPTION			Auto-CAD FILE NO. ..
REVISIONS			DRN. / DATE	APP'D./DATE	CODE NO. : ..
PROJECT OR SECTION :		TITLE		APP'D. yvch	
SEM		CHAMBER BASE PLATE		SCALE:- 1:10	
DR'N. yadavjs	DATE ..			PROJECTION: THIRD ANGLE	
DRG. CHK'D. nkyadav	DATE ..	GOVERNMENT OF INDIA BHABHA ATOMIC RESEARCH CENTRE SECURITY ELECTRONICS & SOFTWARE SYSTEM DIVISION		DRG. NO-	REV.
DES'D. ..	DES'D. CHK'D. ..			E- 152	0

THIS DESIGN AND DRAWING IS THE PROPERTY OF BHABHA ATOMIC RESEARCH CENTRE
IT MUST BE RETURNED WITH QUOTATION OR UPON DELIVERY OF MATERIAL AND
EQUIPMENT MUST NOT BE USED EXCEPT BY PERMISSION OF THE OWNER.

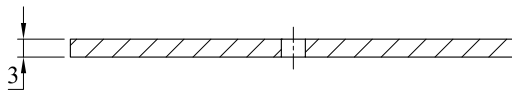
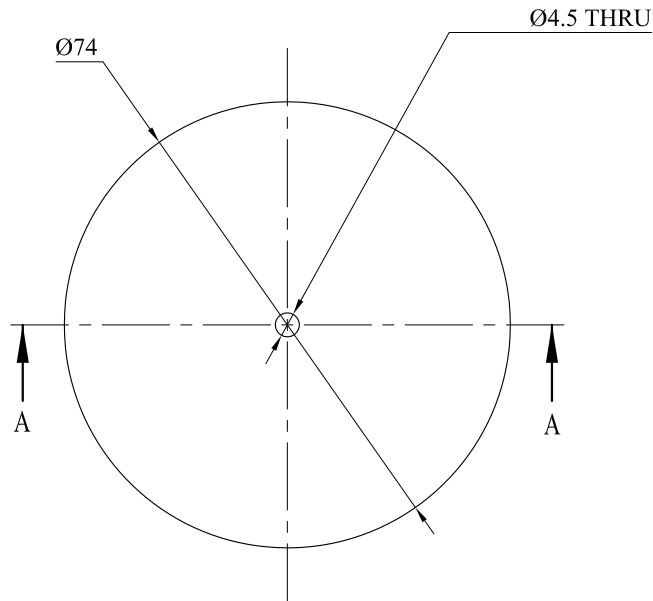
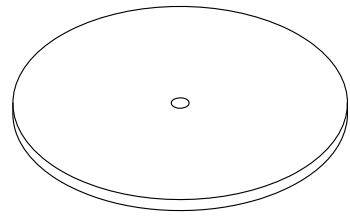

SECTION A-A

				MATERIAL.:	
NO.	LOC.	DESCRIPTION		Auto-CAD FILE NO. ..	
REVISIONS				DRN. / DATE	APP'D./DATE
PROJECT OR SECTION : SEM				TITLE DISC FOR SPRING	
DR'N. yadavjs	DATE ..			APP'D. yvch	
DRG. CHK'D. nkyadav	DATE ..			SCALE:- 1:1	
DES'D. ..	DES'D. CHK'D. ..			PROJECTION: THIRD ANGLE	
GOVERNMENT OF INDIA BHABHA ATOMIC RESEARCH CENTRE SECURITY ELECTRONICS & SOFTWARE SYSTEM DIVISION				DRG. NO-	REV.
				E - 155	02

THIS DESIGN AND DRAWING IS THE PROPERTY OF BHABHA ATOMIC RESEARCH CENTRE
IT MUST BE RETURNED WITH QUOTATION OR UPON DELIVERY OF MATERIAL AND
EQUIPMENT MUST NOT BE USED EXCEPT BY PERMISSION OF THE OWNER.

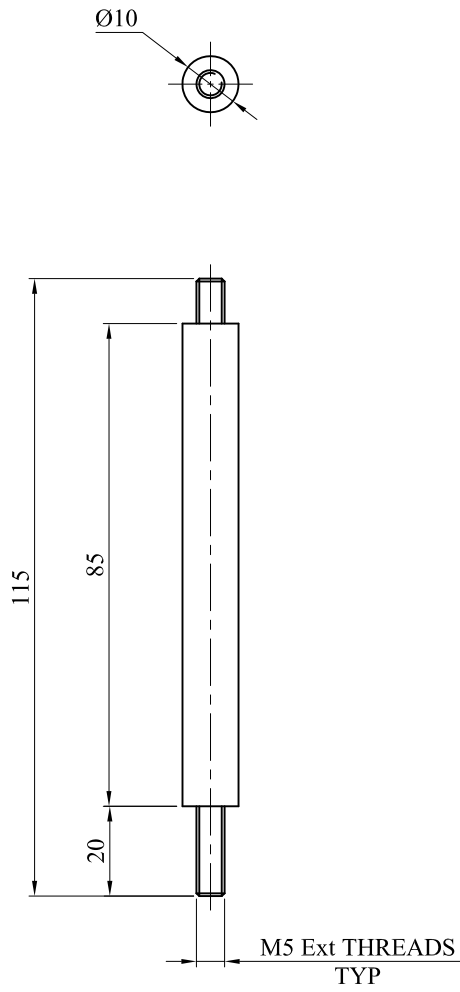

				MATERIAL : SS 304	
NO.	LOC.	DESCRIPTION			Auto-CAD FILE NO. ..
REVISIONS				DRN. / DATE	APP'D./DATE
PROJECT OR SECTION : SEM				TITLE SPRING FRAME STUD	
DR'N. YADAV JS	DATE	18/03/2020		APP'D. YVC	
DRG. CHK'D. NKY	DATE	..		SCALE:- 1:1	
DES'D. ..	DES'D. CHK'D.	..		PROJECTION: THIRD ANGLE	
GOVERNMENT OF INDIA BHABHA ATOMIC RESEARCH CENTRE SECURITY ELECTRONICS & SOFTWARE SYSTEM DIVISION				DRG. NO. E- 104	REV. 0

THIS DESIGN AND DRAWING IS THE PROPERTY OF BHABHA ATOMIC RESEARCH CENTRE
IT MUST BE RETURNED WITH QUOTATION OR UPON DELIVERY OF MATERIAL AND
EQUIPMENT MUST NOT BE USED EXCEPT BY PERMISSION OF THE OWNER.

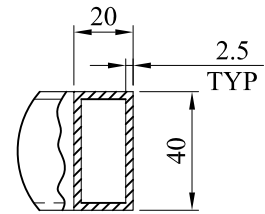
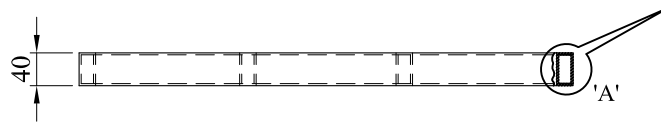
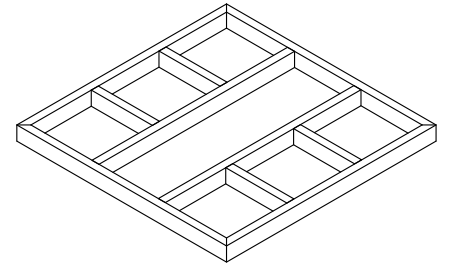
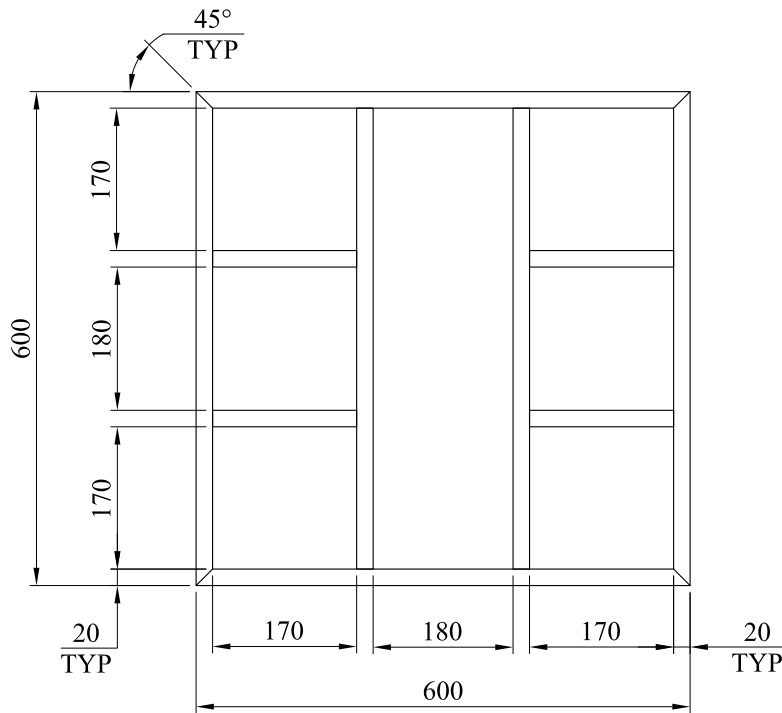

DETAIL 'A'
RATIO 4:1

NOTE

SUITABLE WELDING TO BE DONE AT ALL JOINTS TO GET MAXIMUM STRENGTH.
ALL WELDING SURFACES SHOULD BE FLUSHED.
PERPENDICULARITY OF 0.02mm TO BE MAINTAINED AT ALL PLACES.
IF ANY DOUBT, ASK.

					MATERIAL : MS	
NO.	LOC.	DESCRIPTION			Auto-CAD FILE NO. ..	
REVISIONS			DRN. / DATE	APP'D./DATE	CODE NO. : ..	
PROJECT OR SECTION :		TITLE			APP'D. yvch	
SEM		SPRING FRAME			SCALE:- 1:10	
DR'N. yadavjs	DATE ..	GOVERNMENT OF INDIA BHABHA ATOMIC RESEARCH CENTRE SECURITY ELECTRONICS & SOFTWARE SYSTEM DIVISION			PROJECTION: THIRD ANGLE	
DRG. CHK'D. nkyadav	DATE ..				DRG. NO-	REV.
DES'D. ..	DES'D. CHK'D. ..				E - 151	0

THIS DESIGN AND DRAWING IS THE PROPERTY OF BHABHA ATOMIC RESEARCH CENTRE
IT MUST BE RETURNED WITH QUOTATION OR UPON DELIVERY OF MATERIAL AND
EQUIPMENT MUST NOT BE USED EXCEPT BY PERMISSION OF THE OWNER.

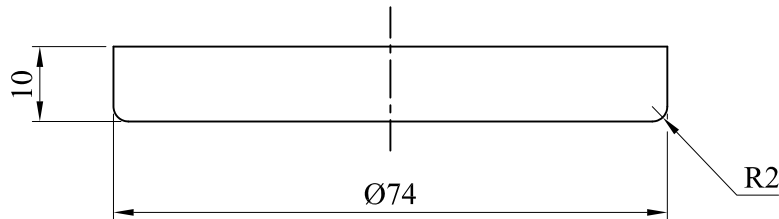
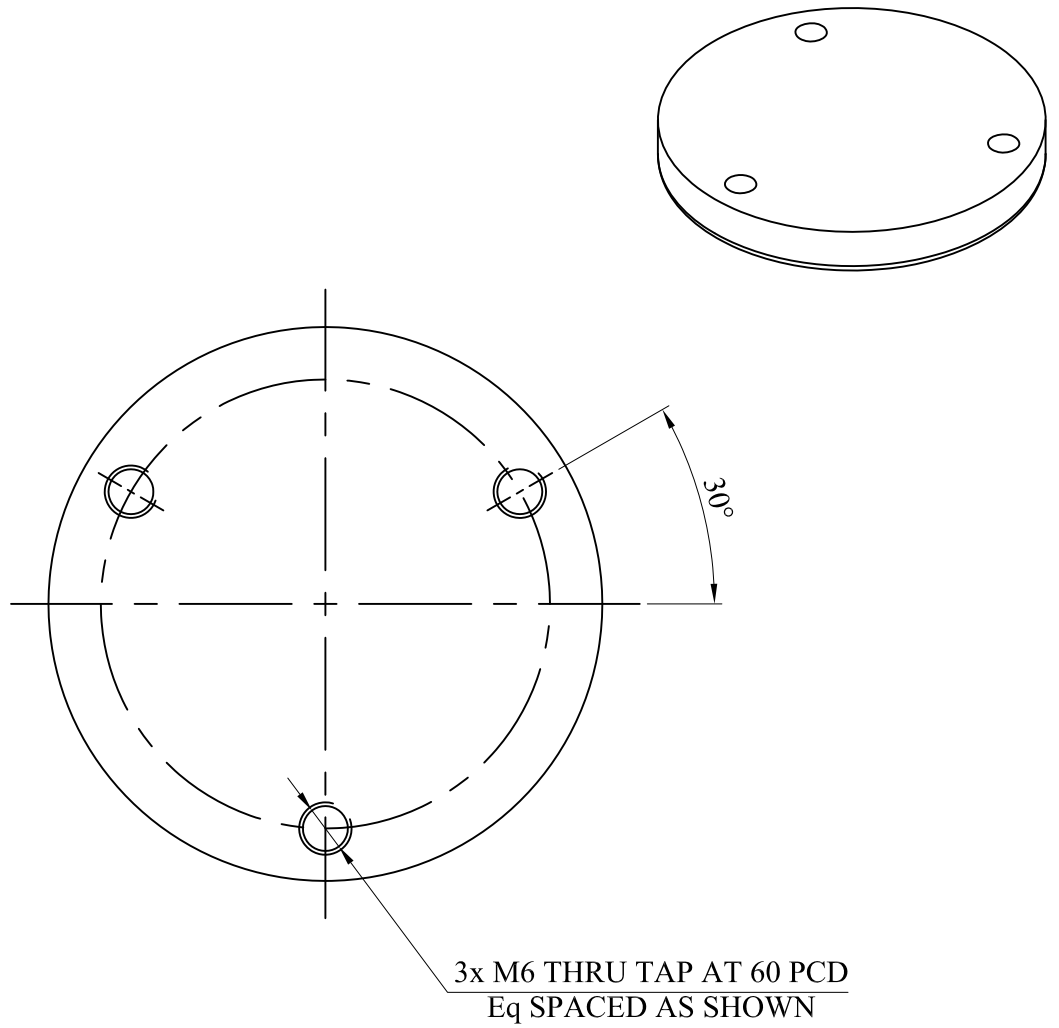

				MATERIAL : MS	
NO.	LOC.	DESCRIPTION		Auto-CAD FILE NO. ..	
REVISIONS				DRN. / DATE	APP'D./DATE
PROJECT OR SECTION : SEM				TITLE UPPER SPRING DISC	
DR'N. yadavjs	DATE ..			APP'D. yvch	
DRG. CHK'D. nkyadav	DATE ..			SCALE:- 1:1	
DES'D. ..	DES'D. CHK'D. ..			PROJECTION: THIRD ANGLE	
GOVERNMENT OF INDIA BHABHA ATOMIC RESEARCH CENTRE SECURITY ELECTRONICS & SOFTWARE SYSTEM DIVISION				DRG. NO- E - 157	REV. 0

THIS DESIGN AND DRAWING IS THE PROPERTY OF BHABHA ATOMIC RESEARCH CENTRE
IT MUST BE RETURNED WITH QUOTATION OR UPON DELIVERY OF MATERIAL AND
EQUIPMENT MUST NOT BE USED EXCEPT BY PERMISSION OF THE OWNER.

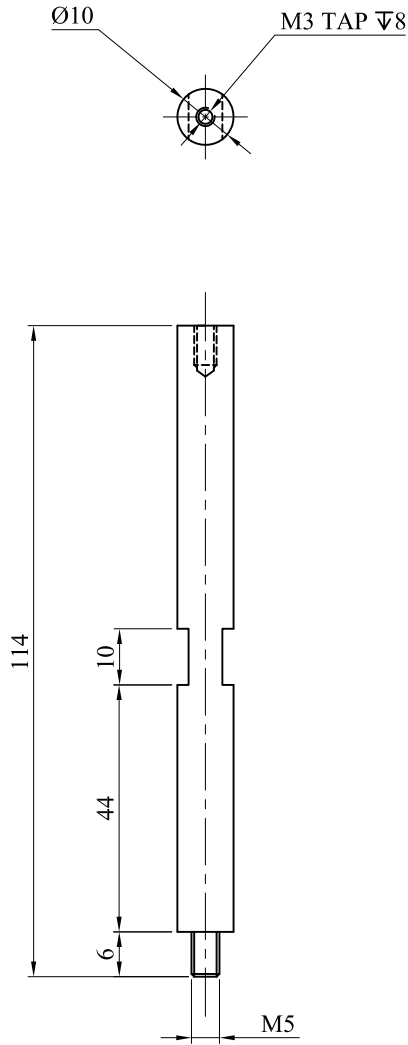

				MATERIAL : SS 304	
NO.	LOC.	DESCRIPTION			Auto-CAD FILE NO. ..
REVISIONS				DRN. / DATE	APP'D./DATE
PROJECT OR SECTION :		TITLE			CODE NO.: ..
SEM		TOP PLATE SUPPORT STUD			APP'D. YVC
DR'N. YADAV JS	DATE 18/03/2020				SCALE:- 1:1
DRG. CHK'D. NKY	DATE ..				PROJECTION: THIRD ANGLE
DES'D. ..	DES'D. CHK'D. ..	GOVERNMENT OF INDIA BHABHA ATOMIC RESEARCH CENTRE SECURITY ELECTRONICS & SOFTWARE SYSTEM DIVISION			DRG. NO. E- 105
					REV. 0

THIS DESIGN AND DRAWING IS THE PROPERTY OF BHABHA ATOMIC RESEARCH CENTRE
IT MUST BE RETURNED WITH QUOTATION OR UPON DELIVERY OF MATERIAL AND
EQUIPMENT MUST NOT BE USED EXCEPT BY PERMISSION OF THE OWNER.

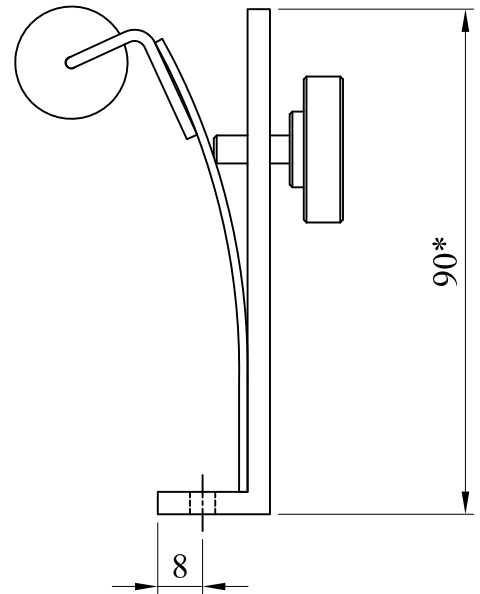
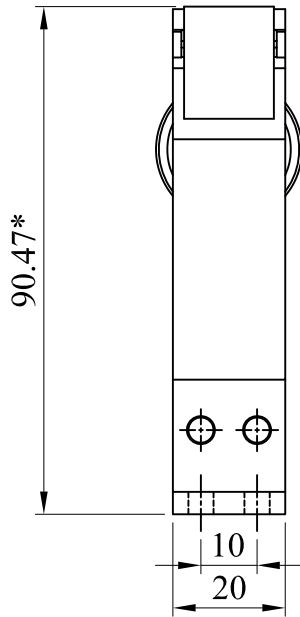
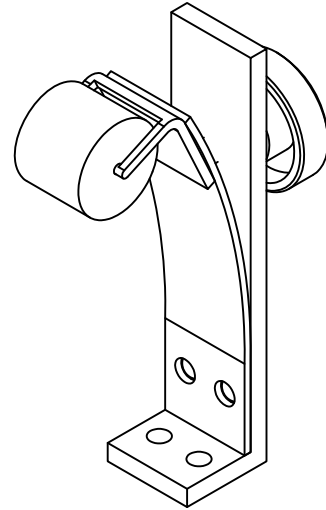
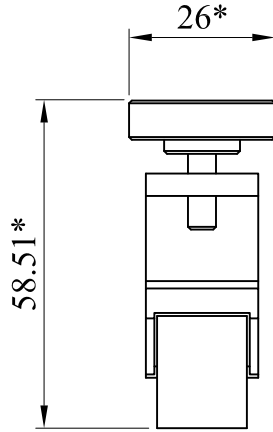

* MAXIMUM SPACE AVAILABLE FOR LEAF SPRING ASSEMBLY.
FINAL DIMENSIONS AND DESIGN IS UP TO YOU AS INFORMED,
SHOULD BE COMPATIBLE IN TABLE.
IF ANY DOUBT, ASK.

					MATERIAL :..
NO.	LOC.	DESCRIPTION			Auto-CAD FILE NO. ..
REVISIONS			DRN. / DATE	APP'D./DATE	CODE NO.: ..
PROJECT OR SECTION :		TITLE		APP'D. yvch	
..		LEAF SPRING ASSM		SCALE:- 2:3	
DR'N. yadavjs	DATE ..			PROJECTION: THIRD ANGLE	
DRG. CHK'D. nkyadav	DATE ..	GOVERNMENT OF INDIA		DRG. NO.	REV.
DES'D. ..	DES'D. CHK'D. ..	BHABHA ATOMIC RESEARCH CENTRE		E- 200	0
		SECURITY ELECTRONICS & SOFTWARE SYSTEM DIVISION			